



Agenda
for
52nd PCC meeting

Date: 16.02.2017
Eastern Regional Power Committee
14, Golf Club Road, Tollygunge
Kolkata: 700 033

EASTERN REGIONAL POWER COMMITTEE

AGENDA FOR 52ND PROTECTION SUB-COMMITTEE MEETING TO BE HELD AT ERPC, KOLKATA ON 16.02.2017 (THURSDAY) AT 11:00 HOURS

PART – A

ITEM NO. A.1: Confirmation of minutes of 51st Protection sub-Committee Meeting held on 16th January, 2017 at ERPC, Kolkata.

The minutes of 51st Protection Sub-Committee meeting held on 16.01.17 circulated vide letter dated 23.01.17.

Members may confirm the minutes of 51st PCC meeting.

PART – B

ANALYSIS & DISCUSSION ON GRID INCIDENCES OCCURRED IN JANUARY, 2017

ITEM NO. B.1: Disturbance at 220 kV Kalyaneswari (DVC) S/s on 10-01-17 at 22:05 hrs.

1. **Single line diagram: Not Submitted**

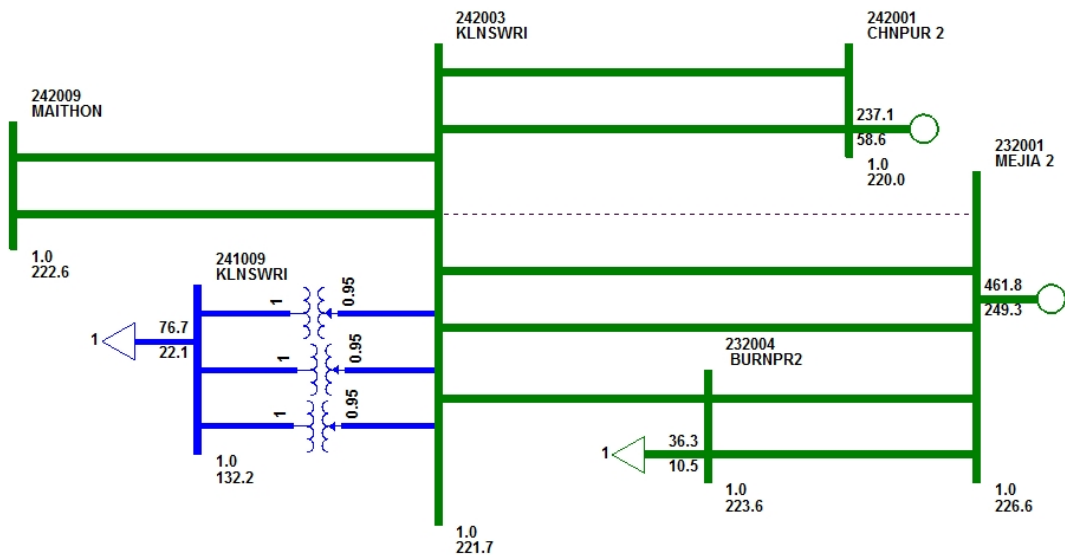

2. **Pre fault conditions: Submitted**

220kV Bus arrangement

Main Bus # 1: L # 202, L # 229, L # 238, L # 240, ATR # 1

Main Bus # 2: L # 201, L # 228, L # 237, L # 239, ATR # 3

SI No	Name of the line	Pre Fault Load (MVA)
1	ATR#1	101
2	ATR#2	100

3	ATR#3	90
4	L#240 / 239	64
5	L#228	86
6	L#201 / 202	34
7	L#237 / 238	78
8	L # 229	8

3. Detailed analysis of tripping incident: Submitted

At 22:00 hrs, low Air pressure SF₆ gas occurred in Mejia - I (L#239) bay at Kalyaneswari s/s. Both the trip coil of Mejia - I (L#239) bay became in-operative to safe guard the breaker from any further trip/close operation. After 5 min, distance protection relay of Mejia - I (L#239) bay operated resulting tripping of all 220 kV lines except Burnpur (L#229) and ATRs. The reason for non-tripping of Burnpur (L#229) and ATRs is due to non-operation of the VAJC relay operation.

4. Disturbance record: Submitted

5. Remedial action taken : submitted

Operators have been instructed to visually inspect operation of VAJC flag and contacts after each Isolator related operations viz. Bus Changeover / Diversion etc.

Analysis of PMU plots:

- No fault has been detected by PMU.
- 3 kV voltage dip in R phase has been observed in Durgapur PMU data at 22:08 hrs.

Status of Reporting: Tripping report received from DVC on 30-01-17.

DVC may explain.

ITEM NO. B.2: Disturbance at 220kV NJP (WBSETCL) S/s on 19-01-17 at 00:12 Hrs.

1. Single line diagram: Not Submitted

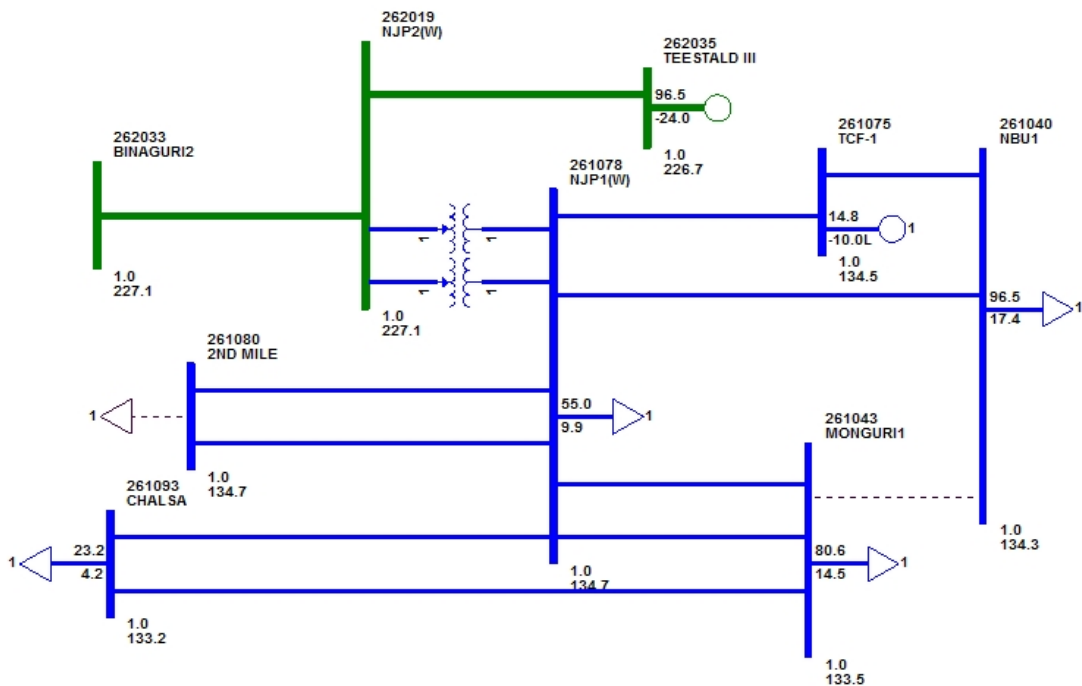

2. Pre fault conditions: Submitted

- a. Bus I: 220/132 kV ATR I, 220 kV TLDP – III, 220 kV TLDP – IV – I
- b. Bus II: 220/132 kV ATR II & III at NJP, 220 kV TLDP – IV – II
- c. B/C was in closed condition

3. Detailed analysis of tripping incident: Submitted

At 00:12 hrs, 132 kV NJP(WB) – NJP(PG) S/C tripped from both end due to R phase CVT burst at WB end. At the same time, 132 kV NJP (WB) – Chalsa S/C tripped from both end on B-N fault and 220 kV bus-extension breaker at Binaguri S/S tripped on RXMVB4 protection. During this incident under frequency relay operated at NJP (WB) S/S and 33 kV Dabgram, Radhabari and Raninagar feeders and 33/11 kV ATR – I & II at NJP (WB) tripped resulting power failure in 33 kV network. At 00:14 hrs, 132 kV NJP(WB) – NBU tripped from NJP end on E/F and High set protection resulting total power failure at NJP (WB) s/s.

As per relay indication provided by WBSETCL, fault clearing time of 132 kV NJP(WB) – NJP(PG) S/C was 627 ms.

During restoration, power was extended from 132 kV Siliguri S/S via 132 kV NJP – Siliguri (2 Mile) S/S. After charging 220 kV bus – I & II through 220/132 kV ATR – I, II & III, voltage became very high and all the transformers tripped on over flux protection.

The relay indications are as follows:

Time	Name of the element	Relay at NJP (WB) end	Relay at remote end
00:12 hrs	132 kV NJP (PG) feeder	R-N, Z-I, 0.6 km, 627.7 ms	R-Y, Z-I, O/C, 10.2 km
	132 kV Chalsa feeder	B-N, Z-I, 27.7 km, 88.3 ms	R-Y, Z-I, O/C, 10.2 km
	220 kV bus extension I & II	No relay was picked up	RXMVB4 types relay
	33 kV Transfer B/C, 33 kV Dabgram, Radhabari and Raninagar feeder and 33/11 kV ATR – I & II at NJP (WB)	Tripped due to under frequency relay operation	
	132 kV NBU feeder	E/F, High set, 163.2 ms	Did not trip
	220 kV TLDP – III, 220 kV TLDP – IV – I & II, 220/132 kV ATR I, II & III, 220 kV B/C, 132/33 kV ATR – I & II, 132 kV TCF – I, 132 KV Siliguri (2 Mile) – I & II	Did not trip from any end	
00:34 hrs	220/132 kV ATR I, II & III	Over-flux	

4. Disturbance record: Submitted the details

5. Remedial action taken : Not submitted

Status of Reporting: Tripping report received from WBSETCL on 27-01-17

WBSETCL and Powergrid may explain the following:

- Tripping of 132 kV NJP(WB) – NBU S/C at NJP(WB) on high set and E/F may be explained by WBSETCL.
- Tripping of bus extension breaker at NJP may be explained by POWERGRID.
- Reason of under-frequency relay operation may be explained.
- WB SLDC may submit the amount of energy un-served due to this incident.

ITEM NO. B.3: Total power failure at Hatia-Ranchi-Namkom-PTPS complex of JUSNL system on 25-01-17 at 08:45hrs.

1. Single line diagram: Submitted

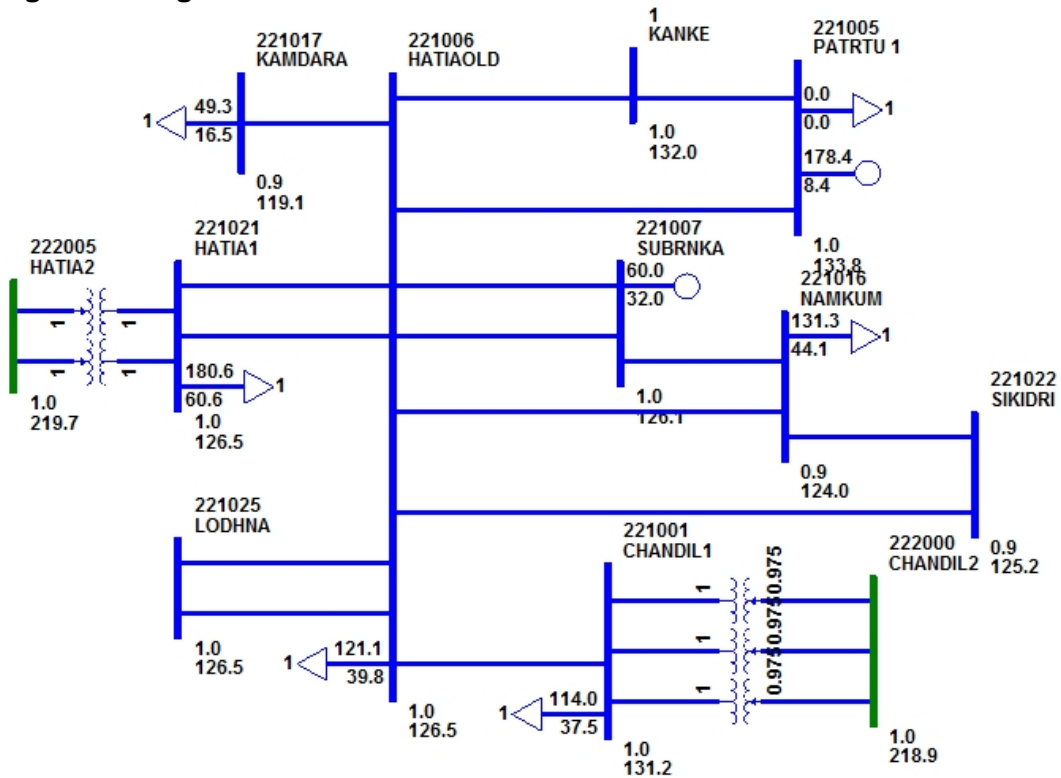

2. Pre fault conditions: Not Submitted

3. Detailed analysis of tripping incident: Submitted

At 08:45hrs, total power failure occurred at Hatia-Ranchi-Namkom-PTPS complex of JUSNL. A transient fault occurs somewhere in 132KV Kanke –Hatia line-I. Relay at 132KV Hatia I end failed to clear the fault. 132KV Hatia old-Hatia line I tripped from both ends but other link line did not trip on either end (i.e. electromechanical relay both end). As a result all the three 150MVA auto Transformer at 220kV Hatia tripped from both ends with tripping of 132KV Hatia II – Namkum Transmission line at remote end. Following elements tripped during the incident:

Time	Name of the element	Relay at local end	Relay at remote end
08:45 hrs	220/132 kv ICT – I, II, III at Hatia (II)	ICT- I Trip relay group A 86A1, 86A2 ICT – Trip relay group A 86A1, group B 86B2 & 86B2 ICT – III VAJ trip relay, Non directional O/C, E/F protection	
	132 kV Hatia (II) – Hatia (I) – II	Directional E/F protection, Master trip relay	Did not trip
	132 kV Hatia (II) (Sikdiri) – Hatia (I) – I	Directional E/F 30D	Did not trip
	220 kV B/C at Hatia (II)	Trip relay ICT-1 86, ICT-2 ckt. Supervision relay R phase 295R	
	132 kV Hatia (I) – PTPS 9C	Active group 1, fault duration 120 ms	Information yet to be received
	132 kV Hatia (I) – Kanke 8C	Information yet to be received	TPF
	132KV PTPS-Kanke 8C	Differential protection, Z-III, O/C start, E/F start, fault duration 1.6 sec, 64 km	TPF, fault duration= 16.67ms, relay trip time= 79.93 ms

	132KV Hatia(I)-HEC 8C	Directional E/F relay	Information yet to be received
	132 kV Hatia I – Kamdara – Gumla	Information yet to be received	

4. **Disturbance record:** Submitted

5. **Remedial action taken :** Submitted

- Thorough patrolling of 132KV Hatia I – Kanke Transmission line has been done. No abnormality / fault has not been found.
- Activation of GPS system in 132KV GSS Hatia I is in process.
- Replacement of old electromechanical relay with new micom relay will be done with in a week at both end (i.e. 132KV Hatia I & 220 KV Hatia II end).

Analysis of PMU plots:

- At 08:45 hrs, 6 kV voltage dip observed in R phase. Fault clearance time 1200 ms.

Status of Reporting: Tripping report along with DR & EL were received from JUSNL on 26-01-17.

JUSNL may explain the following:

- JUSNL may explain the reason for proper reason and sequence of this incident.
- As per PMU data, fault was being fed for more than 1200 ms. Delayed clearance of the fault resulted tripping of multiple elements in the system. Reason for delayed clearance may be explained.

ITEM NO. B.4: Disturbance at 220 kV Gaya (PG) S/s on 13-01-17 at 12:49 Hrs.

1. **Single line diagram:** Not Submitted

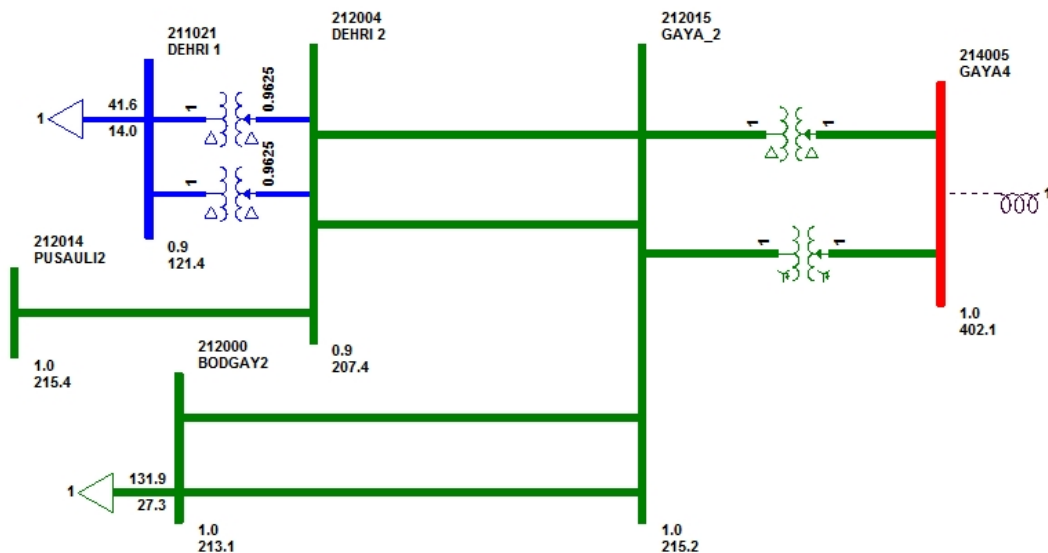

2. **Pre fault conditions:** Not Submitted

3. **Detailed analysis of tripping incident:** Submitted

At 12:49 hrs, all the feeders connected to 220 kV bus bar I at Gaya i.e. 220 kV Gaya – Dehri – I, 220 kV Gaya – Bodhgaya – I and 220 kV Gaya – Sonenagar – II tripped in bus bar operation.

4. **Disturbance record:** Submitted

5. **Remedial action taken :** Not Submitted

Analysis of PMU plots:

- At 12:49 hrs, no voltage dip has been observed in PMU data.

Status of Reporting: POWERGRID has submitted DR files on 25-01-17

Powergrid may explain the reason for bus bar operation.

ITEM NO. B.5: Disturbance at 400 kV Kahalgaon (NTPC) S/s on 11-01-17 at 12:28 Hrs.

1. **Single line diagram:** Not Submitted

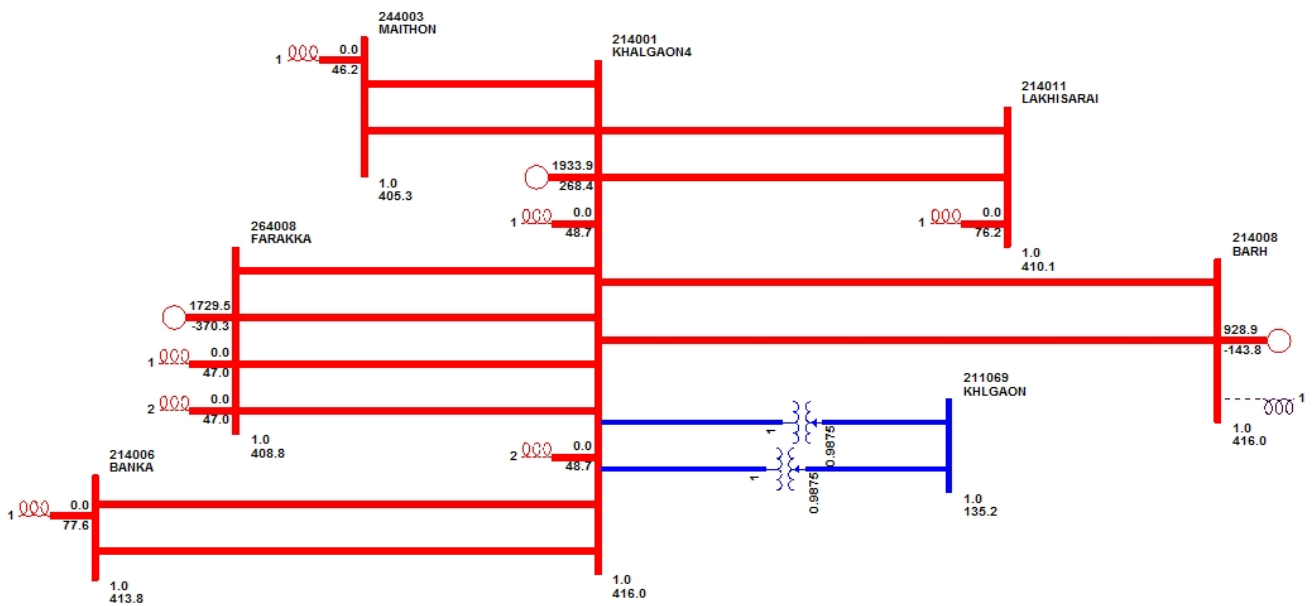

2. **Pre fault conditions:** Not Submitted

3. **Detailed analysis of tripping incident:** Submitted

At 12:28 hrs, both main & tie breaker of Lakhisrai – I feeder tripped from KhSTPP end on DT receipt from remote end. R & B phase pole of main breaker opened instantaneously. But Y phase pole did not open resulting pole discrepancy followed by opening of all breakers connected to bus – I. After 2.5 sec, Y phase pole of Lakhisrai – I feeder also tripped.

4. **Disturbance record:** Submitted

5. **Remedial action taken :** Not Submitted

Analysis of PMU plots:

- At 12:28 hrs, no voltage dip has been observed in PMU data.

Status of Reporting: NTPC Kahalgaon has submitted the tripping report on 11-01-17

NTPC and Powergrid may explain.

ITEM NO. B.6: Disturbance at 400 kV Kahalgaon (NTPC) S/s on 24-01-17 at 17:12 Hrs.

1. Single line diagram: Not Submitted

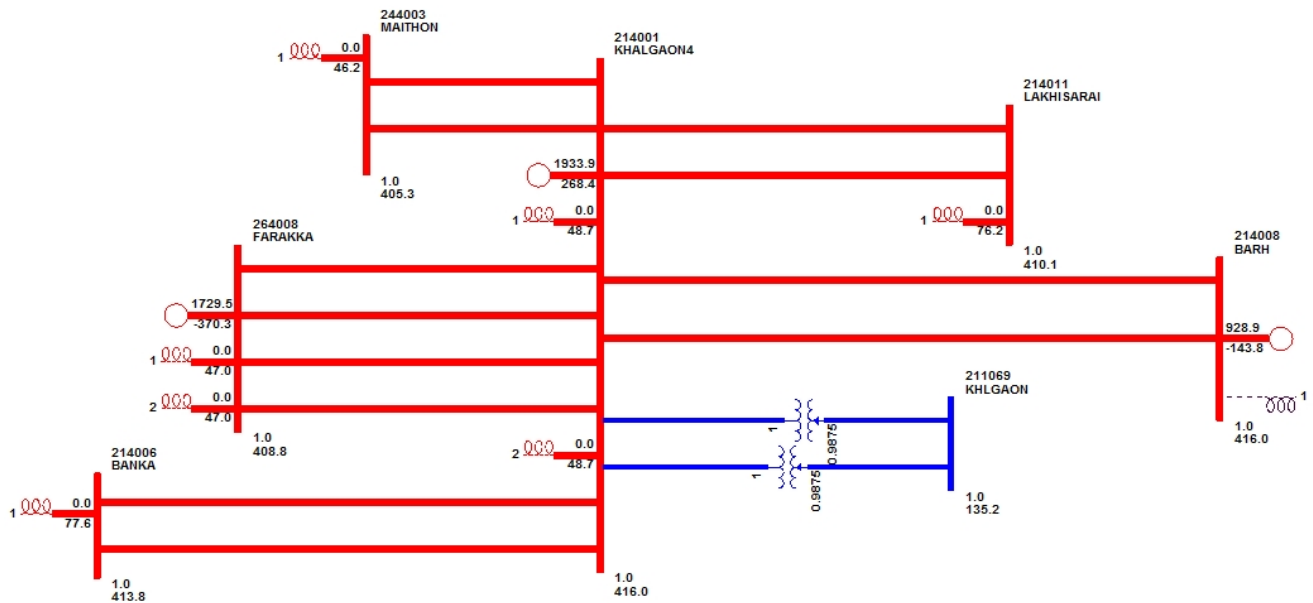

2. Pre fault conditions: Submitted

400 kV Kahalgaon – Maithon - I & II was under s/d for CT replacement work.

3. Detailed analysis of tripping incident: Submitted

At 17:12 hrs, all the breakers connected to 400 kV bus – II at Kahalgaon tripped on operation of low impedance TEED #2 relay along with BFR (breaker failure relay) operation in 400 kV Kahalgaon – Maithon – I. At the time of incident, main bay CT replacement of 400 kV Kahalgaon – Maithon - I & II was under progress. It is suspected that Induction in secondary wiring of CT might have generated significant current to trigger the TEED relay as well as BFR, during CT secondary connection of main bay CT (B phase) of Maithon – I. Since TEED & BFR relay were receiving same CT secondary input; hence BFR of 400 KV Kh-Maithon#1 main bay has also sensed similar current (i.e. more than 200 mA secondary side as per settings).

Subsequently, all the breakers connected to 400 KV BUS#II tripped after approx 200 ms time delay. Such induction has prevailed for approx. 3 to 4 seconds during this incident as per event logger records (as mentioned by NTPC).

As 400 kV Maithon – II & Kahalgaon – IV were in same bay, tie breaker of Kahalgaon – IV feeder was in off condition. Main breaker of Kahalgaon – IV feeder tripped due to BFR operation resulting tripping of Kahalgaon – IV circuit.

Due to PLCC panel problem, spurious DT signal was sent to Barh resulting tripping of 400 kV Barh – I feeder from Barh end though line was in charged condition at local end through tie breaker.

4. Disturbance record: Submitted

5. Remedial action taken : Submitted

- Inter-tripping through PLCC in 400 KV Kh- Barh#1 line will be verified during opportunity shutdown.

Analysis of PMU plots:

- At 17:12 hrs, no voltage dip has been observed in PMU data.

Status of Reporting: NTPC Kahalgaon has submitted the tripping report on 24-01-17

.NTPC and Powergrid may explain.

ITEM NO. B.7: The smelter line tripping incident at Sterlite(Vedanta) on 06-01-17 .

On 06.01.17, at 1435 hrs, three smelter lines from Sterlite(Vedanta) in Odisha tripped causing 800 MW load loss. As per PMU fault appears in R-Phase at that time and frequency rise of 0.12 Hz.

Till date ERLDC has not received any details from Vedanta and OPTCL.

Vedanta and OPTCL may place the details and explain.

PART- C:: OTHER ITEMS

FOLLOW-UP OF DECISIONS OF THE PREVIOUS PROTECTION SUB-COMMITTEE MEETING(S)

(The status on the follow up actions is to be furnished by respective constituents)

ITEM NO. C.1: Disturbance at 400 kV Meramundali (OPTCL) S/s on 13-12-16 at 12:36 Hrs.

1. Single line diagram: Submitted

220 kV feeder arrangement

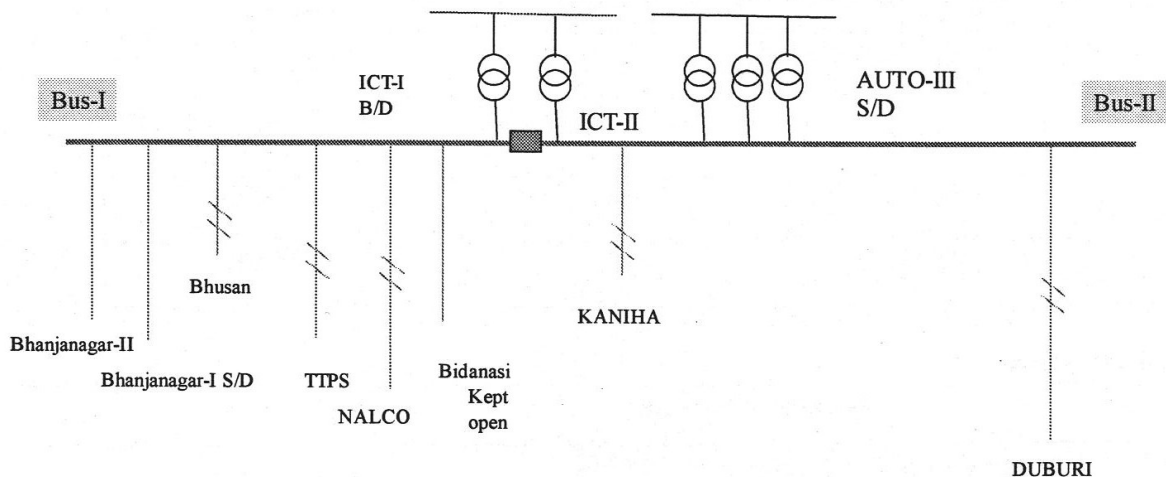

2. Pre fault conditions: Submitted

The following lines were not in service:

- a. 400kV Talcher- Meeramandali S/C
- b. 400kV Meeramandali- Mendhasal S/C
- c. 220kV TSTPS- Rengali S/C
- d. 220kV Meeramandali- Bhanjanagar-I

- e. 220 kV Meramundali – Bidansi
- f. 220/132 kV ATR – III at Meramundali
- g. 400/220kV, 315 MVA ICT-I at Meeramandali

400 kV Bus arrangement:

Bus I	Bus II	Tie-Breaker ON
Vedanta-II	Angul-I	401-ON
Mendhsal-I(Idle charged)	Duburi-II	402-OFF
Angul-II	Vedanta-I(Through Tie Bkr as Main Bkr is under S/D)	403-ON
Duburi-I	Mendhasal-II(Not in Service)	404-not in service
JSPL-I	KANIHA (S/D)	405-ON
ICT-I (B/D)	Future	406- not in service
Future-7	ICT-II	407-ON
GKEL	JSPL-II	408-ON

3. Detailed analysis of tripping incident: Submitted

Due to Y phase PT burst at 220 kV Bus II, all 220 kV feeders along with B/C tripped from Meramundali S/S. At same time 400 kV Angul – I & II, Vedanta, New Duburi - I & II and anti-theft charged portion of 400 kV Mendasal feeders tripped from Meramundali on O/V.

The relay indications are as follows:

Time (Hrs)	Name of the element	Relay at local end	Relay at remote end
12:36 hrs	220 kV TTPS I & II	Did not trip	D/P, Z-II
	220 kV Bhanjanagar – II (Ckt I under S/D)	R – B, Z – I, (-1) km from Meramundali	Did not trip
	220 kV NALCO I & II	Did not trip	D/P, Z-II
	220 kV Kaniha – I	B – N, Z – I, O/C, 2.55 km	Did not trip
	220 kV Kaniha – II	Y-N, O/C, Z- I	Did not trip
	220 kV Duburi – I & II	Did not trip	Y-B, Z-II, E/F
	400 kV Angul – I & II, Vedanta, New Duburi - I & II and anti-theft charged portion of 400 kV Mendasal feeders	O/V at Meramundali	Did not trip
	Others 400 kV feeders	Did not trip	Did not trip
	220 kV Bhusan I & II	Islanded at Bhusan end	
	220 kV B/C	Tripped on O/C	
	220/132 kV ATR I & II (ATR III under S/D)	Tripped on over-flux relay operation from 220 kV side	
	400/220 kV ICT - II	Tripped on 220 kV side on O/C	

4. **Disturbance record:** submitted

5. **Remedial action taken :** Not submitted

Analysis of PMU plots:

- At 12:36:18:800 hrs, approximately 38kV dip has been observed in Y-phase at Talcher PMU voltage data.
- After 12:36:19:120 hrs, another 25 kV voltage dip has been observed.
- Fault clearance time was approx. 400 ms.

Status of Reporting: Detail tripping report from OPTCL is received on 17-12-16.

OPTCL may explain the following:

- Reason for non-operation of bus bar protection for 220 kV Bus – II at Meramundali
- Reason for tripping of 220 kV Bhanjanagar – II, 220 kV Kaniha I & II from Meramundali end on zone 1

In 51st PCC, OPTCL explained the disturbance with a detailed presentation. OPTCL explained that

- *At 12.36 hrs, 220kV Y-ph Bus-2 PT at Meramundali S/s was busted and initiated the Bus fault.*
- *The Bus bar protection was out of service for maintenance. Hence, 220kV TTPS, Bhusan, Duburi and Nalco feeders tripped from remote end on zone 2.*
- *R-ph Voltage of 220KV bus shoot up as high as 235.25KV (Normal=127KV) Ph-E, Over Fluxing relay of 220/132 kV Auto-1 & 2 operated and tripped.*
- *Simultaneously, Bus PT fuse failed and the 220KV feeders Kaniha 1 & 2, Duburi 1 & 2 and Bhanjanagar-2 tripped by distance relay on zone 1.*
- *ICT-2 220KV side tripped by Overcurrent E/F protection. 400KV side R-Ph voltage shoot up as high as 356KV (Normal=231KV) Ph-E which resulted tripping of Angul-1 & 2, Vedanta- 2, Duburi 1 & 2 and Mendhasal on over voltage stage-I.*

PCC felt that distance relays should be blocked during PT fuse failure and it has been advised in several PCC meetings.

OPTCL informed that they have investigated and found a problem in CVT circuit. The same has been rectified after this disturbance.

Further PCC felt that the explanation given by OPTCL is not sufficient/satisfactory to get a proper conclusion. In view of that, PCC requested OPTCL to submit complete details along with all related DR files with their analysis at the earliest.

Regarding high voltage PCC felt that 235.25 kV ph-E voltage in 220kV system is huge and not possible to appear. PCC advised OPTCL to verify the values.

In view of frequent uncoordinated trippings at 400/220kV Meramundali S/s, PCC decided that a protection team should visit 400kV Meramundali S/s from 9th to 12th February, 2017 to review the protection system.

PCC advised ERLDC, NTPC, Powergrid, CESC and DVC to nominate a senior protection engineer for the visit.

OPTCL may update.

ITEM NO. C.2: Oscillations in CESC system at 01:57hrs on 07.01.2017.

At 01:57hrs on 07.01.2017, severe fluctuations to the tune of around 300MW were observed at the units of BBGS (Unit 2 & 3) and at synchronizing point, EMSS (Kasba). The following points observed during that time,

- Import at EMSS point fluctuated from +20MW to around -210MW(Export), reactive flow fluctuated between +20MVAR to -40MVAR(export)
- BBGS S/O fluctuated between 290MW to 600MW. Reactive absorption of BBGS fluctuated between -130MVAR to -210MVAR.
- SCE BBGS reported fluctuations between 115MW to 300MW in Unit 3 & between 170MW to 300MW in Unit 2.
- HEL also observed minor fluctuations in UNIT 2 to the tune of 10-15 MW

System Conditions prior to the incident:

- Export at EMSS point was around 60MW and reactive flow from EMSS point was NIL.
- Voltages (from SCADA at 01:45hrs- previous time block)
- BBGS (132kV) : 140.8kV
- BBGS (220kV) : 228.6kV
- EMSS (132kV) :137.0kV
- EMSS (220kV) : 237.0kV

In 51st PCC, CESC informed that at 01:57hrs on 07.01.2017, severe fluctuations to the tune of around 300MW were observed at the units of BBGS (Unit 2 & 3) and at synchronizing point, EMSS (Kasba). No tripping was initiated during the oscillations and the oscillations were died out gradually.

CESSC added that PSS tuning of Budge-Budge units were done in August 2016 in presence of Prof. S. V. Kulkarni from IIT Mumbai. This is the first incident after the PSS tuning.

ERLDC informed that they have observed the oscillations from Durgapur PMU plot and the dominant frequency component of the oscillations is 0.9 Hz.

After detailed discussion, PCC decided to convey the complete incidence details to Prof. S. V. Kulkarni, IIT Mumbai for further study/advice. PCC advised CESC to submit the details to ERPC and ERLDC.

Members may update.

ITEM NO. C.3: Protection Committee visit to BSPTCL and JUSNL Sub-stations

In view of repeated uncoordinated trippings in JUSNL systems

Protection settings of all the 220 kV & 132 kV lines along with the 220/132 kV ICTs of 220/132kV Ramchandrapur, Chandil & Hatia-II and 132 kV Adityapur & Hatia-I substations of JUSNL were finalized in a special meeting on 28.07.2016 by ERPC protection team. JUSNL was advised to implement the settings.

JUSNL vide mail dated 5th October 2016 informed that the relay settings have been changed for all the lines of 220kV Chandil, Ramchandrapur and 132kV Adityapur as per the ERPC committee recommendations. Latest status of implementation is enclosed at **Annexure-C3**

JUSNL may update.

ITEM NO. C.4: PROTECTION PHILOSOPHY OF EASTERN REGION

The Protection Philosophy finalized in special PCC meeting held on 20th July, 2015 is as given below:

Sl. No.	Zone	Direction	Protected Line Reach Settings	Time Settings (in Seconds)	Remarks
1	Zone-1	Forward	80%	Instantaneous (0)	As per CEA
2a	Zone-2	Forward	For single ckt- 120 % of the protected line	0.5 to 0.6 - if Z2 reach overreaches the 50% of the shortest line ; 0.35- otherwise	As per CEA
			For double ckt- 150 % of the protected line		As per CEA
2b	Zone-2 (for 220 kV and below voltage Transmission lines of utilities)	Forward	120 % of the protected line, or 100% of the protected line + 50% of the adjacent shortest line	0.35	As per CEA with minor changes
3	Zone-3	Forward	120 % of the (Protected line + Next longest line)	0.8 - 1.0	As per CEA
4	Zone-4	Reverse	10%- for long lines (for line length of 100 km and above) 20%- for shot lines (for line length of less than 100 km)	0.5	As per CEA

Note:

- 1) Zone-2:- Z2 Reach should not encroach the next lower voltage level.
- 2) Zone-3:- If Z3 reach encroaches in next voltage level (after considering “in-feed”), then Z3 time must be coordinated with the fault clearing time of remote end transformer.
- 3) Zone-4:- If utility uses carrier blocking scheme, then the Z4 reach may be increased as per the requirement. It should cover the LBB of local bus bar and should be coordinated with Z2 time of the all other lines.
- 4) The above settings are recommended primarily (exclusively) for uncompensated lines.

All the constituents agreed on the principles read with notes as above.

Till date DVC, WBSETCL, JUSNL, OPTCL, Powergrid (ER-I, ER-II & Odisha-Projects), NTPC, BSPTCL, NHPC, Vedanta and GMR had submitted the zone settings.

PCC advised all the other constituents to implement the revised zone philosophy and submit the settings to ERPC at the earliest.

JITPL, MPL and Adhunik may submit the revised zone settings data at the earliest.

ITEM NO. C.5: Third Party Protection Audit

1. Status of 1st Third Party Protection Audit:

The compliance status of 1st Third Party Protection Audit observations is as follows:

Name of Constituents	Total Observations	Complied	% of Compliance
Powergrid	54*	46	85.19
NTPC	16	14	87.50
NHPC	1	1	100.00

DVC	40	26	65.00
WB	68	27	39.71
Odisha	59	38	64.41
JUSNL	34	16	47.06
BSPTCL	16	5	31.25
IPP (GMR, Sterlite and MPL)	5	5	100.00

* Pending observations of Powergrid are related to PLCC problems at other end.

The substation wise status of compliance are available at ERPC website (Observations include PLCC rectification/activation which needs a comprehensive plan).

Members may update.

2. Schedule for 2nd Third Party Protection Audit:

The latest status of 2nd Third Party Protection audit is as follows:

1) Jeerat (PG)	Completed on 15 th July 2015
2) Subashgram (PG)	Completed on 16 th July 2015
3) Kolaghat TPS (WBPDCCL)-	Completed on 7 th August 2015
4) Kharagpur (WBSETCL) 400/220kV -	Completed on 7 th August 2015
5) Bidhannagar (WBSETCL) 400 & 220kV	Completed on 8 th September, 2015
6) Durgapur (PG) 400kV S/s	Completed on 10 th September, 2015
7) DSTPS(DVC) 400/220kV	Completed on 9 th September, 2015
8) Mejia (DVC) TPS 400/220kV	Completed on 11 th September, 2015
9) 400/220/132kV Mendhasal (OPTCL)	Completed on 2 nd November, 2015
10) 400/220kV Talcher STPS (NTPC)	Completed on 3 rd November, 2015
11) 765/400kV Angul (PG)	Completed on 4 th November, 2015
12) 400kV JITPL	Completed on 5 th November, 2015
13) 400kV GMR	Completed on 5 th November, 2015
14) 400kV Malda (PG)	Completed on 23 rd February, 2016
15) 400kV Farakka (NTPC)	Completed on 24 th February, 2016
16) 400kV Behrampur(PG)	Completed on 25 th February, 2016
17) 400kV Sagardighi (WBPDCCL)	Completed on 25 th February, 2016
18) 400kV Bakreswar (WBPDCCL)	Completed on 26 th February, 2016
19) 765kV Gaya(PG)	Completed on 1 st November, 2016
20) 400kV Biharshariff(PG)	Completed on 3 rd November, 2016
21) 220kV Biharshariff(BSPTCL)	Completed on 3 rd November, 2016

It was informed that the third party protection audit observations are available in the ERPC website in important documents.

PCC advised all the constituents to comply the observations at the earliest.

Members may update.

ITEM NO. C.6: Implementation of Protection Database Management System Project.

ERPC proposal for "Creation & Maintenance of web based protection database management system and desktop based protection calculation tool for Eastern Regional Grid" has been approved by the Ministry of Power for funding from Power System Development Fund (PSDF) vide No-10/1/2014-OM dated 07.03.2016.

In 49th PCC, PRDC informed that data collection for West Bengal is in progress and it will be completed by December, 2016.

In 50th PCC, It was informed that Software Acceptance Tests are in progress.

In 51st PCC, PRDC informed that data collection of Odisha and Jharkhand has been completed. Data collection in West Bengal and Bihar is in progress. Data collection of Eastern Region will be completed by 15th February 2017.

PRDC added that software acceptance trails of PSCT phase-I have been completed and phase-II will be done from 19th to 21st January 2017. Software acceptance trails of web based PDMS system have been completed and observations will be implemented at the earliest.

It was informed that a format for on-line reporting of tripping incidence has been prepared in PDMS and PRDC will present details in next PCC meeting.

PRDC may update.

ITEM NO. C.7: Zone-2 setting of long line followed by short line

As per ERPC/CEA protection guidelines Zone-2 time setting of two adjacent lines needs to be properly co-ordinated to avoid undesirable trippings on account of racing between relays. In the past major disturbances occurred due to lack of proper coordination in Zone-2 time setting.

For proper coordination of operation of Zone-2 Distance Protection, an effort has been made to list out the adjacent shortest line for 400 kV transmission lines, and all the lines whose Zone-2 reach is overlapping with that of adjacent lines have been highlighted. The details are given in **Annexure-C7**.

Concerned transmission utilities are requested to review the same and share the present Zone-2 time setting and update in case of mismatch.

In 48th PCC, all the constituents were advised to go through the Annexure and review the settings with intimation to ERPC and ERLDC.

Members may update.

ITEM NO. C.8: Line over voltage protection settings for 400 kV and 765 kV Lines in Eastern Region

Last year over voltage protection setting for all 400 kV and above lines was collected from the constituents. However, in the meantime many changes took place in the system, which includes commissioning of new lines as well as LILO of existing line.

Further CEA guidelines suggest that the following should be considered while setting over voltage protection in transmission line.

FOR 400kV LINES: Low set stage (Stage-I) may be set in the range of 110% - 112% (typically 110%) with a time delay of 5 seconds. High set stage (Stage-II) may be set in the range 140% - 150% with a time delay of 100milliseconds.

FOR 765kV LINES: Low set stage (Stage-I) may be set in the range of 106% - 109% (typically 108%) with a time delay of 5 seconds. High set stage (Stage-II) may be set in the range 140% - 150% with a time delay of 100milliseconds.

However, for over voltage Stage-I protection, a time grading of 1 to 3 seconds may be provided between overvoltage relays of double circuit lines. Grading on overvoltage tripping for various lines emanating from a station may be considered and same can be achieved using voltage as well as time grading. Longest timed delay should be checked with expected operating time of Over-fluxing relay of the transformer to ensure disconnection of line before tripping of transformer.

It is desirable to have Drop-off to pick-up ratio of overvoltage relay better than 97% (Considering limitation of various manufacturers relay on this aspect).

Present overvoltage setting record available at ERLDC is given in **Annexure-C8**. Concerned transmission utilities are requested to provide the missing information and updated the existing one (if any).

In 48th PCC, all the constituents were advised to go through the Annexure and update the settings, if any.

Members may update.

ITEM NO. C.9: Non-commissioning of PLCC / OPGW and non-implementation of carrier aided tripping in 220kV and above lines.

According to CEA technical standard for construction of electric plants and electric lines -Clause 43(4) (c), transmission line of 220 KV and above should have single-phase auto-reclosing facility for improving the availability of the lines. However, from the tripping details attached June-August, 2016 it is evident that the some of 220kV above Inter & Intra-Regional lines do not having auto-reclose facility either at one end or at both ends. Out of these for some of the lines even PLCC/OPGW is not yet installed and carrier aided protection including Autorecloser facility is not yet implemented. Based on the trippings of June- August, 2016 and PMU analysis a list of such lines has been prepared and as given below:

List of line where auto reclose facility is not available(Information based on PMU data analysis)								
S. No	Transmission Lines name	Date of Tripping	Reason of Tripping	Owner Detail		Present Status		
				End-1	End-2	OPGW/PLCC Link available	AR facility functional	
1	400 KV ANGUL - TALCHER	02.06.16	B-N FAULT	PGCIL	NTPC			
2	400 KV BIHARSARIFF-VARNASI-I	07.06.16	B-N FAULT	PGCIL	PGCIL	PLCC available	Functional (10.11.2016)	
3	400KV BIHARSARIFF - BANKA-II	12.06.16	Y - N FAULT	PGCIL	PGCIL	PLCC available	Functional (25.09.2016)	
4	220KV SASARAM-SAHUPURI	12.06.16	B - N FAULT	PGCIL	UPTCL	PLCC available	Functional at Pusauli	
5	400 KV TALA -BINAGURI -IV	13.06.16	B - N FAULT	Durk Green	PGCIL		Tala end AR is disabled.	
6	400 KV KODERMA-BOKARO-I	14.06.16	B-N FAULT	DVC	DVC	PLCC available		
7	400 KV FARAKKA-KAHALGAON-IV	15.06.16	R-N FAULT	NTPC	NTPC	Yes	Yes and operated last on dated 28.09.2016.	
8	400 KV MUZAFFARPUR-BIHARSARIFF-II	17.06.16	Y-N FAULT	PGCIL	PGCIL	PLCC available	Functional (08.10.2016)	
9	400 KV MERAMUNDALI-NEWDUBRI - I	20.06.16	B-N FAULT	OPTCL	OPTCL	PLCC available	Yes	
10	400KV PATNA-BALIA-II	21.06.16	B-N FAULT	PGCIL	PGCIL			
11	400KV PATNA-KISHANGANJ-II	21.06.16	Y-N FAULT	PGCIL	PGCIL	PLCC available	Functional (21.06.2016)	
12	400KV PATNA-BALIA-I	21.06.16	R-N FAULT	PGCIL	PGCIL	PLCC available		
13	220KV BUDIPADAR-KORBA-II	23.06.16	Y-N FAULT	OPTCL	CSEB	PLCC available	will be activated	

							consultation with Korba
14	400 KV ARAMBAGH - BIDHANNAGAR	02.07.16	Y-N FAULT	WBSET CL	WBSET CL		
15	400 KV FARAKKA-DURGAPUR-I	06.07.16	Y-N FAULT	NTPC	PGCIL	Yes	Yes and operated last on 19.07.2016 & 06.11.2016
16	400 KV NEW RANCHI - CHANDWA - I	13.07.16	B-N FAULT	PGCIL	PGCIL	PLCC available	
17	220 KV TSTPP-RENGALI	17.07.16	EARTH FAULT	NTPC	OPTCL		
18	220KV BUDIPADAR-RAIGARH	21.07.16	EARTH FAULT	OPTCL	PGCIL	PLCC defective	
19	400 KV KOLAGHAT-KHARAGPUR	03.08.16	Y-N FAULT	WBPDC L	WBSET CL		
20	220 KV FARAKKA-LALMATIA	03.08.16	B-N FAULT .	NTPC	JUNSL	Yes	Old Relay and not functional. 7-8 months required for auto re-close relay procurement.
21	400 KV PURNEA-MUZAFARPUR-I	03.08.16	R-N FAULT	PGCIL	PGCIL	PLCC available	
22	400 KV GAYA - CHANDWA -II	04.08.16	B-N FAULT .	PGCIL	PGCIL	PLCC available	Functional (01.09.2016)
23	220 KV MUZAFFARPUR - HAZIPUR - II	10.08.16	B-N FAULT	PGCIL	BSPTCL		
24	220 KV ROURKELA - TARKERA-II	11.08.16	B-N FAULT	PGCIL	OPTCL	OPGW available	Expected to install protection coupler by Jan 17
25	220 KV CHANDIL-SANTALDIH	25.08.16	R-N FAULT	JUNSL	WBPDC L		
26	400 KV MPL-RANCHI-II	02.09.16	R-N FAULT	MPL	PGCIL	PLCC available	
27	220 KV BIHARSARIF-TENUGHAT	07.09.16	B-N FAULT	BSPTCL	TVNL		
28	400KV MERAMANDALI-STERLITE-II	10.09.16	Y-N FAULT	OPTCL	SEL	OPGW not commissioned	
29	220 KV RAMCHANDRAPUR - CHANDIL	22.09.16	B-N FAULT	JUNSL	JUNSL		
30	400KV SEL MERAMUNDALI-I	22.09.16	B-N FAULT	SEL	OPTCL	OPGW not commissioned	
31	400 KV KOLAGHAT - CHAIBASA	28.09.16	B-N FAULT	WBPDC L	PGCIL	PLCC available	

34th TCC advised all the respective members to update the above list along with the last tripping status in next PCC meeting.

TCC further advised all the constituents to give the latest status of PLCC of other 220kV and above lines under respective control area.

TCC advised to review the status of above in lower forums report back in next TCC.

PCC advised Powergrid, DVC, NTPC, WBSETCL, WBPDC, JUSNL, BSPTCL, MPL and SEL to communicate the latest status along with the last tripping status to ERPC and ERLDC.

Members may update the status.

ITEM NO. C.10: Non-commissioning / non-functional status of bus-bar protection at important 220 kV Sub-stations.

It has been observed that at many 220 kV substations particularly that of STU, bus-bar protection is either not commissioned or non-functional. The non-availability / non-functionality of bus bar protection, results in delayed, multiple and uncoordinated tripping, in the event of a bus fault. This in turn not only results in partial local black out but also jeopardises the security of interconnected national grid as a whole. The matter was also pointed out during the third party protection audit which is being carried out regularly. Constituents are required to meet the audit compliance and commission or made bus –bar protection functional where ever it is not available. A list of such important 220 kV sub-stations as per the first third party audit is placed in the meeting.

In 34th TCC, members updated the status as follows:

Bus Bar Protection not available (reccord as per third party protection audit)

Bihar				
SI No	Name of Substation	Bus protection status	Date of audit	Present Status
1	220 kV Bodhgaya	Not available	28-Dec-12	<i>Single bus and there is no space available for busbar protection</i>
Jharkhand				
1	220 kV Chandil	Not available	29-Jan-13	<i>LBB available</i>
2	220 kV Tenughat	Not available	12-Apr-13	
DVC				
1	220 kV Jamsedpur	Not available	10-Apr-13	<i>Single bus. Bus bar will be commissioned under PSDF.</i>
West Bengal				
1	220 kV Arambah	Not available	24-Jan-13	<i>Available in alarm mode. Planning to replace with numerical relay</i>
2	220 kV Jeerat	Not available	20-Dec-12	<i>Relays have been received at site. Installation is in progress.</i>

TCC further advised all the constituents to give the latest status of Bus Bar protection of other 220KV S/S under respective control area.

TCC advised to review the status of above in lower forums report back in next TCC.

Members may update.

ITEM NO. C.11: Disturbance at 400/220 kV Meramundali (OPTCL) S/s on 05-10-16 at 18:10 hrs.

In 49th PCC, OPTCL was advised to carry out the following:

- *PT selection scheme during bus change over should be checked and modified.*
- *Verify the PT fuse supervision settings in Micom relays of 220 kV lines and advised to enable if it was not enabled.*
- *Submit the DR of 220kV Meramundali-Bhanjanagar line-I at Meramundali end.*

OPTCL added that they have already installed the line CVT in 220kV Kaniha line and they are planning to install the line CVTs in all the other 220kV lines.

OPTCL may update.

ITEM NO. C.12: Frequent Blackouts at Kanti TPS

PCC advised Powergrid to revise the zone 3 time setting at Muzaffarpur (PG) end as per protection philosophy of ERPC at the earliest. PCC also advised Powergrid to implement the PLCC scheme for 220kV Muzaffarpur-Kanti D/C line at the earliest.

51st PCC, NTPC informed that PLCC has been installed in 220kV Kufen line.

PCC advised BSPTCL to install PLCC system for all the transmission lines connected to 220kV Gopalgunj, Darbhanga and Begusarai and enable the carrier tripping for reliable protection.

Members may update.

ITEM NO. C.13: Members may update the following:

1. OPTCL may please update the latest status on following substations:

In last PCC, OPTCL informed that

- OPTCL informed that they will review the logic of all the newly installed LBB protection: Old distance protection relays in 132kV system at 220kV Tarkera S/s will be replaced after replacing old relays at 220kV level: *The replacement work of relays at Tarkera is in progress*
- In 48th PCC, OPTCL was advised to change non directional over current E/F relays in 132 KV lines at 220/132kV Tarkera S/s with directional relays.

In 50th PCC, OPTCL informed that old EM type distance relays have been replaced with new numerical relays at 220kV Tarkera S/s except 132kV Rourkela line-1.

OPTCL may update.

2. Disturbance at 400/220kV Indravati (PG) and 400/220kV Indravati (OPTCL) S/s on 11-06-16 at 19:59 hrs.

In 45th PCC, OHPC, was advised the following:

- OHPC should check and restore the bus bar protection at 220 kV Indravati (OHPC) S/s.--- *OHPC informed that they will test the bus bar protection of 220 kV Indravati (OHPC) S/s on 25th Aug, 2016.*
- PCC felt that 400/220kV ICT-I&II should clear the fault on backup overcurrent protection before tripping of 400kV lines from PG end and advised OHPC to install directional O/C relays at both HV & LV side of 400/220kV ICT-I&II. Proper time coordination should be done with the adjacent line relays.

OHPC may update.

3. Disturbance at 220/132 kV NJP System on 01.09.2016 at 09:40 hrs.

In 48th PCC, it was felt that tripping of both the 220kV NJP (POWERGRID) lines for a fault in one bus section is not in order and advised WBSETCL to review the busbar protection scheme.

PCC also advised WBSETCL to submit the enquiry committee report on malfunction of 220 kV Isolator arm driving mechanism of 220/132 kV ATR I.

WBSETCL may update.

PART- D

Item No D.1 Tripping incidences in the month of January, 2017

Other tripping incidences occurred in the month of January 2017 which needs explanation from constituents of either of the end is given at **Annexure- D1**.

Members may discuss.

Item No D.2 Any other issues.

REPORT FOR 220 KV Chandil, Ramchandrapur and 132 KV ADITYAPUR GSS

1. STATUS OF IMPLEMENTATION OF RECOMMENDED SETTINGS FOR LINES AND ICT AT 220 KV CHANDIL, RAMCHANDRAPUR & 132 KV ADITYAPUR SUBSTATIONS.

Recommended settings given by ERPC are already been implemented for all the lines and ICT's 220 KV Chandil, Ramchandrapur and 132 KV Adityapur GSS's. this has been intimated to ERPC by the mail dated 05.10.2016 (mail copy attached), for which we have even received thanking mail back from the ERPC.

2. BEHAVIOUR OF PROTECTION SYSTEM POST RECOMMENDATION PERIOD.

After the implementation of the recommended settings given by ERPC, we have noticed a genuine improvement in the stability of the system of the system with the decrease in the unwanted tripping also.

3. STATUS OF OVERALL IMPLEMENTATION OF RECOMMENDATIONS OF THE PROTECTION TEAM.

The status of the overall implementation of recommendations of the protection team are as follows.

- Point No. 1- The requirement of Control Panels having Main-1 And Main-2 Distance Protection Scheme are already been forwarded to Transmission O & M, JUSNL, Ranchi for its procurement. It will be implemented after the availability of the panels.
- Point No.2- For having Distance Protection Relay and Back up OC/EF Protection Relay feature in single panel needs new Panels for which LOI has already has been issued by Transmission O & M JUSNL, Ranchi. It will be commissioned after its availability.
- Point No.3- For enabling these features, settings have already been uploaded to the various relay as per ERPC philosophy.
- Point No. 4- Single Phase Auto Reclosing features of 220 KV Ramchandrapur-Chandil Line, 220 KV Chandil -PGCIL Line are already in operation, however for 220 KV Chandil-STPS Line and 220 KV Ramchandrapur- Joda Line, arrangements are completed form our side and we are waiting for it completion report form the other side.
- Point No.5- Requirement of New Panels are already been sent to Nigam Headquarters, LOI has already been issued by CE, O & M, Transmission, Ranchi. It will be commissioned after its availability.
- Point No. 6- GPS System in 220 KV Ramchandrapur and 220 KV Chandil are already been commissioned.
- Point No. 7- At 220 KV Ramchandrapur S/S, Bus Bar Protection is already working properly. In 220 KV Chandil S/S, there is no provision for the second Bus, so Bus Bar Protection is not seems to be possible. However LBB are commissioned in all feeder and an order has already been placed to Alstom T&D for the connection and configuration of LBB and it will be complete after their arrival.
- Point No. 8- Tender for procurement of DC Earth Fault location for locating DC earth fault has already been floated, it will be procured shortly.
- Point No. 9- Panel Indications are working in all feeders.
- Point No.10- All the Pre and post Close Circuit supervision for Trip Coil-1 and Trip Coil-2 are healthy

- Point No. 11- Annunciation Circuitry for all trip and not trip functions are working as per schematic.
- Point No. 12- Old CTJB, PTJB are replaced with new JB's and even the terminations of the cables are also completed in both the sub stations.
- Point No.13- Most of the Panel diagrams are available at all the sub stations.
- Point No.14- Old Panels are soon to be replaced with the new ones, so no need of removal of redundant relay.
- Point No.15- Some 220 KV CT's having old and abnormal Tan Delta characteristics along with 220 KV ICT-I at 220 KV RCP Breakers are being replaced and work order are already been issued for the same.
- Point No.16- Earth Resistance of Sub Stations are measured at regular intervals and most of them are under the limit.
- Point No.17- Two sources of DC are available at 220 KV Ramchandrapur S/s and working properly. At 220 KV Chandil, other set of Battery has already been supplied and will be commissioned very soon after the arrival of its charger.
- Point No.18- Earth wire/OPGW is available in all 220 KV and 132 KV Transmission Lines This is for your kind information and needful action.



REPORT OF 132 KV HATIA-1 and 220 KV Hatia-2 Grid Sub Stations

1. Recommended setting for lines and ICTs at 220 KV Hatia-II and 132 KV Hatia-I has been implemented by CRITL, Ranchi.
2. Till date behaviour of protection system has been found satisfactory.
3. Status and roadmap for implementation of recommendation of protection team are as follows:-

Sl. No.	Recommendation	Status
(i)	Take suitable measure for detection and rectification of the DC earth fault.	Complied
(ii)	To carry out relay coordination as per the revised protection philosophy of ERPC.	Complied as per recommendation settings provided by ERPC.
(iii)	To complete the DPR for PSDF funding towards improvement/development of JUSNL protection system at the earliest.	Tender has been floated by HQ. for appointment of consultant.
(iv)	As per PART 3 of CEA (Technical Standards for connectivity of The Grid) Regulation, 2007, wherein it is clearly mentioned that 220 KV Transmission lines have both Main 1 and Main 2 Distance Protection Schemes applicable for New Sub-Stations and for the Old Sub-Stations, it should be implemented in a reasonable time frame. The Same should be implemented.	Complied
(v)	One Number Numerical Distance Protection Relay has been used for 132 KV Feeders. One Numerical Distance Protection Relay and another Back-up O/C and E/F protection relay (Two Separate units) should be used.	Complied at 220/132 KV GSS Hatia-II. For 132/33 KV GSS, procurement is under process at HQ. Level.
(vi)	In order to provide protection in case of high resistive fault, earth fault protection may be used where Main 1 and Main 2 protection is suggested i.e. for 220 KV Transmission lines. The characteristics should be IDMT (Normal Inverse). The ground over current threshold should be set to ensure detection of all ground faults, but above any continuous residual current under normal system operation. The timing should be coordinated with the Zone-3 timing for a remote end bus fault.	Complied
(vii)	Availability of carrier protection and single phase Auto-reclose for all 220 KV and above transmission lines.	Complied
(viii)	Replacement of Electromechanical Relays with Numerical Relays, wherever applicable for Transmission lines and transformers.	Complied at 220 KV & 132 KV Line. For 33 KV, Procurement of Numerical Relays is under processed.

(ix)	Connectivity of GPS clock in every Sub-Station with Time synchronisation facility to the Numerical Relays.	Implemented at 220/132 KV GSS Hatia-II. Rest are under process. Completed by 31-01-17
(x)	As per PART 3 of CEA (Technical Standards for connectivity of The Grid) Regulation, 2007, wherein it is clearly mentioned that Bus bar protection shall be [provided on all Sub-Stations at and above 220 KV leaves for all new Sub-Stations. For existing Sub-Stations, this shall be implemented in a reasonable time frame. (i) Local Breaker Back-up (LBB) protection shall be provided for all Sub-Stations of 220 KV and above.	Complied
(xi)	All panel indications wherever applicable for Isolators, Breakers, Circuit Breaker Spring Charge, Trip Circuit Healthy or any other indications as per the scheme should be made healthy.	Complied
(xii)	Pre and Post Close Trip circuit supervision for trip coil 1 (TC#1) and trip coil 2 (TC#2) should be made healthy wherever applicable.	Complied
(xiii)	Annunciation circuitry should be made proper for all trip and non-trip functions as per the schematic.	Complied
(xiv)	CTJB, PTJB should be changed wherever applicable and terminations of the cables should be completed with proper specification of Terminal Blocks and LUGS. The CTJB and PTJB should be earthed through earthing strips.	Procurement of JB for Hatia-I & Namkum is under process. Completed by 31-03-17.
(xv)	All relevant drawings required during trouble shooting should be made available in each of the control rooms of every sub-stations. (i) Update Drawings related to protection and Control Panel of individual bays, CT's PT's, Circuit breakers, Isolators, Transformers etc. are to be made available at sub-station level. (ii) LOGICS and configuration of the Numerical Relays should be made proper with the availability of relevant protection as per CEA guidelines and the same should be made available at the sub-Station level.	Available
(xvi)	Redundant relays which are not in use should be removed from the protection panels and the Numerical Relays and Auxiliaries installed should be newly wired as per the approved scheme.	Under Process. Completed by 31-01-2017.
(xvii)	220 KV and 132 KV CT's should be tested for characteristics and proper core should be used for proper protection purpose, i.e. PS for Differential, 5P for Distance/Backup protection, 0.2/0.5 for metering purpose. Kindly note that for booth 220 KV and 132 KV CT protection schemes, separate cores should be used for separate protection purpose.	Complied
(xviii)	Earth resistance of sub-station should be measures at regular intervals and the value should be less than 1 ohms. The result should be marked in the sub-station earth pit with the date of	Complied



	testing.	
(xix)	Two source of D.C may be provided to control and relay panels for 220 KV and above system for security and redundancy. Accordingly the Bus wire of the panel is to be segregated and scheme developed accordingly.	Complied
(xx)	<p>Meticulous Patrolling of 220 KV and 132 KV Transmission Lines along with availability of earth wires should be ensured to reduce transient faults.</p> <p>(i) Individual Tower Earthing should also be ensured to provide earth paths to lighting strikes through the shortest path.</p> <p>(ii) Regular Conditioning monitoring of sub-station equipment (Transformer, CT, CVT, PT, LA, CB, etc.) may be done as per CEA recommendation and proper record may be maintained</p> <p>(iii) The types of taste on the sub-station equipments along with the technology used with its duration is provided and the same should be meticulously followed for all 220 KV and 132 KV Sub-Station.</p>	Complied

Annexure-C7

SL No	Zone-2 timer setting at	For line	No of circuits	Length (km)	Zone-2 Reach in %	Zone-2 reach of protected line length (km)	Shortest line at remote end	Length (km)	Considering Ideal Zone-1 reach i.e Upto 80%			Considering Zone-1 under reaches by 30% i.e. Zone -1 reach is only upto 50% (as per ERPC/CEA philosophy)		
									Zone-2 reach (Beyond 80% upto 120/150%) of the shortest line Starts at (km)	Zone -2 Overlap ?	Zone-2 Time setting	Zone-2 reach (Beyond 50% upto 120/150%) of the shortest line Starts at (km)	Zone -2 Overlap ?	Zone-2 Time setting
1	Muzaffarpur	Gorakhpur	D/C	261	150%	392	Gorakhpur-Gorakhpur-UP D/C	46	37	Y	0.5 to 0.6	23	Y	0.5 to 0.6
		Biharshariff	D/C	133	150%	200	Biharsariff Lakhisarai D/C	89	71	N	0.35	45	Y	0.5 to 0.6
		Purnea	D/C	242	150%	363	Purnea-Kishanganj D/C	71	57	Y	0.5 to 0.6	36	Y	0.5 to 0.6
2	Purnea	Muzaffarpur	D/C	242	150%	363	Muzaffarpur-Biharsariff D/C	133	107	Y	0.5 to 0.6	67	Y	0.5 to 0.6
		Kishanganj	D/C	71	150%	107	Kishanganj-Purnea other ckt	71	57	N	0.35	36	N	0.35
		Biharsariff	D/C	231	150%	347	Biharsaiff-Lakhisarai D/C	89	71	Y	0.5 to 0.6	45	Y	0.5 to 0.6
		Malda	D/C	167	150%	251	Malda-Farraka D/C	40	32	Y	0.5 to 0.6	20	Y	0.5 to 0.6
		Binaguri	D/C	168	150%	252	Binaguri-Kishanhanj D/C	98	78	Y	0.5 to 0.6	49	Y	0.5 to 0.6
3	Kishanganj	Purnea	D/C	71	150%	107	Purnea Kishanganj other ckt	71	57	N	0.35	36	N	0.35
		Patna	D/C	348	150%	521	Patna-Barh D/C	69	55	Y	0.5 to 0.6	34	Y	0.5 to 0.6
		Binaguri	D/C	98	150%	147	Binaguri-Kishanhanj other ckt	98	78	N	0.35	49	N	0.35
4	Barh	Patna	D/C	93	150%	140	Patna-Barh D/C	69	55	N	0.35	34	Y	0.5 to 0.6
		Patna	D/C	69	150%	103	Patna-Barh other ckt	69	55	N	0.35	34	N	0.35
		Gorakhpur	D/C	349	150%	524	Gorakhpur-Gorakhpur-UP D/C	46	37	Y	0.5 to 0.6	23	Y	0.5 to 0.6
		Kahalgaon	D/C	217	150%	326	Khalgaon-BankaD/C	48	38	Y	0.5 to 0.6	24	Y	0.5 to 0.6
5	Patna	Kishanganj	D/C	348	150%	521	Kishanganj-Purnea D/C	71	57	Y	0.5 to 0.6	36	Y	0.5 to 0.6
		Barh	D/C	93	150%	140	Barh-Patna D/C	69	55	N	0.35	34	Y	0.5 to 0.6
		Barh	D/C	69	150%	103	Barh-Patna other ckt	69	55	N	0.35	34	N	0.35
		Balia	D/C	185	150%	278	Balia-Mau D/C	9	7	Y	0.5 to 0.6	5	Y	0.5 to 0.6
		Balia	D/C	195	150%	293	Balia-Mau D/C	9	7	Y	0.5 to 0.6	5	Y	0.5 to 0.6
6	Sasaram	Biharsariff	D/C	210	150%	315	Biharsaiff-Lakhisarai D/C	89	71	Y	0.5 to 0.6	45	Y	0.5 to 0.6
		Nabinagar	D/C	82	150%	123	Sasaram-Nabinagar D/C	82	66	N	0.35	41	N	0.35
		Varanasi	S/C	143	120%	172	Varansi-Saranathi S/C	70	56	N	0.35	35	N	0.35
		Allahabad	S/C	212	120%	254	Allahabad-Varanasi S/C	98	78	N	0.35	49	N	0.35
7	Gaya	Maithon	D/C	276	150%	414	Maithon-MPL D/C	32	25	Y	0.5 to 0.6	16	Y	0.5 to 0.6
		Chandwa	D/C	117	150%	176	Chandwa-N.Ranchi D/C	68	54	Y	0.5 to 0.6	34	Y	0.5 to 0.6
		Koderma	D/C	125	150%	188	Koderma-Bokaro D/C	100	80	N	0.35	50	Y	0.5 to 0.6
8	Biharsariff	Muzaffarpur	D/C	133	150%	200	Muzaffarpur-Biharsariff D/C	133	107	N	0.35	67	N	0.35
		Purnea	D/C	231	150%	347	Purnea Kishanganj D/C	71	57	Y	0.5 to 0.6	36	Y	0.5 to 0.6
		Sasaram	D/C	210	150%	315	Sasaram-Nabinagar D/C	82	65	Y	0.5 to 0.6	41	Y	0.5 to 0.6
		Lakhisari	D/C	89	150%	134	Lakhisarai-Biharsaiff Other ckt	89	71	N	0.35	45	N	0.35
		Banka	D/C	185	150%	277	Banka-Khalgaon D/C	48	38	Y	0.5 to 0.6	24	Y	0.5 to 0.6
		Koderma	D/C	111	150%	166	Koderma-Bokaro D/C	100	80	N	0.35	50	Y	0.5 to 0.6
		Balia	D/C	241	150%	362	Balia-Mau D/C	9	7	Y	0.5 to 0.6	5	Y	0.5 to 0.6
9	Lakhisari	Biharsariff	D/C	89	150%	134	Biharsaiff-Lakhisarai D/C	89	71	N	0.35	45	N	0.35
		Kahalgaon	D/C	145	150%	218	Khalgaon-BankaD/C	48	38	Y	0.5 to 0.6	24	Y	0.5 to 0.6
10	Banka	Biharsariff	D/C	185	150%	277	Biharsaiff-Lakhisarai D/C	89	71	Y	0.5 to 0.6	45	Y	0.5 to 0.6
		Kahalgaon	D/C	48	150%	72	Khalgaon-BankaD/C	48	38	N	0.35	24	N	0.35
		Lakhisari	D/C	145	150%	218	Lakhisarai-Biharsaiff D/C	89	71	Y	0.5 to 0.6	45	Y	0.5 to 0.6
		Banka	D/C	48	150%	72	Banka-Khalgaon Other ckt	48	38	N	0.35	24	N	0.35

11	Khalgaon	Farraka	D/C	95	150%	143	Farraka -Malda D/C	40	32	Y	0.5 to 0.6	20	Y	0.5 to 0.6
		Farraka	D/C	95	150%	143	Farraka -Malda D/C	40	32	Y	0.5 to 0.6	20	Y	0.5 to 0.6
		Maithon	D/C	172	150%	258	Maithon-MPL D/C	32	25	Y	0.5 to 0.6	16	Y	0.5 to 0.6
12	Farraka	Khalgaon	D/C	95	150%	143	Khalgaon-BankaD/C	48	38	Y	0.5 to 0.6	24	Y	0.5 to 0.6
		Khalgaon	D/C	95	150%	143	Khalgaon-BankaD/C	48	38	Y	0.5 to 0.6	24	Y	0.5 to 0.6
		Malda	D/C	40	150%	60	Malda-Farraka D/C	40	32	N	0.35	20	N	0.35
		Bahrapur	S/C	71	120%	85	Bahrapur-Sagardighi D/C	26	21	N	0.35	13	Y	0.5 to 0.6
		Sagardighi	S/C	72	120%	86	Sagardighi-Bahrapur D/C	26	21	N	0.35	13	Y	0.5 to 0.6
		Durgapur	D/C	146	150%	219	Durgapur-Bidhannagar D/C	11	9	Y	0.5 to 0.6	6	Y	0.5 to 0.6
13	Malda	Purnea	D/C	167	150%	251	Purnea Kishangaj D/C	71	57	Y	0.5 to 0.6	36	Y	0.5 to 0.6
		Farraka	D/C	40	150%	60	Farraka -Malda D/C	40	32	N	0.35	20	N	0.35
14	Binaguri	Purnea	D/C	168	150%	252	Purnea Kishangaj D/C	71	57	Y	0.5 to 0.6	36	Y	0.5 to 0.6
		Kishanganj	D/C	98	150%	147	Kishanganj-Purnea D/C	71	57	N	0.35	36	Y	0.5 to 0.6
		Rangpo	D/C	12	150%	18	Rangpo-Binaguri D/C	12	9	N	0.35	6	N	0.35
		Bongaigaon	D/C	218	150%	327	Bongaigaon-BTPS D/C	3.12	2	Y	0.5 to 0.6	2	Y	0.5 to 0.6
		Bongaigaon	D/C	221	150%	332	Bongaigaon-BTPS D/C	3.12	2	Y	0.5 to 0.6	2	Y	0.5 to 0.6
		Tala	D/C	145	150%	218	Tala -Malbase S/C	24	19	Y	0.5 to 0.6	12	Y	0.5 to 0.6
		Tala	S/C	140	120%	168	Tala -Malbase S/C	24	19	Y	0.5 to 0.6	12	Y	0.5 to 0.6
15	Bahrapur	Malbase	S/C	125	120%	150	Malbase -Tala S/C	24	19	Y	0.5 to 0.6	12	Y	0.5 to 0.6
		Farraka	S/C	71	120%	85	Farraka -Malda D/C	40	32	N	0.35	20	N	0.35
		Sagardighi	D/C	26	150%	39	Sagardighi-Bahrapur D/C	26	21	N	0.35	13	N	0.35
		Jeerat	S/C	165	120%	198	Jeerat-Subhasgram S/C	63	50	N	0.35	32	Y	0.5 to 0.6
16	Sagardighi	Bheramara	D/C	100	150%	150	Bheramara-Bahrapur other ckt	100	80	N	0.35	50	N	0.35
		Farraka	S/C	72	120%	86	Farraka -Malda D/C	40	32	N	0.35	20	N	0.35
		Bahrapur	D/C	26	150%	39	Bahrapur-Sagardighi D/C	26	21	N	0.35	13	N	0.35
		Durgapur	D/C	128	150%	192	Durgapur-Bidhannagar D/C	11	9	Y	0.5 to 0.6	6	Y	0.5 to 0.6
17	Durgapur	Subhasgram	S/C	246	120%	295	Subhasgram-Jeerat S/C	63	50	N	0.35	32	Y	0.5 to 0.6
		Farraka	D/C	146	150%	219	Farraka -Malda D/C	40	32	Y	0.5 to 0.6	20	Y	0.5 to 0.6
		Sagardighi	D/C	128	150%	192	Sagardighi-Bahrapur D/C	26	21	Y	0.5 to 0.6	13	Y	0.5 to 0.6
		Bidhannagar	D/C	11	150%	17	Bidhannagar-Durgapur D/C	11	9	N	0.35	6	N	0.35
		Jamsedpur	S/C	177	120%	212	Jamsedpur - Adhunik D/C	1	0	Y	0.5 to 0.6	0	Y	0.5 to 0.6
18	Bidhannagar	Maithon	D/C	71	150%	106	Maithon-MPL D/C	32	25	Y	0.5 to 0.6	16	Y	0.5 to 0.6
		Durgapur	D/C	11	150%	17	Durgapur-Bidhannagar D/C	11	9	N	0.35	6	N	0.35
		PPSP	D/C	185	150%	278	PPSP-Bidhannagar D/C	185	148	N	0.35	93	N	0.35
19	PPSP	Arambagh	S/C	114	120%	137	Arambag-Kolaghat S/C	64	51	N	0.35	32	N	0.35
		Bidhannagar	D/C	185	150%	278	Bidhannagar-Durgapur D/C	11	9	Y	0.5 to 0.6	6	Y	0.5 to 0.6
20	Arambagh	Arambagh	D/C	210	150%	315	Arambag-Kolaghat S/C	64	51	Y	0.5 to 0.6	32	Y	0.5 to 0.6
		Bidhannagar	S/C	114	120%	137	Bidhannagar-Durgapur D/C	11	9	Y	0.5 to 0.6	6	Y	0.5 to 0.6
		PPSP	D/C	210	150%	315	PPSP-Bidhannagar D/C	185	148	N	0.35	93	Y	0.5 to 0.6
		Bakreswar TPS	S/C	130	120%	156	Arambag-Bakreswar S/C	130	104	N	0.35	65	N	0.35
21	Bakreswar TPS	Kolaghat TPS	S/C	64	120%	77	Kolaghat-Arambagh S/C	64	51	N	0.35	32	N	0.35
		Arambagh	S/C	130	120%	156	Arambag-Kolaghat S/C	64	51	N	0.35	32	N	0.35
		Jeerat	S/C	162	120%	194	Jeerat-Subhasgram S/C	63	50	N	0.35	32	Y	0.5 to 0.6
22	Jeerat	Bahrapur	S/C	165	120%	198	Bahrapur-Sagardighi D/C	26	21	Y	0.5 to 0.6	13	Y	0.5 to 0.6
		Bakreswar TPS	S/C	162	120%	194	Arambag-Bakreswar S/C	130	104	N	0.35	65	N	0.35
		Subhasgram	S/C	63	120%	76	Subhasgram-Jeerat S/C	63	50	N	0.35	32	N	0.35
		Kolaghat TPS	S/C	134	120%	161	Kolaghat-Arambagh S/C	64	51	N	0.35	32	N	0.35
23	Subhasgram	Sagardighi	S/C	246	120%	295	Sagardighi-Bahrapur D/C	26	21	Y	0.5 to 0.6	13	Y	0.5 to 0.6
		Jeerat	S/C	63	120%	76	Jeerat-Subhasgram S/C	63	50	N	0.35	32	N	0.35
		Haldia TPS	D/C	90	150%	135	Haldia-Subhasgram other ckt	90	72	N	0.35	45	N	0.35
24	Kolaghat TPS	Arambagh	S/C	64	120%	77	Arambag-Kolaghat S/C	64	51	N	0.35	32	N	0.35
		Jeerat	S/C	134	120%	161	Jeerat-Subhasgram S/C	63	50	N	0.35	32	N	0.35

24	Kolaghat TPS	Kharagpur	S/C	98	120%	118	Kharagpur-Baripada S/C	98	78	N	0.35	49	N	0.35
		Chaibasa	S/C	240	120%	288	Chaibasa-Jamsedpur S/C	46	37	Y	0.5 to 0.6	23	Y	0.5 to 0.6
25	Kharagpur	Kolaghat TPS	S/C	98	120%	118	Kolaghat-Arambagh S/C	64	51	N	0.35	32	N	0.35
		Baripada	S/C	98	120%	118	Baripada-Kharagpur S/C	98	78	N	0.35	49	N	0.35
		Chaibasa	S/C	161	120%	193	Chaibasa-Jamsedpur S/C	46	37	N	0.35	23	Y	0.5 to 0.6
26	Baripada	Kharagpur	S/C	98	120%	118	Kharagpur-Baripada S/C	98	78	N	0.35	49	N	0.35
		N. Duburi	S/C	190	120%	228	N. Duburi-Meeramandali D/C	90	72	N	0.35	45	N	0.35
		Pandiabilli	S/C	302	120%	362	Pandiabilli-Mendasal D/C	28	22	Y	0.5 to 0.6	14	Y	0.5 to 0.6
		Keonjhar	S/C	156	120%	187	Keonjhar-Rengali S/C	100	80	N	0.35	50	N	0.35
		Jamsedpur	S/C	108	120%	130	Jamsedpur - Adhuniik D/C	1	0	Y	0.5 to 0.6	0	Y	0.5 to 0.6
		TISCO	S/C	140	120%	168	TISCO-Baripada S/C	33	26	Y	0.5 to 0.6	16	Y	0.5 to 0.6
27	N. Duburi	Baripada	S/C	190	120%	228	Baripada-Kharagpur S/C	98	78	N	0.35	49	N	0.35
		Pandiabilli	S/C	143	120%	172	Pandiabilli-Mendasal D/C	28	22	Y	0.5 to 0.6	14	Y	0.5 to 0.6
		Meramandali	D/C	90	150%	135	Meramandali-GMR S/C	8	6	Y	0.5 to 0.6	4	Y	0.5 to 0.6
28	Pandiabilli	Baripada	S/C	302	120%	362	Baripada-Kharagpur S/C	98	78	N	0.35	49	Y	0.5 to 0.6
		N. Duburi	S/C	143	120%	172	N. Duburi-Meeramandali D/C	90	72	N	0.35	45	N	0.35
		Mendasal	D/C	28	150%	42	Mendasal Pandiabilli D/C	28	22	N	0.35	14	N	0.35
29	Mendasal	Pandiabilli	D/C	28	150%	42	Pandiabilli-Mendasal D/C	28	22	N	0.35	14	N	0.35
		Meramandali	S/C	98	120%	118	Meramandali-GMR S/C	8	6	Y	0.5 to 0.6	4	Y	0.5 to 0.6
30	Meramandali	Mendasal	S/C	98	120%	118	Mendasal Pandiabilli D/C	28	22	N	0.35	14	Y	0.5 to 0.6
		Angul	S/C	25	120%	30	Angul-Meramandali S/C	19	15	N	0.35	9	N	0.35
		Angul	S/C	19	120%	22	Angul-Meramandali S/C	19	15	N	0.35	9	N	0.35
		TSTPS	S/C	51	120%	61	TSTPS-Rengali D/C	24	19	N	0.35	12	N	0.35
		JSPL	D/C	38	150%	57	JSPL-Meramandali Other ckt	38	30	N	0.35	19	N	0.35
		GMR	S/C	8	120%	10		999	799	N	0.35	500	N	0.35
		SEL	D/C	220	150%	330	SEL-Meramandali Other ckt	220	176	N	0.35	110	N	0.35
31	Angul	Meramandali	S/C	25	120%	30	Meramandali-GMR S/C	8	6	N	0.35	4	Y	0.5 to 0.6
		Meramandali	S/C	19	120%	22	Meramandali-GMR S/C	8	6	N	0.35	4	N	0.35
		Bolangir	S/C	196	120%	235	Bolangir-Angul S/C	196	157	N	0.35	98	N	0.35
		TSTPS	S/C	68	120%	82	TSTPS-Rengali D/C	24	19	N	0.35	12	Y	0.5 to 0.6
		JITPL	D/C	80	150%	120	JITPL-Angul Other Ckt	80	64	N	0.35	40	N	0.35
		GMR	D/C	31	150%	47	GMR-Angul Other Ckt	31	25	N	0.35	16	N	0.35
32	Bolangir	Angul	S/C	196	120%	235	Angul-Meramandali S/C	19	15	Y	0.5 to 0.6	9	Y	0.5 to 0.6
		Jeypore	S/C	287	120%	344	Jeypore-Indravati S/C	71	57	Y	0.5 to 0.6	36	Y	0.5 to 0.6
33	Jeypore	Bolangir	S/C	287	120%	344	Bolangir-Angul S/C	196	157	N	0.35	98	N	0.35
		Indravati	S/C	71	120%	85	Indravati-Indravati (O) S/C	4	3	Y	0.5 to 0.6	2	Y	0.5 to 0.6
		Gazuwaka	D/C	220	150%	330	Gazuwaka-Jeypore other ckt	220	176	N	0.35	110	N	0.35
34	Indravati	Jeypore	S/C	71	120%	85	Jeypore-Indravati S/C	71	57	N	0.35	36	N	0.35
		Rengali	S/C	356	120%	427	Rengali-TSTPS D/C	24	19	Y	0.5 to 0.6	12	Y	0.5 to 0.6
35	Indravati (o)	Indravati	S/C	4	120%	4		999	799	N	0.35	500	N	0.35
36	Rengali	Indravati	S/C	356	120%	427	Indravati-Indravati (O) S/C	4	3	Y	0.5 to 0.6	2	Y	0.5 to 0.6
		Keonjhar	S/C	100	120%	120	Keonjhar-Rengali S/C	100	80	N	0.35	50	N	0.35
		TSTPS	D/C	24	150%	36	TSTPS-Rengali D/C	24	19	N	0.35	12	N	0.35
37	Keonjhar	Baripada	S/C	156	120%	187	Baripada-Kharagpur S/C	98	78	N	0.35	49	N	0.35
		Rengali	S/C	100	120%	120	Rengali-TSTPS D/C	24	19	Y	0.5 to 0.6	12	Y	0.5 to 0.6
38	TSTPS	Meramandali	S/C	51	120%	61	Meramandali-GMR S/C	8	6	Y	0.5 to 0.6	4	Y	0.5 to 0.6
		Angul	S/C	68	120%	82	Angul-Meramandali S/C	19	15	N	0.35	9	Y	0.5 to 0.6
		Rengali	D/C	24	150%	36	Rengali-TSTPS D/C	24	19	N	0.35	12	N	0.35
		Rourkela	D/C	171	150%	257	Rourkela-Chaibasa D/C	131	105	N	0.35	66	Y	0.5 to 0.6
		TSTPS	D/C	171	150%	257	TSTPS-Rengali D/C	24	19	Y	0.5 to 0.6	12	Y	0.5 to 0.6
		Jharsuguda	D/C	145	150%	218	Jharsuguda-Rourkela S/C	63	50	Y	0.5 to 0.6	31	Y	0.5 to 0.6

39	Rourkela	SEL	S/C	135	120%	162	SEL-Rourkela S/C	135	108	N	0.35	68	N	0.35
		Chaibasa	S/C	131	120%	158	Chaibasa-Jamsedpur S/C	46	37	N	0.35	23	Y	0.5 to 0.6
		Jamsedpur	S/C	182	120%	218	Jamsedpur - Adhunik D/C	1	0	Y	0.5 to 0.6	0	Y	0.5 to 0.6
		Ranchi	D/C	144	150%	217	Ranchi-N.Ranchi D/C	79	63	Y	0.5 to 0.6	39	Y	0.5 to 0.6
40	Jharsuguda	Raigarh	S/C	139	120%	167	Raigarh-Raigarh Polling D/C	6	5	Y	0.5 to 0.6	3	Y	0.5 to 0.6
		Rourkela	D/C	145	150%	218	Rourkela-Chaibasa D/C	131	105	N	0.35	66	Y	0.5 to 0.6
		Raigarh	S/C	115	120%	137	Raigarh-Raigarh Polling D/C	6	5	Y	0.5 to 0.6	3	Y	0.5 to 0.6
41	IBEUL	IBEUL	S/C	63	120%	75	IBEUL-Raigrah S/C	63	50	N	0.35	31	N	0.35
		Jharsuguda	S/C	63	120%	75	Jharsuguda-Raigarh S/C	115	92	N	0.35	58	N	0.35
42	SEL	Raigarh	S/C	91	120%	109	Raigarh-Raigarh Polling D/C	6	5	Y	0.5 to 0.6	3	Y	0.5 to 0.6
		Raigarh	S/C	147	120%	176	Raigarh-Raigarh Polling D/C	6	5	Y	0.5 to 0.6	3	Y	0.5 to 0.6
43	Chaibasa	Rourkela	S/C	135	120%	162	Rourkela-Chaibasa S/C	131	105	N	0.35	66	N	0.35
		Kolaghat TPS	S/C	240	120%	288	Kolaghat-Arambagh S/C	64	51	N	0.35	32	Y	0.5 to 0.6
		Kharagpur	S/C	161	120%	193	Kharagpur-Baripada S/C	98	78	N	0.35	49	N	0.35
		Rourkela	S/C	131	120%	158	Rourkela-Chaibasa S/C	131	105	N	0.35	66	N	0.35
44	Jamsedpur	Jamsedpur	S/C	46	120%	55	Jamsedpur - Adhunik D/C	1	0	Y	0.5 to 0.6	0	Y	0.5 to 0.6
		Durgapur	S/C	177	120%	212	Durgapur-Bidhannagar D/C	11	9	Y	0.5 to 0.6	6	Y	0.5 to 0.6
		Baripada	S/C	108	120%	130	Baripada-Kharagpur S/C	98	78	N	0.35	49	N	0.35
		Rourkela	S/C	182	120%	218	Rourkela-Chaibasa D/C	131	105	N	0.35	66	N	0.35
		Chaibasa	S/C	46	120%	55	Chaibasa-Jamsedpur S/C	46	37	N	0.35	23	N	0.35
		Mejia B	S/C	168	120%	201	Mejia B- Maithon D/C	59	47	N	0.35	30	Y	0.5 to 0.6
		Maithon	S/C	153	120%	184	Maithon-MPL D/C	32	25	Y	0.5 to 0.6	16	Y	0.5 to 0.6
		DSTPS	D/C	157	150%	235	DSTPS-Jamsedpur D/C	69	55	Y	0.5 to 0.6	35	Y	0.5 to 0.6
45	Mejia B	TISCO	S/C	33	120%	39	TISCO-Baripada S/C	33	26	N	0.35	16	N	0.35
		Adhunik	D/C	1	150%	2	Jamsedpur - Adhunik D/C	1	0	Y	0.5 to 0.6	0	Y	0.5 to 0.6
		Jamsedpur	S/C	168	120%	201	Jamsedpur - Adhunik D/C	1	0	Y	0.5 to 0.6	0	Y	0.5 to 0.6
46	Maithon	Maithon	S/C	84	120%	100	Maithon-MPL D/C	32	25	N	0.35	16	Y	0.5 to 0.6
		Maithon	D/C	59	150%	89	Maithon-MPL D/C	32	25	Y	0.5 to 0.6	16	Y	0.5 to 0.6
		Gaya	D/C	276	150%	414	Gaya-Chandwa D/C	117	94	Y	0.5 to 0.6	59	Y	0.5 to 0.6
		Kahalgaon	D/C	172	150%	258	Kahalgaon-Bankad/C	48	38	Y	0.5 to 0.6	24	Y	0.5 to 0.6
		Durgapur	D/C	71	150%	106	Durgapur-Bidhannagar D/C	11	9	Y	0.5 to 0.6	6	Y	0.5 to 0.6
		Jamsedpur	S/C	153	120%	184	Jamsedpur - Adhunik D/C	1	0	Y	0.5 to 0.6	0	Y	0.5 to 0.6
		Mejia B	S/C	84	120%	100	Mejia B- Maithon D/C	59	47	N	0.35	30	N	0.35
		Mejia B	D/C	59	150%	89	Mejia B- Maithon D/C	59	47	N	0.35	30	N	0.35
47	MPL	MPL	D/C	32	150%	47	MPL-Maithon D/C	32	25	N	0.35	16	N	0.35
		Raghunatpur	S/C	55	120%	65	Raghunatpur-Maithon S/C	55	44	N	0.35	27	N	0.35
		Ranchi	S/C	200	120%	240	Ranchi-N.Ranchi D/C	79	63	N	0.35	39	Y	0.5 to 0.6
48	DSTPS	Maithon	D/C	32	150%	47	Maithon-MPL D/C	32	25	N	0.35	16	N	0.35
		Ranchi	D/C	188	150%	281	Ranchi-N.Ranchi D/C	79	63	Y	0.5 to 0.6	39	Y	0.5 to 0.6
49	Raghunathpur	Jamsedpur	D/C	157	150%	235	Jamsedpur - Adhunik D/C	1	0	Y	0.5 to 0.6	0	Y	0.5 to 0.6
		Raghunatpur	D/C	69	150%	104	Raghunatpur-Maithon S/C	55	44	N	0.35	27	Y	0.5 to 0.6
		Maithon	S/C	55	120%	65	Maithon-MPL D/C	32	25	N	0.35	16	N	0.35
50	Ranchi	DSTPS	D/C	69	150%	104	DSTPS-Jamsedpur D/C	69	55	N	0.35	35	N	0.35
		Ranchi	S/C	166	120%	199	Ranchi-N.Ranchi D/C	79	63	N	0.35	39	N	0.35
		Rourkela	D/C	144	150%	217	Rourkela-Chaibasa D/C	131	105	N	0.35	66	Y	0.5 to 0.6
		Maithon	S/C	200	120%	240	Maithon-MPL D/C	32	25	Y	0.5 to 0.6	16	Y	0.5 to 0.6
		MPL	D/C	188	150%	281	MPL-Maithon D/C	32	25	Y	0.5 to 0.6	16	Y	0.5 to 0.6
		Raghunatpur	S/C	166	120%	199	Raghunatpur-Maithon S/C	55	44	N	0.35	27	Y	0.5 to 0.6
		N. Ranchi	D/C	79	150%	118	N. Ranchi-Chandwa D/C	68	54	N	0.35	34	Y	0.5 to 0.6
	Ranchi	N. Ranchi	D/C	79	150%	118	N. Ranchi-Chandwa D/C	68	54	N	0.35	34	Y	0.5 to 0.6
		Sipat	D/C	405	150%	608	Sipat-Korba S/C	100	80	Y	0.5 to 0.6	50	Y	0.5 to 0.6
		Ranchi	D/C	79	150%	118	Ranchi-N.Ranchi D/C	79	63	N	0.35	39	Y	0.5 to 0.6

51	N. Ranchi	Ranchi	D/C	79	150%	118	Ranchi-N.Ranchi D/C	79	63	N	0.35	39	N	0.35
		Chandwa	D/C	68	150%	102	Chandwa-N.Ranchi D/C	68	54	N	0.35	34	N	0.35
52	Chandwa	Gaya	D/C	117	150%	176	Gaya-Chandwa D/C	117	94	N	0.35	59	N	0.35
		N. Ranchi	D/C	68	150%	102	N. Ranchi-Chandwa D/C	68	54	N	0.35	34	N	0.35
53	Koderma	Gaya	D/C	125	150%	188	Gaya-Chandwa D/C	117	94	N	0.35	59	Y	0.5 to 0.6
		Biharsariff	D/C	111	150%	166	Biharsaiff-Lakhisarai D/C	89	71	N	0.35	45	Y	0.5 to 0.6
		Bokaro	D/C	100	150%	150	Koderma-Bokaro D/C	100	80	N	0.35	50	N	0.35
54	Bokaro	Koderma	D/C	100	150%	150	Koderma-Bokaro D/C	100	80	N	0.35	50	N	0.35
55	Rangpo	Binaguri	D/C	110	150%	165	Binaguri-Kishanhanj D/C	98	78	N	0.35	49	Y	0.5 to 0.6
		Teesta V	D/C	12	150%	18	Rangpo-Teesta D/C	12	10	N	0.35	6	N	0.35
56	TISCO	Baripada	S/C	140	120%	168	Baripada-Kharagpur S/C	98	78	N	0.35	49	N	0.35
		Jamsedpur	S/C	33	120%	39	Jamsedpur - Adhunik D/C	1	0	Y	0.5 to 0.6	0	Y	0.5 to 0.6
57	Teesta V	Rangpo	D/C	12	150%	18	Rangpo-Teesta D/C	12	10	N	0.35	6	N	0.35
58	GMR	Angul	D/C	31	150%	47	Angul-Meramandali S/C	19	15	Y	0.5 to 0.6	10	Y	0.5 to 0.6
59	GMR(O)	Meramandali	S/C	8	120%	10	Meramandali-Angul S/C	19	15	N	0.35	10	N	0.35
60	JITPL	Angul	D/C	80	150%	120	Angul-Meramandali S/C	19	15	Y	0.5 to 0.6	10	Y	0.5 to 0.6

Annexure-C8

Name of the substation	NAME OF LINE	OVERVOLTAGE % SETTING					REMARK
		LOCAL END(STAGE-I)			REMOTE END(STAGE-I)		
		VOLTAGE GARDIENT(% setting)	TIME DELAY(sec)	Drop Off to Pickup ratio	VOLTAGE GARDIENT(% setting)	TIME DELAY(sec)	
Binaguri	400KV BINAGURI-RANGPO-I	110	5		112	7	
	400KV BINAGURI-RANGPO-II	112	5		112	7	
	400KV BINAGURI-TALA-I	110	5		105	5	
	400KV BINAGURI-TALA-II	112	5		105	5	
	400KV BINAGURI-MALABASE-III	110	5		105	5	
	400KV BINAGURI-TALA-IV	112	5		105	5	
	400 KV BINAGURI-PURNEA- I	110	5		112	5	
	400 KV BINAGURI-PURNEA- II	112	5		110	5	
	400 KV BINAGURI-KISHANGANJ- I	110	5		112	5	Need to be updated after LILO at Kishanganj
	400 KV BINAGURI-KISHANGANJ- II	112	5		110	7	
	400KV BINAGURI-BONGAIGAON-I	110	5		OTHER REGION		May be submitted by ER - II, Powergrid
	400KV BINAGURI-BONGAIGAON-II	110	6				
	400KV BINAGURI-BONGAIGAON-III	110	5				
400KV BINAGURI-BONGAIGAON-IV	110	6					
Kishanganj	400 KV KISHANGANJ-PURNEA-I						
	400 KV KISHANGANJ-PURNEA-II						
	400 KV KISHANGANJ-BINAGURI-I						
	400 KV KISHANGANJ-BINAGURI-II						
	400 KV KISHANGANJ-PATNA-I						
	400 KV KISHANGANJ-PATNA-II						
Rangpo	400KV RANGPO-TEESTA-I	112	7		110	7	
	400KV RANGPO-TEESTA-II	112	7		112	5	
	400KV RANGPO-BINAGURI-I	112	7		110	5	
	400KV RANGPO-BINAGURI-II	112	7		112	5	
Tala	400KV TALA-BINAGURI-I	105	5		110	5	
	400KV TALA-BINAGURI-II	105	5		112	5	
	400KV TALA-MALABASE-III	105	5		110	5	
	400KV TALA-BINAGURI-IV	105	5		112	5	
Teesta	400KV TEESTA-RANGPO-I	110	7		112	7	
	400KV TEESTA-RANGPO-II	112	5		112	7	
PURNEA	400 KV PURNEA - MALDA - I	110	7		110	5	
	400 KV PURNEA - MALDA - II	112	5		110	6	
	400 KV PURNEA - BINAGURI - I	112	5		110	5	
	400 KV PURNEA - BINAGURI - II	110	5		112	5	
	400 KV PURNEA - KISHANGANJ - I	112	5		110	5	Need to be updated after LILO at Kishanganj
	400 KV PURNEA - KISHANGANJ - II	112	5		112	5	
	400 KV PURNEA-MUZAFFARPUR-I	110	7		110	7	
	400 KV PURNEA-MUZAFFARPUR-II	112	7		112	7	
	400 KV PURNEA-BIHARSHARIFF-I	110	5		110	5	
400 KV PURNEA-BIHARSHARIFF-II	110	7		110	7		
MALDA	400 KV MALDA - PURNEA - I	110	5		110	7	
	400 KV MALDA - PURNEA - II	110	6		112	5	
	400 KV MALDA - FARAKKA - I	110	5		110	5	
	400 KV MALDA - FARAKKA - II	110	6		110	5	
	400 KV FSTPP-MALDA-I	110	5		110	5	
	400 KV FSTPP-MALDA-II	110	5		110	6	
	400 KV FSTPP-DURGAPUR-I	112	7		110	5	

FARAKKA	400 KV FSTPP-DURGAPUR-II	110	5		112	5		
	400 KV FSTPP-KhSTPP-I	110	5		110	5		
	400 KV FSTPP-KhSTPP-II	112	5		112	5		
	400 KV FSTPP-KhSTPP-III	110	7		110	7		
	400 KV FSTPP-KhSTPP-IV	112	7		112	7		
	400 KV FSTPP-BEHRAMPUR	110	12		110	6		
	400 KV FSTPP-SAGARDIGHI	112	7		140	0.1		
Behrampur	400 KV BEHRAMPUR-BHERAMARA -I	110	5		110	4		
	400 KV BEHRAMPUR-BHERAMARA -II	110	10		110	5		
	400 KV BEHRAMPUR - FARAKKA	110	6		110	12		
	400KV BERHAMPURE-SAGARDIGHI-I	110	5		110	5		
	400KV BERHAMPURE-SAGARDIGHI-II	110	6		110	7		
	400 KV BEHRAMPUR - JEERAT	110	7		110	7		
	400KV JEERAT-SUBHASHGRAM	112	5		112	5		
Jeerat	400 KV JERAT - BERHAMPUR	110	7		110	7		
	400 KV Jeerat-Bakreswar	110	5		110	5		
	400 KV Jeerat-Kolaghat	NOT INSTALLED AT BOTH ENDS						Present status may be updated
	400 KV SUBHASHSHGRAM-SAGARDIGHI	112	5		112	5		
Subhashgram	400KV SUBHASHGRAM-HALDIA-I	110	5		110	3		
	400KV SUBHASHGRAM-HALDIA-II	110	6		110	5		
	400 KV SUBHASHGRAM-JEERAT	112	5		112	5		
	400KV HALDIA-SUBHASHGRAM-I	110	3		110	5		
HALDIA	400KV HALDIA-SUBHASHGRAM-II	110	5		110	6		
	400 KV SAGARDIGHI - FARAKKA	140	0.1		112	7		
SAGARDIGHI	400 KV SAGARDIGHI - DURGAPUR-I	110	5		110	5		
	400 KV SAGARDIGHI - DURGAPUR-II	110	6		110	6		
	400KV SAGARDIGHI-BERHAMPURE-I	110	5		110	5		
	400KV SAGARDIGHI-BERHAMPURE-II	110	7		110	6		
	400 KV SAGARDIGHI - SUBHASHGRAM	112	5		112	5		
	400 KV DURGAPUR - SAGARDIGHI-I	110	5		110	5		
	400 KV DURGAPUR - SAGARDIGHI-II	110	6		110	6		
Durgapur	400 KV DURGAPUR-FSTPP-I	110	5		112	7		
	400 KV DURGAPUR-FSTPP-II	112	5		110	5		
	400 KV DURGAPUR-MAITHON-I	110	5		110	5		
	400 KV DURGAPUR-MAITHON-II	110	6		110	6		
	400 KV DURGAPUR-JAMSHEDPUR	110	5		112	5		
	400 KV DURGAPUR - BIDHANNAGAR-I	110	5		110	5		
	400 KV DURGAPUR - BIDHANNAGAR-II	110	5		110	5		
	400 KV BIDHANNAGAR-PPSP-I	110	5		110	5		
	400 KV BIDHANNAGAR-PPSP-II	110	5		110	5		
	400 KV BIDHANNAGAR - DURGAPUR-I	110	5		110	5		
PPSP	400 KV BIDHANNAGAR - DURGAPUR-II	110	5		110	5		
	400 KV PPSP-BIDHAN NAGAR-I	110	5		110	5		
	400 KV PPSP-BIDHAN NAGAR-II	110	5		110	5		
	400 KV PPSP-ARAMBAG-I	110	5		110	5		
Arambag	400 KV PPSP-ARAMBAG-II	110	5		110	5		
	400 KVARAMBAG-PPSP-I	110	5		110	5		
	400 KV ARAMBAG-PPSP-II	110	5		110	5		
	400 KV ARAMBAG-KOLAGHAT	110	5		NOT INSTALLED AT KOLAGHAT END		Present status may be updated	
	400 KV ARAMBAG-BAKRESWAR	110	5		110	5		
BAKRESWAR	400 KV ARAMBAG-BIDHANNAGAR	110	5		110	5		
	400 KV BAKRESWAR-JEERAT	110	5		110	5		
	400 KV BAKRESWAR-ARAMBAG	110	5		110	5		

KOLAGHAT	400 KV KOLAGHAT-JEERAT	NOT INSTALLED AT BOTH ENDS				Present status may be updated
	400 KV KOLAGHAT-ARAMBAG	NOT INSTALLED TA KOLAGHAT END		110	5	Present status may be updated
	400 KV KOLAGHAT-KHARAGPUR-I	110	5	110	5	
	401 KV KOLAGHAT-CHAIBASA-I	110	5	110	5	Need to be updated after Chaibasa connectivity
KHARAGPUR	400 KV KHARAGPUR-KOLAGHAT-I	110	5	110	5	
	400KV KHARAGPUR-CHAIBASA-I	110	5	110	5	Need to be updated after Chaibasa connectivity
BARIPADA	400KV KHARAGPUR-BARIPADA	110	5	112	7	
	400 KV BARIPADA-KEONJHAR	110	3	110	5	
	400 KV BARIPADA- TISCO(JAMSHEDPUR)	111	5	110	4	
	400 KV BARIPADA-N. DUBURI -I	112	6	110	5	Needs to be upgated after LILO at N. Duburi
	400 KV BARIPADA-PANDIABILLI-I	112	6	110	5	Needs to be updated after LILO at Pandiabilli
Jamshedpur	400 KV BARIPADA-KHARAGPUR	112	7	110	5	
	400 KV BARIPADA-JAMSHEDPUR	111	5	110	4	
	400 KV JAMSHEDPUR-CHAIBASA - I	112	5	112	5	
	400 KV JAMSHEDPUR-CHAIBASA- II	110	7	110	6	
	400 KV JAMSHEDPUR - MEJIA	112	5	117	2.5	
	400 KV JAMSHEDPUR - DSTPS(ANDAL)-I	110	5	117	2.5	
	400 KV JAMSHEDPUR - DSTPS(ANDAL)-II	112	5	117	2.5	
	400KV JAMSHEDPUR - APNRL-I	110	5	115	5	
	400KV JAMSHEDPUR - APNRL-II	110	5	115	5	
	400 KV JAMSHEDPUR - DURGAPUR	112	5	110	5	
	400 KV JAMSHEDPUR - TISCO	112	7	112	7	
	400 KV JAMSHEDPUR-MAITHON	110	5	110	5	
CHAIBASA	400 KV JAMSHEDPUR-BARIPADA	110	4	111	5	
	400KV CHAIBASA-JAMSHEDPUR-I	112	5	112	5	
	400KV CHAIBASA-JAMSHEDPUR-II	110	6	110	7	
	400KV CHAIBASA-KHARAGPUR-II					Need to be updated after Chaibasa connectivity
	400KV CHAIBASA-KOLAGHAT-II					Need to be updated after Chaibasa connectivity
APNRL	400KV CHAIBASA-ROURKELA-I	112	7	110	5	
	400KV CHAIBASA-ROURKELA-II			110	6	
TISCO	400 KV APNRL-JAMSHEDPUR-I	115	5	110	5	
	400 KV APNRL-JAMSHEDPUR -II	115	5	110	5	
Maithon	400 KV TISCO-JAMSHEDPUR	112	7	112	7	
	400 KV TISCO-BIRPADA	110	4	111	5	
Ranchi	400 KV MAITHON-RANCHI	112	5	112	5	
	400 KV MAITHON-KAHALGAON-I	110	5	112	5	
	400 KV MAITHON-KAHALGAON-II	110	6	110	5	
	400 KV MAITHON -MAITHON RB-I	110	5	110	7	
	400 KV MAITHON -MAITHON RB-II	112	5	112	7	
	400 KV MAITHON -GAYA - I	110	5	110	5	
	400 KV MAITHON -GAYA-II	110	6	110	5	
	400 KV MAITHON-JAMSHEDPUR	110	5	110	5	
	400 KV MAITHON -MEJIA- I	110	5	117	2.5	
	400 KV MAITHON -MEJIA- II	112	5	117	2.5	
	401 KV MAITHON -MEJIA- III	110	5	117	2.5	
	400 KV MAITHON - DURGAPURR - I	110	5	110	5	
	400 KV MAITHON - DURGAPURR - II	110	6	110	6	
	400 KV MAITHON -RAGHUNATHPUR	112	6	113	5	
	400 KV RANCHI-MAITHON	112	5	112	5	
	400 KV RANCHI-NEW RANCHI-I	110	5	110	5	
400 KV RANCHI-NEW RANCHI-II	110	5	110	5		
400 KV RANCHI-NEW RANCHI-III	110	5	110	5		
400 KV RANCHI-NEW RANCHI-IV	110	5	110	5		
400 KV RANCHI-RAGHUNATHPUR	110	5	113	5		
400 KV RANCHI-MAITHON RB-I	112	7	112	7		
400 KV RANCHI-MAITHON RB-II	110	7	110	7		

	400 KV RANCHI - SIPAT - I	110	7		OTHER REGION			May be submitted by ER - I, Powergrid
	400 KV RANCHI - SIPAT - II	112	5					
	400 KV RANCHI-ROURKELA- I	110	5		110	5		
	400 KV RANCHI-ROURKELA - II	112	7		110	6		
765/400 KV NEW RANCHI S/S	400 KV NEW RANCHI- RANCHI-I	110	5		110	5		
	400 KV NEW RANCHI- RANCHI-II	110	5		110	5		
	400 KV NEW RANCHI- RANCHI-III	110	5		110	5		
	400 KV NEW RANCHI- RANCHI-IV	110	5		110	5		
	400 KV NEW RANCHI- CHANDWA-I							
	400 KV NEW RANCHI- CHANDWA-II							
	765 KV KV NEW RANCHI-DHARMJAYGARH-I	107	5		OTHER REGION			May be submitted by ER - I, Powergrid
	765 KV KV NEW RANCHI-DHARMJAYGARH-II							
CHANDWA	400 KV CHANDWA-N.RANCHI-I							
	400 KV CHANDWA-N.RANCHI-II							
	400 KV CHANDWA-GAYA-I							
	400 KV CHANDWA-GAYA-II							
MAITHON RIGHT BANK	400 KV MAITHON RB-RANCHI-I	112	7		112	7		
	400 KV MAITHON RB-RANCHI-II	110	7		110	7		
	400 KV MAITHON RB-MAITHON-I	110	7		110	5		
	400 KV MAITHON RB-MAITHON-II	112	7		112	5		
DSTPS	400 KV DSTPS-JAMSHEDPUR-I	117	2.5		110	5		
	400 KV DSTPS-JAMSHEDPUR-II	117	2.5		112	5		
	400 KV DSTPS-RAGHUNATHPUR-I	117	2.5		113	5		
	400 KV DSTPS-RAGHUNATHPUR-II	117	2.5		113	5		
KODERMA	400 KV KODERMA-GAYA-I	113	5		110	5		
	400 KV KODERMA-GAYA-II	113	5		110	5		
	400 KV KODERMA-BIHARSHARIFF-I	113	5		112	7		
	400 KV KODERMA-BIHARSHARIFF-II	113	5		110	5		
	400KV KODERMA-BOKARO-A-I	113	5		110	6		
	400KV KODERMA-BOKARO-A-II	113	5		110	6		
BOKARO-A	400KV BOKARO-A-KODERMA-I	110	6		113	5		
	400KV BOKARO-A-KODERMA-II	110	6		113	5		
Mejia	400 KV MEJIA-MAITHON -I	117	2.5		110	5		
	400 KV MEJIA-MAITHON -II	117	2.5		112	5		
	400 KV MEJIA-MAITHON -III	117	2.5		110	5		
	400 KV MEJIA-JAMSHEDPUR	117	2.5		112	5		
RAGHUNATHPUR	400 KV RAGHUNATHPUR-MAITHON	113	5		112	6		
	400 KV RAGHUNATHPUR-RANCHI	113	5		110	5		
	400 KV RAGHUNATHPUR-DSTPS-I	113	5		117	2.5		
	400 KV RAGHUNATHPUR-DSTPS-II	113	5		117	2.5		
MENDHASAL	400 KV MENDHASAL-PANDIABILLI-I	110	5		112	6		Needs to be updated after LILO at Pandiabilli
	400 KV MENDHASAL-PANDIABILLI-II	110	5		112	6		Needs to be updated after LILO at Pandiabilli
	400 KV MENDHASAL-MEERAMUNDALI	110	5		110	5		
PANDIABILLI	400 KV PANDIABILLI-MENDASAL-I							
	400 KV PANDIABILLI-MENDASAL-II							
	400 KV PANDIABILLI-N.DUBURI							
	400 KV PANDIABILLI - BARIPADA							
N. DUBURI	400 KV N.DUBURI-PANDIABILLI							
	400 KV N.DUBURI-BARIPADA							
	400 KV N.DUBURI-MERAMANDALI-I							
	400 KV N.DUBURI-MERAMANDALI-II							
	400 KV MEERAMUNDALI-TALCHER	110	5		110	5		
	400 KV MEERAMUNDALI-ANGUL-II	112	5		110	5		
	400 KV MEERAMUNDALI-JINDAL-I	110	5		110	5		
	400 KV MEERAMUNDALI-JINDAL-II	110	5		110	5		
	400 KV MEERAMUNDALI-ANGUL-I	112	5		110	5		

MEERAMUNDALI	400 KV MEERAMUNDALI-MENDHASAL	110	5		110	5		
	400KV MERAMUNDALI-GMR	110	5		110	5		
	400 KV MERAMUNDALI-STERLITE -I							
	400 KV MERAMUNDALI-STERLITE -II							
	400 KV MERAMUNDALI-N.DUBURI -I							
	400 KV MERAMUNDALI-N.DUBURI -I							
JINDAL	400 KV JINDAL-MEERAMUNDALI-I	110	5		110	5		
	400 KV JINDAL-MEERAMUNDALI-II	110	5		110	5		
GMR	400 KV GMR-ANGUL-I	110	2		110	5		
	400 KV GMR-ANGUL-II	110	2		110	6		
	400KV GMR-MERAMUNDALI	110	5		110	5		
ANGUL	400 KV ANGUL-MEERAMUNDALI-I	110	5		112	5		
	400KV ANGUL-BOLANGIR	110	5		110	5		
	400KV ANGUL-TSTPP	110	5		110	5		
	400 KV ANGUL-MERAMUNDALI-II	110	5		112	5		
	400 KV ANGUL-JITPL-II	110	5		110	5		
	400 KV ANGUL-JITPL-I	110	5		110	5		
	400KV ANGUL-GMR-I	110	5		110	2		
	400KV ANGUL-GMR-II	110	6		110	2		
	765kV Angul-Jharsuguda-I	110	4		110	4		
	765kV Angul-Jharsuguda-II	110	4		110	4		
JITPL	400 KV JITPL-ANGUL-I	110	5		110	5		
	400 KV JITPL-ANGUL-II	110	5		110	5		
BOLANGIR	400 KV BOLANGIR-ANGUL	110	5		110	5		
	400 KV BOLANGIR-JEYPORE	112	5		112	5		
Jeypore	400 KV JEYPORE-BOLANGIR	112	5		112	5		
	400 KV JEYPORE-GAZUWAKA-I	110	5		110	9		
	400 KV JEYPORE-GAZUWAKA-II	110	10		110	10		
	400KV JEYPORE-INDRAVATI	112	5		110	5		
INDRAVATI(PG)	400 KV INDRAVATI-JEYPORE	110	5		112	5		
	400 KV INDRAVATI-INDRAVATI	115	5		115	5		
	400 KV INDRAVATI-RENGALI	113	5		110	5		
INDRAVATI(GR)	400 KV INDRAVATI(GR)-INDRAVATI(PG)	115	5		115	5		
Rengali	400 KV RENGALI-INDRAVATI(PG)	110	5		113	5		
	400 KV RENGALI-KEONJHAR	110	5		110	5		
	400 KV RENGALI-TALCHER-I	110	5		110	5		
	400 KV RENGALI-TALCHER-II	110	6		112	5		
KEONJHOR	400 KV KEONJHAR-RENGALI	110	5		110	5		
	400 KV KEONJHAR-BIRPADA	110	3		110	5		
Talcher	400 KV Talcher-Rourkela-I	110	5		110	5		
	400 KV Talcher-Rourkela-II	112	5		110	6		
	400 KV Talcher-Rengali-I	110	5		110	5		
	400 KV Talcher-Rengali-II	112	5		110	6		
	400 KV Talcher-MERAMUNDALI	110	5		110	5		
	400 KV Talcher-ANGUL	110	5		110	5		
Rourkela	400 KV ROURKELLA-JHARSHUGUDA-I	110	5		110	10		
	400 KV ROURKELLA-JHARSHUGUDA-II	110	6		110	6		
	400 KV ROURKELLA-RAIGARH	112	5		OTHER REGION			May be submitted by Odisha Project, Powergrid
	400 KV ROURKELLA-STERLITE-II	110	6		115	5		
	400 KV ROURKELLA-TALCHER-I	110	5		110	5		
	400 KV ROURKELLA-TALCHER-II	110	6		112	5		
	400 KV ROURKELLA-CHAIBASA-I	110	5		112	7		
	400 KV ROURKELLA-CHAIBASA-II	110	6					
	400 KV ROURKELLA-RANCHI-I	110	5		110	5		
	400 KV ROURKELLA-RANCHI-II	110	6		112	7		
	400 KV STERLITE - ROURKELA - II	115	5		110	6		

STERLITE	400 KV STERLITE - RAIGARH - II	115	5		OTHER REGION		May be submitted by Odisha Project, Powergrid
	400 KV STERLITE-MERAMANDALI-I						
	400 KV STERLITE-MERAMANDALI-II						
Jharshuguda	400KV JHSUGUDA-ROURKELA-I	110	10		110	5	
	400KV JHSUGUDA-ROURKELA-II	110	6		110	6	
	400 KV JHARSHUGUDA-IBEUL	110	10		110	5	
	765kV Jharsuguda-ANGUL-I	110	4		110	4	
	765kV Jharsuguda-ANGUL-II	110	4		110	4	
	400 KV JHARSHUGUDA-RAIGARH -II	110	6		111	7	
Jharsguda 765KV S/s	765kv Jharsuguda-Dharmjaygarh-I	108	5		OTHER REGION		May be submitted by Odisha Project, Powergrid
	765kv Jharsuguda-Dharmjaygarh-II	108	7		OTHER REGION		May be submitted by Odisha Project, Powergrid
	765kV Jharsuguda-Angul-I	110	4		110	4	
	765kV Jharsuguda-Angul-II	110	4		110	4	
IBEUL	400kV IBEUL-Raigarh	110	5		OTHER REGION		May be submitted by Odisha Project, Powergrid
	400kV IBEUL-Jharsuguda	110	5		110	10	
APNRL	400 KV APNRL-JAMSHEDPUR-I	115	5		110	5	
	400 KV APNRL-JAMSHEDPUR -II	115	5		110	5	
BIHARSHARIFF	400 KV BIHARSHARIFF-BANKA-I	112	7		112	7	
	400 KV BIHARSHARIFF-BANKA-II	110	6		110	6	
	400 KV BIHARSHARIFF - PUSAULI - I	110	5		110	5	
	400 KV BIHARSHARIFF - PUSAULI - II	112	5		112	5	
	400 KV BIHARSHARIFF - VARANASI- I	112	7		112	7	
	400 KV BIHARSHARIFF - VARANASI- II	110	7		110	7	
	400 KV BIHARSHARIFF - BALIA - I	110	5		OTHER REGION		May be submitted by ER-I, Powergrid
	400 KV BIHARSHARIFF - BALIA - II	112	5		OTHER REGION		May be submitted by ER-I, Powergrid
	400 KV BIHARSHARIFF-KODERMA-I	112	7		113	5	
	400 KV BIHARSHARIFF-KODERMA-II	110	5		113	5	
	400 KV BIHARSHARIFF-PURNEA-I	110	5		110	5	
	400 KV BIHARSHARIFF-PURNEA-II	110	7		110	7	
	400 KV BIHARSHARIFF-LAKHISARAI-I	110	7		110	5	
	400 KV BIHARSHARIFF-LAKHISARAI-II	112	5		110	5	
	400 KV BIHARSHARIFF-MUZAFFARPUR-I	110	5		110	5	
400 KV BIHARSHARIFF-MUZAFFARPUR-II	112	5		112	5		
Kahalgaon	400 KV KhSTPP-BANKA -I	110	6		110	6	
	400 KV KhSTPP-BANKA - II	112	7		112	7	
	400 KV KhSTPP - LAKHISARAI- I	110	7		110	7	
	400 KV KhSTPP - LAKHISARAI- II	112	5		112	5	
	400 KV KhSTPP-MAITHON -I	112	5		110	5	
	400 KV KhSTPP-MAITHON -II	110	5		110	6	
	400 KV KhSTPP-BARH - I	112	6		112	6	
	400 KV KhSTPP-BARH- II	112	6		112	6	
	400 KV KHSTPP-FSTPP-I	110	5		110	5	
	400 KV KHSTPP-FSTPP-II	112	5		112	5	
	400 KV KHSTPP-FSTPP-III	110	7		110	7	
	400 KV KHSTPP-FSTPP-IV	112	7		112	7	
Barh	400 KV BARH-KAHALGAON-I	112	6		112	6	
	400 KV BARH-KAHALGAON-II	112	6		112	6	
	400 KV BARH - PATNA-I	112	6		112	6	
	400 KV BARH - PATNA-II	112	7		112	7	
	400 KV BARH - PATNA-III	110	4		110	4	
	400 KV BARH - PATNA-IV	110	5		110	5	
	400 KV BARH - GORAKHPUR-I						
	400 KV BARH - GORAKHPUR-II						
PATNA-BARH	400 KV PATNA-BARH-I	112	6		112	6	
	400 KV PATNA-BARH-II	112	7		112	7	
	400 KV PATNA-BARH-III	110	4		110	4	

PATNA	400 KV PATNA-BARH-IV	110	5		110	5		
	400 KV PATNA-KISHANGANJ-I							
	400 KV PATNA-KISHANGANJ-II							
	400 KV PATNA - BALIA - I	110	4		OTHER REGION			May be submitted by ER-I, Powergrid
	400 KV PATNA - BALIA - II	110	5					
400 KV PATNA - BALIA - III	112	6						
400 KV PATNA - BALIA - IV	112	7						
Sasaram	765KV SASARAM-FATEHPUR	108	5		108	5		
	400 KV PUSAULI - VARANASI	112	5		OTHER REGION			May be submitted by ER-I, Powergrid
	400 KV PUSAULI - ALLAHABAD	112	7					
	400 KV PASAULI-BIHARSHARIFF-I	110	5		110	5		
	400 KV PASAULI-BIHARSHARIFF-II	112	5		112	5		
	400KV PUSAULI-NABINAGAR-I	110	5					
Gaya	400KV PUSAULI-NABINAGAR-II	110	6					
	400 KV GAYA-KODERMA-I	110	5		113	5		
	400KV GAYA-KODERMA-II	110	5		113	5		
	400KV GAYA-MAITHON-I	110	5		110	5		
	400KV GAYA-MAITHON-II	110	5		110	6		
	765 KV GAYA-VARANASI-I							
BANKA	765 KV GAYA-VARANASI-II							
	765 KV GAYA-BALIA	110	5		OTHER REGION			May be submitted by ER-I, Powergrid
	400 KV BANKA-BIHARSHARIFF-I	112	7					
	400 KV BANKA-BIHARSHARIFF-II	110	6		112	7		
	400 KV BANKA-KAHALGAON-I	110	6		110	6		
	400 KV BANKA-KAHALGAON-II	112	7		112	7		
Muzaffarpur	400 KV MUZAFFARPUR - NEW PURNEA - I	110	7		110	7		
	400 KV MUZAFFARPUR - NEW PURNEA - II	112	7		112	7		
	400 KV MUZAFFARPUR - GORAKHPUR - I	110	7		OTHER REGION			May be submitted by ER-I, Powergrid
	400 KV MUZAFFARPUR - GORAKHPUR - II	112	5					
	400 KV MUZAFFARPUR - BIHARSHARIFF - I	110	5		110	5		
	400 KV MUZAFFARPUR - BIHARSHARIFF - II	112	5		112	5		
LAKHISARAI	400 KV LAKHISARI-BIHARSHARIFF-I	110	5		110	7		
	400 KV LAKHISARI-BIHARSHARIFF-II	110	5		112	5		
	400 KV LAKHISARAI-KAHALGAON-I	110	5		110	7		
	400 KV LAKHISARI-KAHALGAON-II	110	5		112	5		

Annexure-D1

S.NO	LINE NAME	TRIP DATE	TRIP TIME	RESTORATION DATE	RESTORATION TIME	Reason	Fault Clearance time in msec	Relay Indication LOCAL END	Relay Indication REMOTE END	Auto Recloser status	DR/EL received within 24 Hrs	DR/EL received after 24 Hrs	Remarks
Fault clearing time is violating protection standard (As per PMU data)													
1	220 KV PATRATU-TENUGHAT	13.01.17	03:52	13.01.17	04:12	B-N FAULT	350 ms	Master trip relay	B-N, Z-IV, Fault clearing time 386 ms	--	No	Yes	Unit #10 at Patratu also tripped due to problem in UAT at the time of disturbance
2	220KV TARKERA-ROURKELA-II	27.01.17	11:26	27.01.17	16:54	B-N FAULT	360 ms approx	B-N, Z-I, 5.06 km from Tarkera	B-N, Z-II	No autoreclose operation observed in PMU data	No	Yes	Carrier not in service
Multiple tripping at same time													
1	400 KV ARAMBAG PPSP	10.01.17	11:12	10.01.17	12:09	SPURIOUS TRIPPING	--	DT Received	Information yet to be received	--	No	No	Fault not observed in PMU data
2	400 KV ARAMBAG NEW RANCHI			10.01.17	12:02		--	DT Received	Information yet to be received	--	No	No	
Fault Not observed in PMU data													
1	400 KV MERAMUNDALI NEW DUBURI - II	01.01.17	11:21	01.01.17	12:31	SPURIOUS TRIPPING	--	Did not trip	Information yet to be received	--	--	No	
2	400 KV RTPS RANCHI	11.01.17	18:56	11.01.17	19:14	SPURIOUS TRIPPING	--	Did not trip	DT Received	--	--	No	
3	400 KV NEW RANCHI PPSP	12.01.17	14:40	12.01.17	16:17	SPURIOUS TRIPPING	--	Information yet to be received	Master trip relay	--	No	No	
4	400 KV ARAMBAG NEW RANCHI	12.01.17	14:40	12.01.17	15:49	SPURIOUS TRIPPING	--	Information yet to be received	Master trip relay	--	No	No	
5	400KV RANGPO-TEESTA-III	17.01.17	20:13	17.01.17	22:16	SPURIOUS TRIPPING	--	DT Received	Relay mal operation	--	No	No	
6	400 KV BARH - GORAKHPUR #I	19.01.17	15:10	19.01.17	19:17	DIFFERENTIAL PROTECTION OF L/R AT BARH	--	Information yet to be received	Information yet to be received	--	No	No	
7	400KV FARAKKA-KAHALGAON-III	21.01.17	10:22	21.01.17	10:42	DT RECEIVED AT KAHALGAON	--	Did not trip	DT Received	--	--	No	Main breaker was not in service during the incident
8	400KV TEESTA-III - RANGPO	25.01.17	01:15	25.01.17	01:25	DUE TO RELAY TESTING WORK AT TEESTA - III	--	Information yet to be received	Information yet to be received	--	No	No	
9	220KV BOKARO-B - RAMGARH -I	29.01.17	12:02	29.01.17	13:20	SPURIOUS TRIPPING	--	Information yet to be received	Information yet to be received	--	No	No	
10	400KV TEESTA-III - RANGPO	29.01.17	17:40	29.01.17	18:23	SPURIOUS TRIPPING	--	Information yet to be received	DT Received	--	No	No	
No autorecloser operation observed in PMU data													
1	400KV BANKA-BIHARSHARIFF-II	19.01.17	12:45	19.01.17	15:25	R-N FAULT	<100	Information yet to be received	Information yet to be received	No autoreclose operation observed in PMU data	No	No	
2	400KV BIHARSHARIFF -BANKA-II	29.01.17	14:21	29.01.17	16:27	R-N FAULT	<100	Information yet to be received	Information yet to be received	No autoreclose operation observed in PMU data	No	No	
3	400 KV BARH - PATNA - IV	30.01.17	06:20	30.01.17	06:29	B-N FAULT	<100	B-N, Z-II, 50.11 km, 7.16 kA at Barh	B-N, 33.3 km, 6.62 kA, A/R successful at Patna end	Successful at Patna end only	No	No	Line was successfully auto-reclosed at 05:54 hrs and 06:02 hrs from both end