



Minutes
of
104th PCC Meeting

Date: 30.07.2021
Eastern Regional Power Committee
14, Golf Club Road, Tollygunge
Kolkata: 700 033

EASTERN REGIONAL POWER COMMITTEE

MINUTES OF 104TH PROTECTION COORDINATION SUB-COMMITTEE MEETING HELD ON 13.07.2021 AT 10:30 HOURS

Member Secretary, ERPC chaired the meeting. The meeting was convened through Microsoft Teams online platform.

List of participants is enclosed at **Annexure A**.

PART – A

ITEM NO. A.1: Confirmation of minutes of 103rd Protection Coordination sub-Committee Meeting held on 17th June 2021 through MS Teams.

The minutes of 103rd Protection Coordination sub-Committee meeting held on 17.6.2021 circulated vide letter dated 02.07.2021.

Members may confirm.

Deliberation in the meeting

Members confirmed the minutes of 103rd PCC Meeting.

PART – B

ITEM NO. B.1: Repeated Tripping of 220 kV Chandauti-Sonenagar D/C line & Total Power failure at 220 kV Sonenagar (BSPTCL) S/s.

A. On 01.06.2021 at 11:56 Hrs

At 11:56 hrs, 220 kV Chandauti-Sonenagar D/C got tripped leading to total power failure at 220/132 kV Sonenagar (BSPTCL) and radially connected 132 kV substations.

Load Loss: 80 MW

Outage Duration: 00:41 Hrs

B. On 07.06.2021 at 13:15 Hrs

At 13:15 hrs, 220KV Chandauti –Sonenagar (BSPTCL) D/C got tripped on Y-B phase-to-phase fault leading to total power failure at 220/132/33 kV Sonenagar S/S.

Load Loss: 120 MW

Outage Duration: 00:37 Hrs

C. On 21.06.2021 at 11:15 Hrs

220KV Chandauti –Sonenagar (BSPTCL) D/C got tripped on Y phase to earth fault leading to total power failure at 220/132/33 kV Sonenagar in BSPTCL system.

Load Loss: 104 MW

Outage Duration: 00:25 Hrs

D. On 24.06.2021 at 13:42 Hrs

220 kV Chandauti - Sonenagar - 1 was under shutdown. At 13:42 hrs, 220 kV Chandauti-Sonenagar- 2 was tripped from Chandauti (PMTL) end resulting in total power failure at 220/132 KV Sonenagar end leading to load loss of 80 MW at S'Nagar& Aurangabad at Bihar system. Power supply to Japla was also interrupted as it was being fed from Sonenagar 132 kV side.

Load Loss: 80 MW

Outage Duration: 00:20Hrs

E. On 30.06.2021 at 19:13 Hrs

220 kV Chandauti - Sonenagar-2 was under shutdown. At 19:13 hrs, 220 kV Chandauti-Sonenagar-1 was tripped from Sonenagar end only due to back up protection operation. As a result total power failure occurred at Sonenagar, Aurangabad, Japla, Kudra and nearby area.

Load Loss: 203 MW

Outage Duration: 00:17 Hrs

BSPTCL & Powergrid may explain.

Deliberation in the meeting

For disturbance on 01/06/21, Powergrid informed that fault was in both the circuits of 220 kV Chandauti- Sonenagar line. For circuit-1, 3-phase tripping occurred and then autorecloser was successful. For circuit-2, the autorecloser was successful however the line tripped on fault in reclaim time.

Regarding 3-phase autorecloser operation, Powergrid informed that they have intimated the issue to OEM for analysis of the event.

For disturbance on 07/06/21, BSPTCL informed that there was Y-B phase to phase fault in both the circuits of 220 kV Chandauti- Sonenagar line. Chandauti end cleared the fault in zone-1 of distance protection and at Sonenagar end carrier was received from Powergrid end and the fault was cleared in zone 1.

ERLDC informed that based on DR analysis it was observed that most of the cases more than one phases were involved during the fault and fault distance is between 40-50 km from Chandauti end. They further added that during disturbance on 21/06/2021, current of other phases increased up to a significant value during autorecloser dead time and single phase fault got converted into phase to phase fault at the A/R instance which is indicating clearance issues between line phases or jumpers.

Regarding tripping on 26/06/2021 & 30/06/2021, it was informed that only one circuit of 220 kV Chandauti-Sonenagar was in operation during the events. ERLDC explained that when one of 220 kV Chandauti- Sonenagar is out and in the event of fault in the second circuit, relay at Sonenagar end may not be able to clear the fault due to weak in-feed at Sonenagar. This might led to non-operation of auto recloser as well as delayed tripping from Sonenagar end.

BSPTCL responded that they had carried out thorough patrolling of the line in last week of June'21 and damaged insulators were found in several locations at the locations between 20-25 km from Sonenagar end. The damaged insulators had been replaced with polymer type insulators.

They added that no further trippings has been observed in the line since the insulator replacement

work.

Regarding ambiguity in fault location, it was informed that impedance values of the relay at Chandauti end was found incorrect which resulted in relay overreach and hence showing inaccurate fault location. The settings have already been rectified.

PCC advised BSPTCL to implement week infeed/radial feeder protection at Sonenagar end for 220 kV Chandauti – Sonenagar lines and advised Powergrid to implement permissive overreach (POP) protection at Chandauti end for the above line.

ITEM NO. B.2: Disturbance at 220 kV Chandauti(PMTL) Substation on 25.06.2021 at 16:04 Hrs

On 25-06-2021, 220 kV Chandauti – Sonenagar – 1 was under shutdown for maintenance work. At 16:04 hrs, 220 kV Chandauti – Sonenagar-2 got tripped from Chandauti end due to R phase to earth fault at 43 km from Chandauti.

Due to non-operation of main breaker at Chandauti end, LBB protection operated for Chandauti 220 kV bus-2. As a result, 220 kV main bus 2 at Chandauti along with following elements got tripped.

- I. 400/220 kV 500 MVA ICT 3
- II. 220/132 kV 200 MVA ICT 1 & 2

Load Loss: 94 MW

Outage Duration: 01:37 Hrs

Powergrid & BSPTCL may explain.

Deliberation in the meeting

PMTL informed as follows:

- *On 25-06-2021, 220 kV Chandauti – Sonenagar – 1 was under shutdown for maintenance work. However, the bus side isolator was in closed condition during the above shutdown. The CT of this circuit is positioned towards line side isolator.*
- *At 16:04 hrs, 220 kV Chandauti – Sonenagar-2 got tripped from Chandauti end due to R phase to earth fault at 43 km from Chandauti end.*
- *The SOTF protection of Main-2 Relay of 220 kV Chandauti-Sonenagar-1 got operated because zero sequence current of the above fault also flown through the CT secondary of 220 kV Chandauti – Sonenagar – 1 due to mutual coupling effect. This in turn initiated the LBB protection and as the current was already more than the LBB pick up value the LBB operated after 200 msec.*

*The report submitted by Powergrid is enclosed at **Annexure B. 2.***

ERLDC informed that to avoid this type of unwanted tripping, local earthing on either side of CT is recommended during the shutdown of the lines which are having schemes with CT positioned towards line side isolators.

PCC recommended that for shutdown of one circuit of any D/C line which are emanating from substations having DMT/DM bus configuration with CT positioned towards line side isolators, the bus side isolator of the circuit may be opened before closing the line earth switch. In addition to this, local earthing of the CT may also be carried out as an additional precautionary measure to avoid any unwanted tripping in the substation during fault in the other healthy circuit as well as for safety measures.

Powergrid informed that they generally follow the above operating procedure in sites where DMT/DM bus scheme is available, however in the present case inadvertently the same was not followed as a whole and one isolator was in closed condition.

PCC took a serious note of the incident and advised PMTL to strictly follow the general operating procedure of Powergrid in all while taking shutdown of any element/equipment.

ITEM NO. B.3: Disturbance at 220 kV Biharsharif Substation on 01.06.2021 at 17:10 Hrs

On 01.06.2021 at 17:10 hrs, all 220 kV lines, emanating from 220 kV Biharshariff (BSPTCL) tripped. As per the information received, R phase CT at LV side of 400/220 kV ICT- 2 got busted resulting in tripping of all emanating lines. Total load loss was around 180 MW at Ekangasarai / Rajgir / Baripahari / Hatida / Harnaut / Barh / Nalanda in Bihar system.

The detailed report by ERLDC is attached at **Annexure B.3.1**.

Load Loss: 180 MW,
Outage Duration: 01:10 Hrs

BSPTCL & Powergrid may explain.

Deliberation in the meeting

BSPTCL informed that the disturbance occurred due to bursting of LV side CT of 400/220 kV ICT-2 at Biharshariff.

The following elements got tripped during the disturbance.

Name	End 1	End 2
400KV/220kV 315 MVA ICT 1	ICT tripped from LV side on Master trip relay.	NA
400KV/220kV 315 MVA ICT 2	Inter-trip from HV side	ICT tripped on differential protection from HV side.
400KV/220kV 315 MVA ICT 3	ICT tripped from LV side on Master trip relay.	NA
400KV/220kV 315 MVA ICT 4	ICT tripped from LV side on Master trip relay.	NA
220 kV Biharshariff-Fatua-1	DP relay Zone-4 picked up.	tripped in zone-2 from Fatua end.
220 kV Biharshariff-Fatua-2	Tripped on Non-directional high set o/c Protection. DP relay Zone-4 picked up.	No Tripping

220 kV Biharshariff-Khizisarai D/C	Both circuit got tripped on non-directional high set o/c Protection. DP relay Zone-4 picked up.	No Tripping
220 kV Biharshariff-Tenughat	DP relay Zone-4 picked up.	Tripped on Z-2, R phase FC-1.096kA FD-177.5 km

They further informed that the time delay for zone-4 of distance relay had been kept at 500 msec whereas for non-directional high set O/C protection, it was set at 400 msec. As a result, all the above lines got tripped either on high set protection at Biharshariff end or zone-2 protection from remote end.

PCC advised BSPTCL to implement reduced time setting of the zone-4 protection in distance relay to 250 msec until the busbar protection at 220 kV Biharsharif get implemented.

BSPTCL stated that they had taken up with their higher authority for early commissioning of the busbar protection at Biharshariff.

Regarding simultaneous tripping of parallel ICTs at Biharshariff, they informed that necessary checking and tests had been carried out for all CTs on LV side of the ICTs. Further, shutdown of the ICT has been planned to carry out detail checking of the cable/wiring between HV & LV side of the ICTs. The report submitted by BSPTCL is enclosed at **Annexure B.3.2**.

They proposed for disabling the feature of extending inter-trip command from LV side to HV side of the ICT to avoid unwanted tripping of the parallel ICTs during any nearby fault. PCC advised BSPTCL to discuss the issue with Powergrid and if required, the same may be implemented in consultation with Powergrid.

Regarding CT failure, they intimated that preliminary analysis was done however reason for the failure could not be ascertained.

ITEM NO. B.4: Total power failure at 220 kV BTPS(BSPTCL)S/s on 01.06.2021 at 17:03 Hrs

On 01.06.2021 at 17:12 hrs, the following elements got tripped resulting in total power failure at 220 kV BTPS.

- I. 220 kV Hazipur-BTPS circuit- 1
- II. 220 kV Mokama-BTPS-2
- III. 220 kV BTPS-Begusarai D/C
- IV. 220 kV Begusarai-Purnea(PG) circuit-I
- V. 220 kV Begusarai-Khagaria circuit-2
- VI. 220 kV Begusarai- New Samastipur (Ujiyarpur) D/C
- VII. 220 kV Mokama(BGCL)-Biharshariff D/C

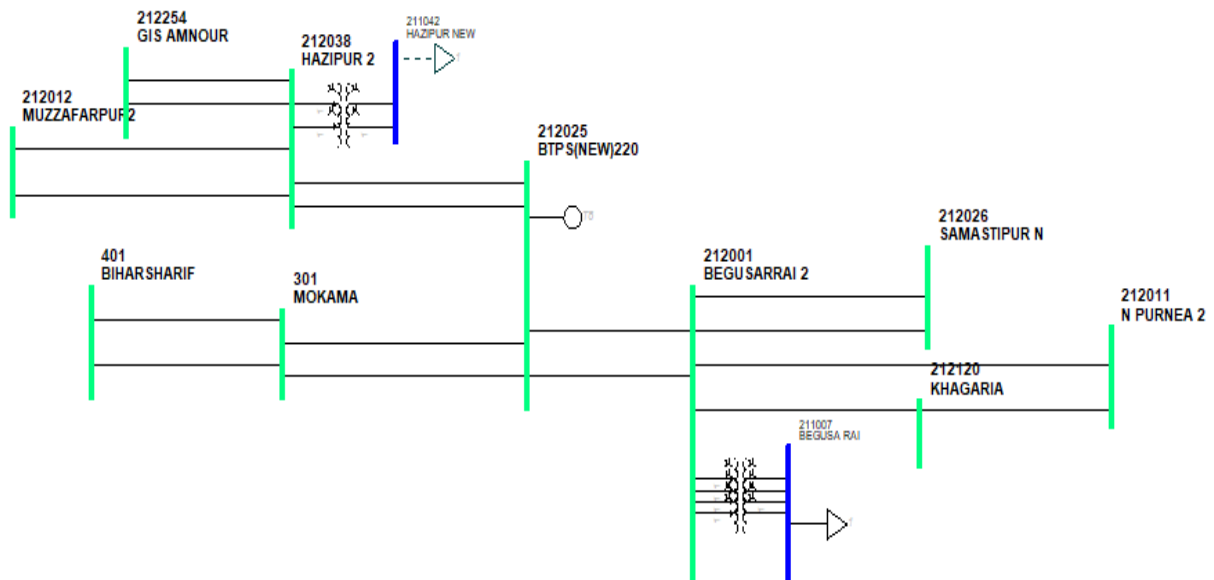

Load Loss :133 MW,
Gen. Loss:133 MW

Outage Duration: 00:52 Hrs

BSPTCL& BGCL may explain.

Deliberation in the meeting

It was informed that the weather was rainy with heavy thunderstorm & lightening during the disturbance.

BTPS representative informed that before the disturbance 220 kV Hazipur – BTPS circuit-2 and 220 kV BTPS – Mokama circuit-1 was not in service.

At 16:58 hr, 220 kV Hazipur – BTPS circuit-1 got tripped in overvoltage protection from 220 kV BTPS end. Subsequently at 17:03 hrs, 220 kV BTPS – Mokama circuit-2 and 220 kV BTPS – Begusarai circuit-2 also tripped in overvoltage protection from BTPS end.

BSPTCL representative informed that due to bad weather, multiple faults occurred in different lines. The 220 kV Begusarai – Samastipur D/C got tripped in zone-1 protection from both end and 220 kV Begusarai – Khagaria S/C tripped in zone 2 from Khagaria end. The fault location was near to Begusarai end. Regarding 220 kV Begusarai – Purnea circuit ,they informed that the line was under shutdown.

After tripping of the above circuits, BTPS was connected only to Begusarai S/s with remaining one circuit i.e. 220 k V BTPS – Begusarai circuit-1. Due to large load-generation mismatch, the BTPS units got tripped on over frequency and subsequently total power failure occurred in 220 kV BTPS S/s.

Regarding overvoltage setting at BTPS end, BTPS intimated that the setting was 110 % with time delay of 5 sec for all the 220 kV lines.

PCC observed that O/V settings of 110 % i.e. 242 kV is quite conservative keeping in view the fact that maximum permissible voltage limit as per CEA grid standard for 220 kV system is 245 kV. Also, it was observed that there was no voltage grading/time grading between the parallel lines emanating from BTPS end.

PCC opined that overvoltage settings, if kept in service, the tripping shall be set more than the permissible voltage limit. Also the settings need to be graded in terms of time/voltage for parallel lines connected to the same S/s. PCC advised BTPS to review their overvoltage protection settings in coordination with SLDC, Bihar in line with the above guidelines and the same may be submitted to ERLDC/ERPC as well.

BTPS further informed that high voltage is generally observed at BTPS end & the average voltage remain in the range of 230-235 kV.

PCC advised BTPS to share the voltage data along with the reactive power absorption data of their generating units to SLDC Bihar as well as to ERLDC for review.

ITEM NO. B.5: Disturbance at 220 kV Hazipur Substation on 09.06.2021 at 20:46 Hrs

As per information received, Y-phase bus coupler CT at 220kV Hazipur S/S got blasted leading to operation of bus-bar protection. Both buses became dead along with tripping of all outgoing lines emanating from Hazipur S/s. Total load loss reported was 300 MW at Hazipur and nearby areas.

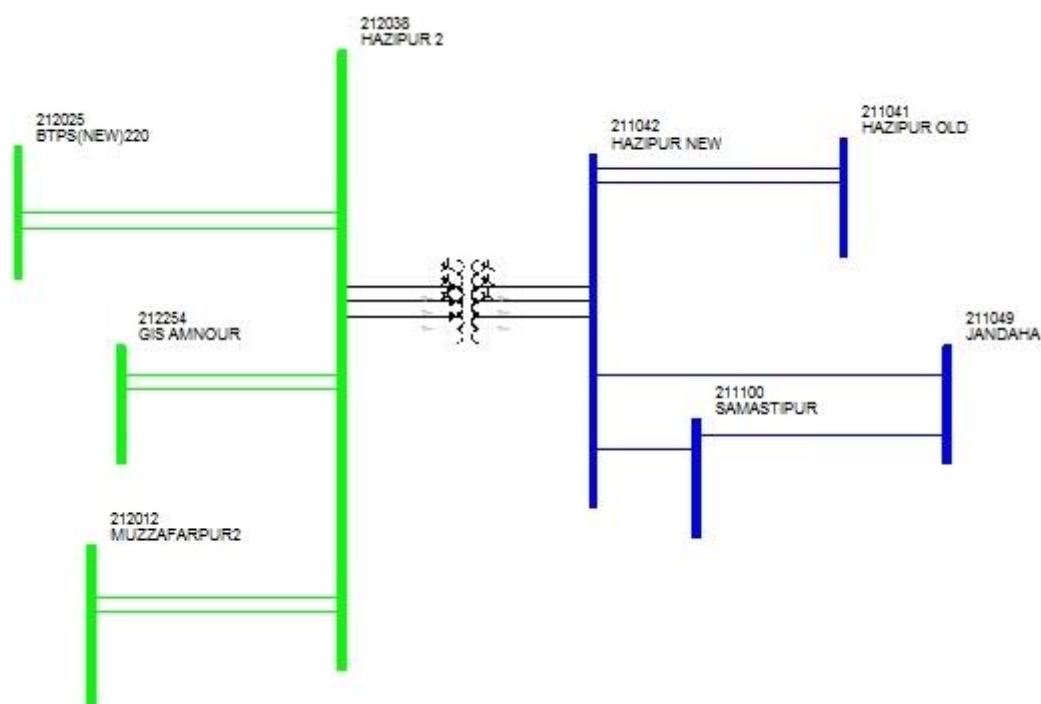

Load Loss : 300 MW
Outage Duration : 00:54 Hrs

BSPTCL may explain.

Deliberation in the meeting

BSPTCL informed that the disturbance occurred due to bursting of Y phase CT of bus coupler bay at Hazipur S/S. This led to operation of bus bar protection for both 220 kV bus-1 & bus-2 and tripped all the elements connected to these buses. As a result, total power failure occurred at 220 kV Hazipur S/s.

During discussion, it was informed by BSPTCL that CTs were present on both side of Circuit Breaker of Bus coupler bay. They clarified that as per the present busbar scheme, only one CT has been used for busbar protection instead of both the CTs.

PCC opined that the busbar scheme should be designed considering both the CTs of bus coupler bay so that the simultaneous tripping of both the buses could have been avoided during this disturbance.

PCC advised BSPTCL to explore the possibility of modifying the existing busbar scheme at 220 kV Hazipur S/s in order to have better security and reliability in operation of busbar protection during such type of disturbances.

ITEM NO. B.6: Grid Disturbance at Tashiding HEP on 25.06.2021 at 04:54 Hrs

On 01.06.2021 at 04:54 hrs, 220 kV Tashiding – Rangpo S/C and 220 kV Tashiding-New Melli S/C were tripped on Y-B fault. As a result, Both the running units of Tashiding HEP got tripped due to loss of evacuation path.

Gen. Loss : 90 MW

Outage Duration : 36:55 Hrs

Detailed report on this disturbance is attached at **Annexure B.6**.

Tashiding HEP & Powergrid may explain.

Deliberation in the meeting

Tashiding HEP explained as follows:

- *The fault occurred near LILO arrangement where Y-Phase conductor of both 220 kV Tashiding – Rangpo and 220 kV Tashiding-New Melli were detached from the tower and fell on the B phase of 220 kV Tashiding - Rangpo line creating Y-B phase to phase fault .*
- *As both the lines turned almost 90 degree at LiLO location, 220 kV Tashiding - Rangpo line crosses the 220 kV Tashiding-New Melli line. The same may be seen in the picture given below:*



- Moreover ,220 kV Tashiding - Rangpo line phases were supported with the help of composite insulators from the respective phases of 220 kV Tashiding - New Melli line to maintain the safe clearances.
- The Y-Ph composite insulator string of Tashiding-New Melli line was broken into two parts from near to lower end of the string.
- While detaching of the Y-Ph of Tashiding - New Melli line from the tower arm, it also pulled the Y-Ph of Tashiding -Rangpo line and consequent to this Y-Ph conductors of both lines detached from the Tashiding tower arm and fell over the B-Ph of Tashiding -Rangpo line resulting into Y-B phase fault.

Regarding restoration of the lines, they informed that at present lines were restored with temporary arrangement. The permanent restoration of the lines would be done within a week.

ERLDC informed that trippings had been observed in both of these lines due to the fault in the similar location. They apprehended that there might be clearance issues at that location which needs to be looked into.

Tashiding HEP responded that the previous trippings were due to wrong settings in the relay at their end & the after rectification in the relay settings the trippings were not being observed.

However they agreed to look into any clearance related issues at that location and stated that the same would be checked during permanent arrangement of the circuits at the tower location & findings would be submitted to ERLDC/ERPC.

ITEM NO. B.7: Bus-bar tripping occurred in Eastern Region during June 2021

During June 2021, following incident of bus bar tripping have been observed in Eastern Region. Concerned utilities are requested to explain.

Element Name	Tripping Date	Reason	Utility
400 kV Main bus - 1 at Motihari	02-06-2021 at 21:17 Hrs.	LBB operated while making charging attempt for 400 KV Barh-Motihari-1 line	DMTCL

DMTCL may explain.

Deliberation in the meeting

DMTCL informed that 400 kV Barh-Motihari-1 line got tripped due to conductor snapping in the line. During charging attempt of the line, LBB operated and tripped the 400 kV Bus-1 at Motihari S/s.

They informed that the data related to this tripping could not be extracted from the relays due to issue in software version of the relay. The same would be resolved within a day.

PCC advised DMTCL to analyze the tripping after extracting the DR information from the relays and submit a report to ERPC/ERLDC regarding the above tripping.

ITEM NO. B.8: Repeated tripping of Transmission lines due to the same nature of fault.**A. 400 kV Bokaro-Koderma D/C**

- 400 kV Bokaro - Koderma line tripped 5 times in the month of June'21. The details of the tripping is provided below along with remarks based on analysis of DR/EL.
- The frequent tripping of transmission lines increases the possibility of power interruption and also endangering the healthiness of connected generating plants i.e. Bokaro&Koderma TPS.
- As per the DR signature analysis, it was observed that most of the faults are due to lightning, and location also found same in 3 events hence Tower footing resistance, Shielding/ground wire near the location may be checked to ensure. Details are attached in the **Annexure B8.1.**

Element Name	Tripping Date	Tripping Time	Reason	Remarks
400KV-KODERMA-BOKARO-1	21-06-2021	17:20	Koderma -Earth Fault,Y-ph,FD-100km, FC-3.08 kA	Fault location same as of 13/06.
400KV-KODERMA-BOKARO-2	13-06-2021	15:37	KODERMA: Y-B-N, Fd= 71.2 kA, Iy= 5.57 kA, Ib= 4.5 kA	DR signatures show a lightning fault first to Y-phase and then B-phase indicating back flashover.
400KV-KODERMA-BOKARO-1	13-06-2021	15:37	Koderma: Y-B-N, Fd= 101.9 km, Ib= 4.29 kA, Iy= 3.28 kA	
400KV-KODERMA-BOKARO-1	04-06-2021	13:56	KODERMA- Y-N fault, Zone 1, FD -50.5 km, FC -5.5 kA. BOKARO - A/R SUCCESSFUL.	DR signatures show a lightning nature of fault.
400KV-KODERMA-BOKARO-2	01-06-2021	14:07	Koderma :B-phase ,E/F (Ic =1.35 kA)	DR not received.

Powergrid& DVC may explain.

Deliberation in the meeting

ERLDC informed that 400 kV Bokaro – Koderma had tripped several times in month of June 2021 and most of the time fault is similar in nature with same location .

DVC informed that in most of the cases the fault signature indicates the reason of the fault as lightning.

Regarding incident on 01/06/21 & 04/06/21, Powergrid informed that tower footing resistance had been measured for locations upto 50 km from Koderma end however, no abnormality was observed.

For the disturbance on 13/06/21 & 21/06/21, they informed that the fault location could not be confirmed due to non-availability of DR from BTPS end.

DVC informed that the fault location for the above incidents was 4-5 km from BTPS end however they would submit the relevant DR to Powergrid within a day.

PCC advised Powergrid to check tower footing resistance in the concerned section of the line and submit the findings to ERPC/ERLDC.

B. Tripping of 400 kV Binaguri-Alipuduar- 1 on O/V Stage-I

It has been observed that 400 kV Binaguri-Alipurduar-I is tripping on O/V STG-1 while there is no such actual overvoltage issue existing in the line. Details of tripping are mentioned below.

Sr. No	Element Name	Tripping Date	Tripping Time	Reason
1	400 kV Alipurduar-Binaguri -I	29-06-2021	05:04	O/V Stage-I operated at Alipurduar end.
2	400 kV Alipurduar-Binaguri -I	01-06-2021	01:05	O/V Stage-I operated at Alipurduar end.
3	400 kV Alipurduar-Binaguri -I	22-04-2021	01:18	O/V Stage-I operated at Alipurduar end.
4	400 kV Alipurduar-Binaguri -I	30-03-2021	03:41	O/V Stage-I operated at Alipurduar end.

For each tripping, it is observed that the Alipurduar end Y phase voltage is 17 kV higher than the rest two phases, while at the Binaguri end no such thing observed. This indicates that there is no such actual voltage rise existing in line due to mutual induction or transposition.

DR Comparison has been shown in the attached **Annexure B8.2**.

Powergrid may explain.

Deliberation in the meeting

Powergrid informed that the overvoltage issue was due to damage in the CRP cable in switchyard. The cable has been changed and presently there is no overvoltage issue at Alipurduar end.

C. Multiple tripping of 132 kV Sultanganj-Deoghar-S/C.

It has been observed that in recent times 132 Sultanganj-Deoghar S/C has been tripped multiple times. In the month of June'21, the line had tripped 5 times with Y phase to earth fault on each occasion.

A list of tripping of the past six months is shown below where almost at all instances the said line tripped due to Y-earth fault. Forced outage on account of tripping of this circuit reduces the reliability of both the JUSNL and BSPTCL system (Chitra, Deoghar Railway).

Sr.No	Element Name	Tripping Date	Tripping Time	Reason	Revival Date	Revival Time
1	132 kV-Sultanganj-Deoghar-1	28/06/2021	9:55	O/C E/F	28/06/2021	10:05
2	132 kV-Sultanganj-Deoghar-1	27/06/2021	6:10	Sultanganj-Z1 R-N FC-R-3.109KA FD-- 9.145km	27/06/2021	6:35
3	132 kV-Sultanganj-Deoghar-1	26/06/2021	9:02	Sultanganj: Z-2, fault distance - 115.7km, Fault current: Y- 787.3A	26/06/2021	10:02

4	132 kV-Sultangunj-Deoghar-1	11/6/2021	21:20	O/C E/F, Fault distance 121.5km, Fault current R-759.7A, Y-100A, B-272.9A, Zone- 02	11/6/2021	21:54
5	132 kV-Sultangunj-Deoghar-1	2/6/2021	23:08	Master Trip Load loss: 20 MW at 132 KV Chitra and 5 MW at Deoghar.	2/6/2021	23:17
6	132 kV-Sultangunj-Deoghar-1	2/6/2021	3:35	Sultan: DP, Y-n, z1, 55.48 km, 1.3 kA	2/6/2021	3:51
7	132 kV-Sultangunj-Deoghar-1	1/6/2021	17:55	SULTANGANJ:- Relay-O/C E/F distance prot.optd .Fault distance-21.69km, Fault current-2.175kA in Y phase	1/6/2021	18:40
8	132 kV-Sultangunj-Deoghar-1	25/05/2021	6:25	Sultanganj: O/C, E/F master trip distance prot.Optd; Fault distance-13.23km; Fault current- 2.550kA in Yphase ; Zone-01	25/05/2021	7:10
9	132 kV-Sultangunj-Deoghar-1	3/4/2021	11:45	O/C, E/F, distance prot operated.	3/4/2021	12:16
10	132 kV-Sultangunj-Deoghar-1	26/03/2021	7:25	Sultanganj-Z-1, 23.97kM, Y-ph, lf=1.97kM	26/03/2021	7:43
11	132 kV-Sultangunj-Deoghar-1	22/03/2021	11:25	sultangunj:Z1, Y-B ; 70.44km; lY-1.556kA, B-1.445kA	22/03/2021	12:00
12	132 kV-Sultangunj-Deoghar-1	23/01/2021	8:11	Y_N fault, 88 KM	23/01/2021	13:32
13	132 kV-Sultangunj-Deoghar-1	23/01/2021	7:38	Y_N, 0.9 kA, 92 KM (Sultanganj)	23/01/2021	8:05

BSPTCL & JUSNL may explain.

Deliberation in the meeting

BSPTCL informed that the line length is around 90 km out of which approx. 60 km falls under Bihar jurisdiction. JUSNL responded that only 8 km of 132 kV Sultanganj-Deoghar line from Deoghar end is under JUSNL jurisdiction.

PCC advised BSPTCL & JUSNL to reconfirm their jurisdiction in 132 kV Sultanganj-Deoghar line and to coordinate with each other in resolving the ambiguity related to the jurisdiction issue.

BSPTCL stated that regular patrolling was carried out for their section of the line and clearance issues had been found in certain locations. They added that they are facing difficulties in clearing the vegetation in some of the locations due to local issue.

PCC advised BSPTCL & JUSNL to resolve all pending clearance issues in their respective sections at the earliest.

They further apprehended that in some of the trippings, the fault location is more than 100 km

which indicates that fault was in some other line from Deoghar end. As the faults did not get cleared from Deoghar end, it resulted in tripping of the 132 kV Sultanganj-Deoghar line from Sultanganj end. PCC advised JUSNL to review the protection settings of the relays at Deoghar end for all the other lines.

ITEM NO. B.9: Status of Islanding Schemes in Eastern Region

1. KBUNL Islanding Scheme

In special meeting held on 08.06.2021, following deliberations were made –

1. KBUNL Islanding scheme would be designed considering both units of KBUNL stage-II (2x195 MW) as participating generator and connected radial loads at Gopalganj along with in-house load of KBUNL.
2. The islanding frequency will be at 48.6 Hz and this is subject to revision based on the suggestion received from KBUNL/OEM on underfrequency settings of the generator units.
3. Based on the revised simulation study result, ERLDC would communicate the desired frequency band to KBUNL for their units for stable operation of the islanding scheme. KBUNL would review the proposed range for frequency settings in consultation with their engineering wing & OEM and communicate their observation to ERLDC in this regard. They would also take up for dynamic simulation study with regard to islanding mode of operation of the units.
4. KBUNL would confirm the provision of Islanding mode of operation in the governors of their Stage-II units.
5. Based on the response received from KBUNL to the above queries, a separate meeting would be convened to discuss further course of action.
6. KBUNL would expedite the construction work related to implementation of Islanding scheme in switchyard. They would also take up with concerned OEM for testing and commissioning of islanding relay panel at their end.
7. BSPTCL to submit the present status of the availability of communication channels (i.e. availability and status of OPGW, PLCC, DTPC coupler) in the transmission lines/substations considered under KBUNL islanding scheme.

KBUNL& BSPTCL may update.

Deliberation in the meeting

NTPC informed that they had approached OEM for getting their views/observations with regard to Islanding mode of operation in KBUNL units. However, no response have been received from them till date.

Regarding proposed range in frequency settings, they mentioned that the settings have been forwarded to their engineering wing for review.

MS, ERPC stressed that the islanding scheme is being monitored in highest level of Govt of India & advised all concerned utilities to take the matter on priority & expedite the work related to implementation of islanding schemes.

NTPC replied that they would furnish the latest updates within a week.

Regarding bay construction work at KBUNL switchyard, they updated that it would be completed

within the target date i.e. Sep'21.

BSPTCL submitted the present status of the communication channels in the transmission lines under KBUNL scheme. The report is enclosed at **Annexure B.9.1**. They submitted that all pending work would be completed within a month.

2. CTPS Islanding Scheme

In special meeting held on 08.06.2021, following deliberations were made –

1. ERLDC would share the simulation study report with all concerned in DVC i.e. SLDC DVC, SPE wing of DVC & CTPS-B.
2. The CTPS-B islanding scheme is to be designed with two units of CTPS-B (2x250 MW) generating station as participating generator and connected loads at CTPS, Putki, Biada, Nimiaghata&Patherdih.
3. The islanding frequency for CTPS-B islanding system was decided as 48.4 Hz.
4. CTPS-B would take up with their OEM for confirmation of the following
 - Provision of Islanded mode of operation in the governor of CTPS-B units.
 - Provision for increasing the turbine over frequency settings to a higher value or enhancement of the time delay in existing settings.
 - Detail study of islanding response of CTPS units based on the necessary simulation at islanding frequency of 48.4 Hz.
 - Detailed study on dynamics of governor and turbine during formation of island at islanding frequency of 48.4 Hz.
5. DVC would take up with concerned OEM for necessary installation & testing of islanding panel at CTPS-B end.

DVC may update.

Deliberation in the meeting

ERLDC informed that the simulation study report had already been shared with DVC.

The status of the islanding scheme could not be updated as no representative of CTPS as well as SLDC, DVC was available in the meeting.

3. IB-TPS Islanding Scheme

In special meeting held on 09.04.2021, OPGC representative informed the followings:

- a) PLCC work has already been completed and the signal is available at their end.
- b) The annual overhauling of IBTPS is scheduled on 17th April 2021 for 25 days.
- c) OEM (BHEL) is developing a new scheme and the same would be implemented during the overhauling period after getting confirmation from OEM.

OPGC was advised to share the requisite details to ERPC secretariat at the earliest.

OPGC may update.

Deliberation in the meeting

OPGC informed that as per the recommendation of their OEM(M/s BHEL), since governor of the 1b TPS units are quite old, the units can be run in islanded mode of operation only if the load variation lies within 5 %.

PCC opined that the load variation is inherent in any of the islanding system. However, the islanding study is always carried out considering 5 % droop of the unit & keeping other constraints of the units into consideration. In case of any technical constraints, UFR based load shedding within island or any other SPS mechanism can be implemented.

PCC advised OPGC to consult their OEM & submit the OEM recommendation/observation regarding all the constraints in the generating units with respect to islanding mode of operation to ERLDC by July'21.

4. Patna Islanding Scheme

In special meeting held on 29.06.2021, BSPTCL was advised to submit the followings:

- Revised load details of Patna city (excluding the traction load & loads covered under AUFLS) considering maximum load that can be accommodated under islanding scheme as 550 MW. Also, the above load figures may be calculated based on the actual load pattern for last 1-2 years period.
- Network map indicating all 220 kV & 132 kV substation details which are to be included in the islanding scheme along with the disconnection points. The network map has to be prepared taking into consideration the substations/lines to be commissioned in near future. The timeline of the upcoming substation/lines has also to be submitted.
- To submit availability as well as type of communication systems present in lines/substations inside the island network.
- Further the proposed load & network connections for Islanding scheme need to be modelled and submitted as PSSE base case.

NTPC was also advised to submit requisite details within a week for carrying out islanding simulation study.

SLDC Bihar & NTPC may update.

Deliberation in the meeting

SLDC, Bihar updated that revised load details along with network map & details of upcoming nearby substations had been submitted to ERLDC. The PSSE base case would be shared within a week.

ERPC informed that from the network map of the proposed Patna islanding Scheme with the new upcoming 400 kV sub-stations, it is observed that number of switching of 400 kV lines would be reduced if the Nabinagar units of NPGC is considered as participating generator. It was suggested to relook into the designing of the islanding scheme with NPGC units.

PCC advised ERLDC to carry out the simulation study for Patna islanding scheme by considering different cases with Barh and NPGC units separately.

PCC advised NTPC to submit requisite generator details of Barh as well as NPGC to ERLDC.

5. Ranchi Islanding Scheme

In special meeting held on 29.06.2021, JUSNL was advised to submit the followings:

- Category wise bifurcation of the load (essential, critical etc.)
- Details of new substation/lines to be commissioned in near future with timeline and their connectivity and load details.
- Network map indicating all 220 kV & 132 kV substation details which are to be included in the islanding scheme along with the disconnection points. The network map has to be prepared taking into consideration the substations/lines to be commissioned in near future. The timeline of the upcoming substation/lines has also to be submitted.
- The proposed load & network connections for Islanding scheme need to be modelled and submitted as PSSE base case.
- Availability as well as type of communication systems present in lines/substations inside the island network.

SLDC Jharkhand may update.

Deliberation in the meeting

It was informed that all the necessary detail had been received from SLDC, Jharkhand except PSSE base case and network model.

SLDC Jharkhand submitted that PSSE base case and network model would be shared within a week.

ITEM NO. B.10: Tripping Incidence in month of June 2021

Tripping incidents in the month of June 2021 which needs explanation from constituents of either of the end is enclosed.

Concerned utilities may explain.

Deliberation in the meeting

*Members explained the tripping incidences. Updated status is enclosed at **Annexure B.10**.*

PCC advised all the concern constituents to take necessary corrective actions to resolve the issues.

PART- C:: OTHER ITEMS

ITEM NO. C.1: Submission of protection settings in PDMS

Relay settings of many transmission elements are not available in the protection database. The list has been prepared and forwarded to all the concerned utilities.

Relay settings had been received from CESC, Haldia Energy Limited and for few Substations from Powergrid ER-1. OPTCL, WBSETCL, JUSNL, BSPTCL, WBPDC, Powergrid ER-II, NTPC and other constituents are required to submit relay settings at earliest.

In 100th PCC Meeting, it was informed by ERPC secretariat that an audit by PSDF audit team was carried out for protection Database project on 19.02.2021 and it was noted that around 7 percent of protection settings was not available in PDMS.

PCC advised all concerned utilities to upload the pending relay settings in PDMS or send the relay settings to erpcprotection@gmail.com.

In 103rd PCC, PCC advised all concerned utilities to upload the pending relay settings in PDMS or send the relay settings to erpcprotection@gmail.com.

Members may update.

Deliberation in the meeting

PCC advised all concerned utilities to upload the pending relay settings in PDMS or send the relay settings to erpcprotection@gmail.com.

ITEM NO. C.2: Backup Overcurrent Relay coordination for Sikkim Complex.

In 97th PCC following deliberations were made,

It was informed that IDMT characteristics were implemented at Jorethang and Tashiding.

In 103rd PCC following deliberations took place –

Powergrid informed that the protection philosophy for backup protection of lines & ICTs being followed by them in Sikkim Complex is as follows:

- *Philosophy of T-op for Lines = (Z3 + 0.1) Sec,*
- *Philosophy of T-op for Transformer = (Z3+0.1) for O/C & (Z3+0.2) for E/F*

However, the proposed settings for ICTs based on PRDC study is:

- *T-op for HV & LV side=0.8 Sec for O/C and T-op for HV & LV= 1.4 sec for E/F*

They suggested to review the proposed settings in line with their existing settings for lines & ICTs in Sikkim Complex.

They further informed that zone 3 settings of 400 kV Kishangunj-Rangpo line is 1.5 second whereas proposed settings for backup overcurrent relay of line is 1.2 second which would result in tripping of DEF before zone 3 of distance protection.

PCC advised PRDC to carry out revised study considering the existing zone-3 settings by Powergrid and share report among concerned utilities for implementation of revised settings at their end.

Concerned utilities may update.

Deliberation in the meeting

PRDC informed that the revised study considering the zone-3 settings of the transmission lines in Sikkim Complex would be completed within a week.

PCC advised PRDC to share the report among concerned utilities for implementation of revised settings at their end.

ITEM NO. C.3: Transformer overcurrent earthfault Setting Guidelines-ERLDC

In the recent past few uncoordinated tripping of Transformers have been observed where conservative earth fault overcurrent setting is found to be the main reason.

As presently there are no setting guidelines in the protection philosophy of ERPC on this aspect, there is a need for introducing a general guideline to help utilities avoiding any conservative setting and uncoordinated tripping. One such general guideline for the earth fault overcurrent setting is provided below for discussion.

- A. The primary requirement for the stage 1 setting should be to detect earth faults at the local bus bar, where the transformer winding is connected. Therefore, a fault calculation should be made as per figure 1. This calculation provides the current fed to the protection i.e. $3I_{ofault1}$. To assure that step 1 calculation to have selectivity for other earth-fault protection in the network, a short delay may be selected. Normally, a delay in the range of 0.3 – 0.4 s is appropriate under such conditions.

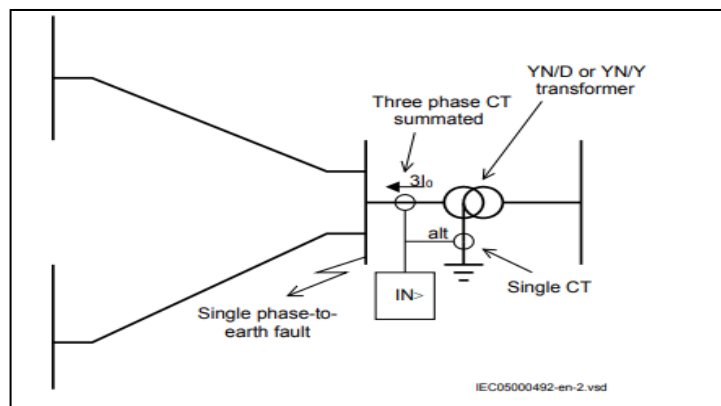

Figure 1: Step 1 fault calculation 1

Further to ensure selectivity to delayed line faults clearance at the local bus (typically distance protection operation in zone 2 in 0.5 sec), the current setting must be set high enough so that these faults do not result in unwanted step 1 trip of transformer on earth fault stage 1 setting.

Therefore, a fault calculation as shown in figure 2 is also required to be done. If the fault is located at the borderline between the instantaneous and delayed operation of the line protection (such as Distance protection or line residual overcurrent protection), the above calculation gives the current fed to the protection i.e. $3I_{ofault2}$ the setting of step 1 can be chosen within the interval shown relation given below for the above calculations.

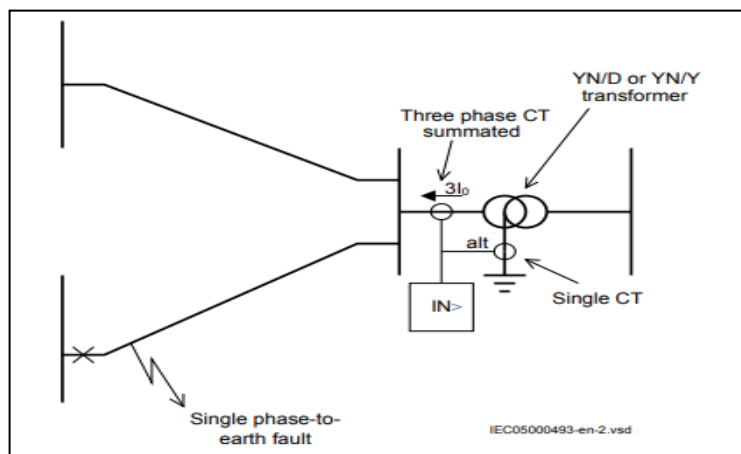

Figure 2: Step 1 fault calculation 1

$$3I_{0\text{fault}2} \cdot \text{lowmar} < I_{\text{step}1} < 3I_{0\text{fault}1} \cdot \text{highmar}$$

Where **lowmar** is a margin to assure selectivity (typical 1.2) and **highmar** is a margin to assure fast fault clearance of busbar fault (typical 1.2)

Earth fault overcurrent Stage 2 setting:

The setting of the sensitive step-2 is dependent on the chosen time delay therefore often a relatively long definite time delay or inverse time delay is selected. For this, a very low current setting (Minimum setting possible) can be selected as it is required to detect earth faults in the transformer winding, close to the neutral point. However, zero-sequence currents that can occur during normal operation of the power system are also required to be considered while selecting this current value for pickup.

In 103rd PCC , It was informed that Powergrid had submitted their protection philosophy for earth fault relay in transformers. CESC had shared the backup protection setting details of their transformers

DVC informed that they would share their philosophy within a week.

PCC advised all other utilities to share their practice used for defining E/F overcurrent settings in transformer to ERPC and ERLDC.

Further PCC advised ERLDC to prepare a draft report/recommendation for backup E/F overcurrent relay settings in transformer based on the philosophies received from utilities and share the same to all utilities so that the recommendations can be finalized in next PCC Meeting.

*ERLDC vide e-mail dated 02/07/2021 circulated the recommendation for backup O/C & E/F settings for Transformers among all the utilities. The report is also enclosed at **Annexure C.3**.*

Members may discuss.

Deliberation in the meeting

ERLDC told that they need to do some modifications in their report.

DVC told that it would be better to set definite time 100 ms as time settings for hv / lv overcurrent E/F instead of 30 -50 ms as suggested by ERLDC. It further told that for adjusting P.S . , factor of 130 % may be considered instead of 110 % as suggested by ERLDC.

Powergrid told that it would be better to set definite time 50 -100 ms as time settings for hv / lv overcurrent E/F. It further told that for adjusting P.S . , factor of 110 -120 % may be considered instead of 110 % as suggested by ERLDC.

PCC advised other utilities that had not submitted their practice till date to share their practice used for defining E/F overcurrent settings in transformer to ERPC and ERLDC.

PCC also informed that these are general recommendations and these guideline may be fine-tuned by the utilities as per their existing practices.

PCC advised ERLDC to do modifications in their report according to suggestions received from other utilities and share with all the utilities.

ITEM NO. C.4: Protection coordination of the New Transmission elements to be charged in Eastern Region

1. LILO of 400 kV Sagrdighi -Subhasgramat 400 kV Jeerat S/s

As per information received at ERLDC, 400 kV Sagrdighi -Subhasgram will be liloed at 400 kV Jeerat. Details of the line (as received at ERLDC)

Name	Conductor type	Length
400 kV Sagrdighi -Jeerat	ACSR Twin Moose	199.76 km
400 kV Jeerat -Subhasgram	ACSR Twin Moose	64.06 km

As per information available at ERLDC, protection coordination may be required as per the following table.

Reason	S/S may be affected	Remarks	Utility to respond	Response received
Lilo of 400 Kv Sagrdighi -Subhasgram at Jeerat	Sagardighi	Protection coordination to be done for all newly connected elements as per ERPC's guidelines. The longest line will change from Sagardighi - Subhasgram to Sagardighi - Jeerat.	WBPDCL	Protection coordination has been done as per ERPC's guidelines. Relay settings yet to be received.
	Subhasgram	Protection coordination to be done for all newly connected elements as per ERPC's guidelines. Longest line will change from Sagardighi - Subhasgram to Subhasgram - Jeerat. Kindly check and confirm any setting revision.	POWERGRID ER-2	Protection coordination has been done as per ERPC's guidelines. Relay settings yet to be received.
	Jeerat	Protection coordination to be done for all newly connected elements as per ERPC's guidelines. Longest line will change from Sagardighi -Jeerat to Sagardighi -Jeerat(Lilo) but that will only cause difference in 1.7km in line length. Kindly check and confirm if any setting revision required.	WBSETCL	Protection coordination has been done as per ERPC's guidelines. Relay settings yet to be received.
	S/S connected to Sagardighi, Jeerat and Subhasgram: Haldia ,Rajarhat, Farakka , Durgapur ,BehrampurB akreswar, Chanditala	For Haldia and Rajarhat adjacent longest line will change and it will reduce significantly, so Zone-3 settings will be affected. Also for Farakka, Durgapur, Behrampur adjacent longest line will reduce. Kindly check and confirm any setting revision for change in the adjacent short line.	POWERGRID ER-2/WBSETCL/ WBPDCL	Protection coordination has been done as per ERPC's guidelines. Relay settings yet to be received.

Powergrid, WBSETCL & WBPDCCL may update.

Deliberation in the meeting

PCC advised Powergrid, WBSETCL and WBPDCCL to share revised relay settings at their respective ends to ERPC/ERLDC.

2. 220 kV Jeypore(PG)-Jayanagar(Odisha) III & IV :

Protection coordination has been done as per ERPC’s guidelines. Relay settings are yet to be received.

Powergrid & OPTCL may update.

Deliberation in the meeting

PCC advised Powergrid and OPTCL to submit relay settings at their respective end for 220 kV Jeypore(PG)-Jayanagar III & IV line to ERPC/ERLDC.

3. LILO of 400 kV Patna –Kishanganj at Saharsa

As per information received at ERLDC, 400 kV Patna -Kishanganj will be looped in loop out at Saharsa.

Name	Conductor type	Length
400 kV Patna -Kishanganj-I	ACSR Quad Moose	410 km
400 kV Patna -Kishanganj-II	ACSR Quad Moose	420 km

Protection coordination may be required as per the following table.

Reason	S/S may be affected	Remarks	Utility to respond	Response received
400 kV Patna - Kishanganj looped in loop out at Saharsa	Patna	Protection coordination to be done for all newly connected elements as per ERPC’s guidelines. Line Length will increase from 350 to 410/420 Km.	POWERGRID ER-1	Yet to be received
	Kishanganj	Protection coordination to be done for all newly connected elements as per ERPC’s guidelines. Line Length will increase from 350 to 410/420 Km.	POWERGRID ER-1	Yet to be received
	S/S connected to Patna & Kishanganj: Barh , Balia , Npgc , Binaguri , New Purnea , Rangpo , Teesta-	For all adjacent substations connected to Patna & Kishanganj, adjacent longest line length will increase significantly, so Zone-3 settings will be affected. In the case of Zone 2 & Zone 3 overlap of adjacent sections Time grading to be ensured. Kindly check and confirm any setting revision if required.	POWERGRID ER-1&2, NPGC/NTPC BARH/DMTCL/TVPTL	Yet to be received

Following Details to be shared:

- POWERGRID ER-1, ER-2, NPGC, NTPC BARH, ATL (Darbhanga), TVPTL may share whether revision of any existing protection setting at above mentioned S/S is required or not. In case of any revision, the revised setting may be shared with ERPC and ERLDC.
- The protection setting at Patna & Kishanganj may be shared with ERPC and ERLDC.
- Status of carrier protection and PLCC channel in the all above-mentioned section may be shared.

Concerned utilities may update.

Deliberation in the meeting

PCC advised Powergrid to submit revised protection settings at Patna & Kishanganj end for necessary update of the same in protection database.

PCC also advised concerned utilities to review the protection settings at their substations for the lines connected to Patna & Kishanganj S/s. In case of any revision, the revised setting may be shared with ERPC secretariat and ERLDC.

ITEM NO. C.5: Upcoming new elements for which Protection coordination confirmation will be required from Utilities

A. 400 MPL-Ranchi LILO at 400/220 kV Dhanbad substation

Information has been received that 400/220 kV Dhanbad NKTL substation will be charged shortly. 400 kV Dhanbad S/S is owned by North Karanpura Transco Limited (a SPV of Adani Transmission). The following list of elements will be first time charged in near future.

a.

Name	Conductor type	Length
400 kV MPL-Dhanbad D/C	ACSR Twin Moose	24.7 km
400 kV Ranchi-Dhanbad D/C	ACSR Twin Moose	165 km

b. 500 MVA 400/220 kV ICT-I & II along with associated bays at Dhanbad S/s.

MPL , Powergrid Ranchi as well as connected remote ends substation from 400 kV MPL & Ranchi S/s may kindly check if there is any requirement to change their protection setting.

Concerned utilities may update.

Deliberation in the meeting

Concerned utilities were advised to review their protection settings in view of the LILO of 400 kV MPL-Ranchi D/C line at Dhanbad and in case of any revision, the revised setting may be shared with ERPC secretariat and ERLDC.

PART- D:: FOLLOW-UP OF PREVIOUS PCCM

ITEM NO. D.1: Disturbance at Bodhgaya S/S on 17/05/2021 at 23:06 Hrs

At 23:06 hrs, 220 kV Gaya-Bodhgaya-1 & 2 tripped from Gaya end only. At the same instance, all 220/132 KV ICTs at Bodhgaya also tripped causing load loss of 150 MW at Chandauti, Sherghati, Imamganj, Bodhgaya&Rafiganj Traction. 220 KV Bodhgaya-Khijasarai D/C was hand-tripped from Bodhgaya end.

In 103rd PCC,after detailed deliberation PCC advised followings to BSPTCL:

- To check reason for non-operation of zone-4(reverse zone) in distance relay for 132 kV Bodhgaya-Paharpur-1 circuit.
- To check whether all five ICTs were tripped at the same time during disturbance. In case of difference in tripping time, review of the backup overcurrent &earthfault protection of ICTs is required taking into consideration of the fact that capacity of ICT-5 is 160 MVA and capacity of all other ICTs are 150 MVA.
- The reviewed backup protection settings of ICTs need to be communicated to Gaya end of Powergrid so that zone-3 timing for 220 kV Gaya-Bodhgaya D/C lines can be coordinated accordingly.
- To configure the disturbance recorders at Bodhgaya end as per the PCC guidelines finalized in 79th PCC meeting and also to time synchronize all the relays at Bodhgaya end.
- To upgrade relay of ICTs at Bodhgaya end so that DR can be extracted for disturbance analysis.

PCC also advised BSPTCL to explore for implementation of double main transfer bus (DMT) or Double bus switching scheme for 220 kV Bodhgaya S/s and also to implement busbar protection at 220 kV level as per the CEA guidelines.

BSPTCL may update.

Deliberation in the meeting

Regarding implementation of bus bar protection at Bodhgaya S/s and relay upgradation work for configuring Disturbance Recorder, BSPTCL updated that they had taken up the issue with their higher authority.

Regarding review of backup overcurrent settings of all ICTs, BSPTCL informed that they would review the settings soon.

PCC advised BSPTCL to review the ICT backup protection settings at Bodhgaya S/s at the earliest and the settings may be shared with Powergrid so that zone 3 settings at Gaya end can be coordinated properly.

ITEM NO. D.2: Total Power Failure at Sonenagar S/S on 20/05/2021 at 03:41 Hrs

At 03:41 hrs, 220 kV Chandauti-Sonenagar D/C tripped from Chandauti end. This has led to total power failure at 220/132 kV Sonenagar (BSPTCL) and radially connected 132 kV substations. At the same time 132 kV Sonenagar – Japla S/C also got tripped.

Relay Indications :

Time	Name	End 1	End 2	PMU Observation
03:41 Hrs.	220 kV Chandauti - Sonenagar - 1	B-N, Zone 2. 76.2km, 0.7 kA	Did not trip	Around 4 kV dip has been observed in B phase voltage at Gaya PMU. Fault clearing time was around 500 ms.
	220 kV Chandauti - Sonenagar - 2	B-N, Zone 2. 76.2km, 0.7 kA	Did not trip	
	132 kV Sonenagar – Japla S/C	B-N, Directional O/C, E/F, I _B - 3.170 KA	Yet to be received	

Load Loss : 92 MW

Outage Duration : 00:42 Hrs

In 103rd PCC Meeting, BSPTCL informed that there was a B-phase to ground fault in 132 kV Sonenagar(old)- Japla S/C. Backup overcurrent protection operated from both the end. At the same time, 220 kV Chandauti-Sonenagar(new) D/C got tripped from Chandauti end in 500 msec in zone-2 of distance protection.

BSPTCL explained that distance protection relay for 132 kV Sonenagar-Japla line at Sonenagar end was found to be faulty and the same would be replaced soon. They added that after this incident, they had enabled high set in backup O/C relay with delay of 60msec as an interim measure till the time new distance relay is being installed.

Regarding non-operation of relay for 132 kV Sonenagar(new)-132 kV Sonenagar(old)lines, they pointed out that the line length is 0.5 km only. Further they informed that high set has been enabled for both the ends of this line with 100 msec delay after this incident.

PCC opined that 220/132 kV ICTs at Sonenagar(new) should have cleared the fault in case of delayed clearance of fault in 132 kV downstream and advised BSPTCL to check the ICT backup protection settings as well as the relay healthiness. The settings may be reviewed and coordinated properly.

Regarding tripping of 220 kV Chandauti – Sonenagar circuits from Chandauti end, PCC advised Powergrid to check the reach settings of distance relay at Chandauti end.

ERLDC pointed out that in various tripping incidences it has been observed that carrier is not sent from Sonenagar to Chandauti end which resulted in delayed tripping from remote end. PCC advised BSPTCL to check and resolve carrier related issue at Sonenagar end.

BSPTCL and Powergrid may update.

Deliberation in the meeting

BSPTCL updated that the distance relay at Sonenagar end for 132 kV Sonenagar-Japla line would be replaced within a week.

Regarding tripping of 220 kV Chandauti – Sonenagar circuits from Chandauti end, it was informed that impedance values in the relay at Chandauti end was set with wrong value which resulted in relay overreach and tripping of these circuits during the above disturbance.

BSPTCL further intimated that there was no carrier related issues at Sonenagar end.

ITEM NO. D.3: Total Power Failure at Joda(OPTCL) S/S on 23/05/2021 at 10:17 Hrs

On 23-05-2021 at 10:15 Hrs., all 220 kV feeders connected to 220/132 kV Joda S/S got tripped

due to operation of bus bar protection. This led to total power failure at 220/132 kV Joda and 220 kV TSIL S/S and loss of 100 MW load.

After investigation, it was found that Y-phase CT of 220 kV Joda –TSIL feeder blasted at Joda end. The power at Joda substation was restored at 11:07 Hrs. by extending power from 220 kV JSPL substation through 220 kV Joda-JSPL Line.

In 103rd PCC , OPTCL informed that there was a bus fault at 220 kV Joda S/s due to blasting of Y-phase CT of 220 kV Joda –TSIL feeder at Joda end. They added that bus bar protection operated and all 220 kV feeders connected to 220 kV Bus got tripped from Joda end.

They further clarified that the fault was cleared in 74 msec as per DR analysis. However, high current was observed in the relay of 220 kV Joda-TSIL feeder upto 130 msec due to infeed from TSIL end.

They informed that though direct trip command was sent to TSIL end, the breaker at TSIL end might have opened with a delay which resulted in current feeding from TSIL end till 130 msec. They submitted that the issue has been taken up with TSIL for detailed checking of the PLCC and other trip circuits at TSIL end.

On query regarding sending of direct trip command to remote end on operation of bus bar protection, OPTCL replied that as per their settings if breaker of a particular feeder is open and infeed current is sent from remote end then direct trip signal would be sent. Therefore, in the present instance, direct trip signal was send only to TSIL end and not for other 220 kV feeders.

Regarding non-availability of sequence of events at ERLDC SCADA system, they informed that the issue had already been communicated to their SCADA wing to resolve the issue.

OPTCL may update.

Deliberation in the meeting

Regarding non-availability of sequence of events at ERLDC SCADA system, OPTCL informed that except 220 kV Joda – Ramchandrapur line and ATR, all other elements at Joda are communicating to ERLDC. The remaining issue would be resolved at the earliest.

Regarding carrier issue at TSIL, they informed that it had been communicated to TSIL and thorough checking & testing of PLCC and trip circuits would be done at TSIL end after getting line shutdown of this circuit.

ITEM NO. D.4: Disturbance at Rengali S/s on 28/05/2021 at 07:45 Hrs

Due to CVT failure of 220 kV Rengali-TSTPP S/C at Rengali end, all 220 kV lines connected to 220 kV Rengali (OPTCL) S/S and 220 kV Rengali PH got tripped. Y phase jumper snapping of 220 kV Rengali-Rengali – 2 at 220 kV Rengali (OPTCL) Bus A was also reported at the same time.

The event has led to total power supply failure at 220 kV Rengali Hydropower station and 220 kV Rengali (OPTCL) S/s.

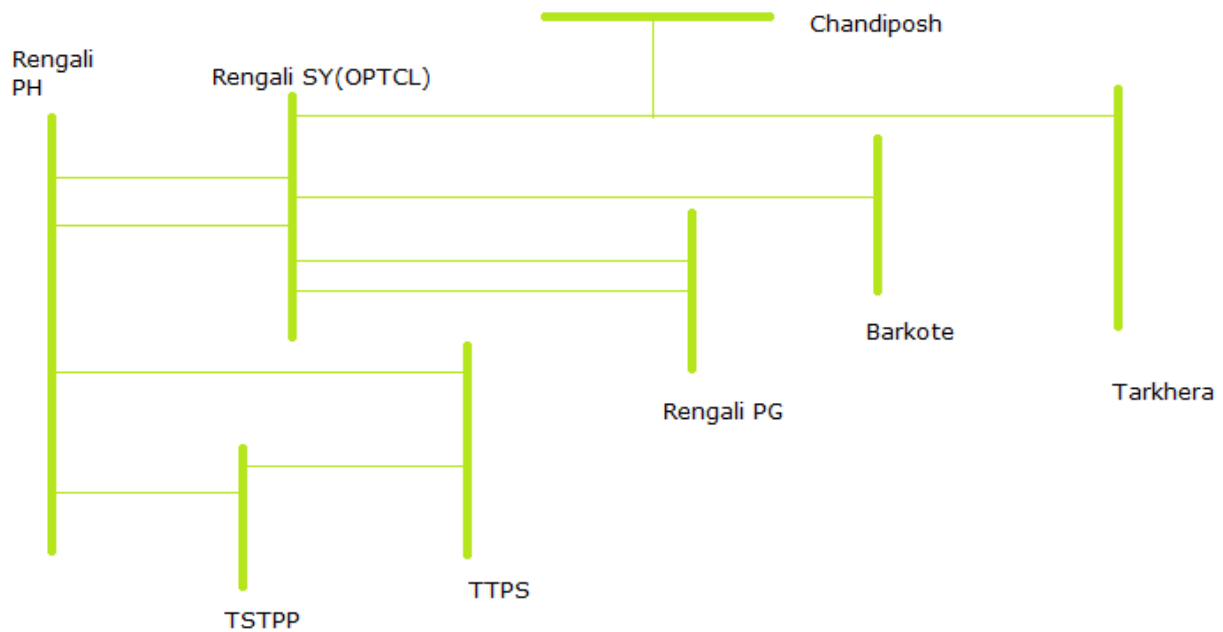

In 103rd PCC , OPTCL explained that the fault occurred due to jumper snapping of Y-phase of 220 kV Rengali(OPTCL)- Rengali (PG)-2 line at Bus A of Rengali(OPTCL) switchyard resulting in a bus fault.

The following elements were tripped to clear the fault:

Name	End 1	End 2
220 kV Rengali(OPTCL)-Rengali PG-1	Backup protection operated	Did not trip
220 kV Rengali(OPTCL)-Rengali PG-2	Did not trip	Zone-1
220 kVRengali(OPTCL)-Barkote	Did not trip	Zone-2, F.D-49.7kM
220 kVRengali(OPTCL)-Tarkera	Did not trip	Zone-2, F.D-141 kM
220 kVRengali(OPTCL)-Rengali PH-I	Did not trip	Did not trip
220 kVRengali(OPTCL)-Rengali PH-II	Zone-4 picked up	Did not trip
220 kV Rengali PH- TSTPP	Did not trip	Zone-3
220 kV Rengali PH- TTPS	Did not trip	Tripped from TTPS end

They informed that being an old substation, busbar protection was not available at 220 kV Rengali(OPTCL) end.

It was informed that due to CVT failure of 220 kV Rengali PH -TSTPP S/C line at Rengali PH end, relay at Rengali PH end was unable to sense the fault and hence the 220 kV Rengali – TSTPP S/C tripped in zone 3 from TSTPP end.

The tripping detail at TTPS end for 220 kV Rengali PH-TTPS line was not available.

The reason for non-operation of any protection system at Rengali PH end could not be explained in absence of any DR/EL or report from OHPC. OHPC representative was not available in the meeting.

PCC expressed serious concern for non-submission of relevant details for analyzing the grid disturbance and advised SLDC Odisha to collect all the details and submit a report for this disturbance at the earliest.

PCC advised OPTCL to review zone-4 settings for 220 kV Rengali(OPTCL)-Rengali PH lines at OPTCL end so that in case of any bus fault at 220 kV Rengali(OPTCL) end the same can be cleared at minimum time.

PCC also advised OPTCL to implement busbar protection at 220 kV Rengali(OPTCL) at the earliest.

OPTCL may update.

Deliberation in the meeting

SLDC Odisha informed that disturbance report had been submitted to ERPC/ERLDC. It was observed from the report that there was no tripping at Rengali PH end during the disturbance. Also the zone-4 timing had been set at 1200msec for all the relays. As a result 220 kV Rengali PH-TSTPP line & 220 kV Rengali PH-TTPS line got tripped from remote end in zone-3 protection before tripping of the lines at Rengali end.

PCC advised OHPC to revise the zone-4 settings of all the lines at their end as per the ERPC protection philosophy. PCC also advised to review the settings of 220 kV Rengali PH-Rengali(OPTCL) lines at their end.

OPTCL informed that they had revised zone-4 time settings for 220 kV Rengali – Rengali PH lines to 250 msec at OPTCL end.

Regarding commissioning of Bus bar protection at Rengali(OPTCL) end, they informed that they had taken up the issue with their higher authority.

ITEM NO. D.5: Total Power Failure at Dumka S/s on 15/05/2021 at 12:01 Hrs

Due to tower collapse of 220 kV Farakka-Lalmatia S/C in April 2021, local load at 220 kV Dumka and Godda S/S were being radially fed from 400/220 kV Maithon S/S through 220 kV Maithon-Dumka D/C and 220 kV Dumka-Godda D/C. 220 kV Maithon-Dumka-1 was under shutdown for attending the hotspot at connector of R-phase pole circuit breaker of the line.

At 12:02 hrs 220 kV Maithon Dumka – 2 tripped on R phase to earth fault resulting in total power failure at Goda, Dumka S/S and nearby areas.

In 103rd PCC , JUSNL informed that a shutdown was availed for 220 k V Maithon – Dumka circuit-1 on 15/05/2021 at 10:45 hrs for attending hotspot at connector of R-phase pole circuit breaker of the line. At 12:02 hrs, 220 kV Maithon – Dumka circuit-2 tripped on R-N fault in zone 1 protection from both the end. The fault distance was 23 km from Dumka end.

Regarding non-operation of autorecloser of the line, Powergrid informed that though autorecloser is enabled for the line, the same is not operating due to issues in PLCC. They further clarified that the issue has been communicated to JUSNL several times, however the same has not been resolved yet. They added that there was no formal O&M agreement by JUSNL with Powergrid for maintenance of bay equipment at Maithon end.

PCC opined that at present 220 kV Maithon-Dumka D/C line is the primary and main source for power supply to Dumka/Lalmatia area of Jharkhand and tripping of this line results into huge load loss every time. PCC raised serious concern on non-availability of autorecloser in the line and lack

of proper maintenance of the line.

PCC advised JUSNL to take immediate steps to rectify the autorecloser issue in the line and referred the issue to forthcoming OCC meeting for further discussion.

JUSNL may update.

Deliberation in the meeting

Regarding PLCC issue, Powergrid informed that carrier was not being received from Dumka end & the issue needs to be resolved by JUSNL.

JUSNL stated that OEM of the PLCC had already been communicated in this regard however they are yet to receive any communication from them.

PCC expressed serious concern for delay in resolving the PLCC issue for 220 kV Maithon-Dumka lines and advised JUSNL to take up this issue on priority & resolve the same at the earliest.

ITEM NO. D.6: Disturbance at Jasidih(JUSNL) S/S on 27/05/2021 at 10:13 Hrs

On 27-05-2021, demand in Jharkhand system was low because of thunderstorm and heavy rainfall caused by Cyclone Yaas. This had resulted in high voltage at various parts of JUSNL network.

At 03:22 hrs, 220 kV Dumka-Jasidih D/C were hand tripped at Dumka end because of overvoltage. Charging of 220 KV Dumka-Jasidih – 1 was attempted at 03:51 Hrs and 07:01 Hrs and finally it was charged at 09:50 Hrs.

At 10:13 hrs, 220 kV Dumka Jasidih – 1 tripped from Dumka end due to operation of overvoltage stage 1. With this 132 kV Dumka – Dumka D/C and 132 kV Dumka – Deoghar D/C also got tripped. This has led to loss of supply at 220/132 kV Jasidih and 132 kV Dumka substation.

In 103rd PCC meeting, JUSNL informed that on 27/05/2021 demand of Jharkhand system was low because of thunderstorm and rainfall caused by Yaas cyclone. This resulted in overvoltage at various parts of JUSNL network due to which at 10:13 hrs, 220 k V Dumka- Jasidih -1 tripped from Dumka end due to overvoltage protection stage 1 and simultaneously 132 kV Dumka – Dumka D/C and 132 kV Dumka – Deoghar D/C also tripped in overvoltage protection from Dumka end.

JUSNL further informed that overvoltage protection was enabled for all 132 kV S/S which were commissioned/renovated under PSDF project, however as per advice of ERLDC, they had disabled overvoltage protection at these Substations.

PCC advised JUSNL to disable O/V protection in all 132 kV lines in their system.

Regarding overvoltage protection settings in 220 kV lines, JUSNL informed that the same has been enabled for some of the selected lines and the settings are uniform across all the lines.

PCC opined that in case the O/V protection has been enabled for 220 kV lines, time grading as well as voltage grading shall be followed for parallel lines emanating from a substation to avoid simultaneous tripping of the lines.

PCC enquired about philosophy for overvoltage protection settings for 220 kV level lines being followed by ER utilities to which the utilities responded as follows:

- *Powergrid, DVC, WBSETCL & OPTCL informed that overvoltage settings are not enabled at 220 kV level for their systems.*
- *BSPTCL informed that O/v settings have been enabled in some of the selected substations where overvoltage are being observed.*

- *CESC informed that the voltage at 220 kV level can be controlled through changing the ICT taps and opined that O/V settings is not required at 220&132 kV level.*

Based on the feedback of all utilities, PCC observed that in general overvoltage settings is not required at 220 kV level and the same may be enabled on case to case basis depending on the local voltage condition.

PCC advised JUSNL to develop a philosophy for overvoltage settings at 220 kV level for their system in line with the above discussion. In case they decide to enable O/V setting in some of the lines, the list of such lines along with proposed settings may be submitted to ERPC/ERLDC.

JUSNL may update.

Deliberation in the meeting

JUSNL informed that they are in process of developing a philosophy for overvoltage settings at 220 kV level for their system and the same would be submitted to ERPC and ERLDC as soon as the report gets finalised.

ITEM NO. D.7: Total Power Failure at Khagaria(BSPTCL) S/S on 27/05/2021 at 23:22 Hrs

220 kV Khagaria S/S is radially connected to New Purnea S/S through 220 kV Khagaria-New Purnea-2. On 27-05-2021, demand in Bihar was low because of thunderstorm and heavy rainfall due to depression caused by Cyclone Yaas.

At 23: 22 hrs, 220 kV Khagaria-New Purnea-2 tripped due to Y-B fault resulting in total power failure at Khagaria S/S. Power supply restored at 00:50 hrs.

In 103rd PCC Meeting, BSPTCL informed that on 27/05/21 the demand of Bihar System was low due to thunderstorm and heavy rainfall. At 23:22 hrs, 220 kV Khagaria-New Purnea tripped from New Purnea end in zone 1 protection due to Y-B phase to phase fault. They added that as Khagaria was radially connected from new Purnea end, there was no tripping from Khagaria end.

ERLDC informed that 220 kV New Purnea-Khagaria-2 has been tripped multiple times in the month of May'21 and in all the incidents, there was phase to phase fault with same location which indicates sag or clearance issue.

BSPTCL submitted that patrolling was being carried out by the concerned team and shutdown of the line has been planned to solve the clearance and sag related issue.

PCC advised BSPTCL to resolve the clearance issue in concerned location and submit a report to ERPC and ERLDC.

BSPTCL may update.

Deliberation in the meeting

BSPTCL informed that patrolling was carried out in the concerned section of the line and no sag issue was identified. However, clearance issue related to vegetation was found in some of the locations which had been resolved.

ITEM NO. D.8: Bus tripping occurred in Eastern Region during May 2021

During May 2021, following incidents of bus bar tripping have been observed in Eastern Region.

Element Name	Tripping Date	Reason	Revival Date & time
400 kV Main bus - 2 at Teesta V	17-05-2021 at 18:08 Hrs.	Unit 3 at Teesta-V was synchronized with the grid at 18:04:30 hrs and load was raised up to around 40 MW. Unit#1 and Unit#2 were already running at full load. At 18:08:13 hrs, 400 kV Teesta V - Rangpo - 2 (tripped only from Teesta V end), Unit#3 and Bus coupler Circuit Breakers at Teesta V tripped simultaneously due to operation of bus bar protection at Teesta V. Fault was in B phase and Fault current was around 11 kA. Fault clearing time was less than 100 ms.	20-05-2021 at 00:01 Hrs.

In 103rd PCC Meeting, the event could not be discussed as Teesta-V(NHPC) representative was not available in the meeting.

It was decided to communicate the issue to NHPC for submission of necessary details related to the above tripping.

NHPC may update.

Deliberation in the meeting

NHPC intimated that during synchronization of Unit #3 with the grid, flashover occurred at Grading Capacitor of Y-phase CB of Unit#3. This resulted in a bus fault and operation of bus bar protection for 400 kV bus-2 at Teesta V. All the elements connected to Bus-2 got tripped along with Unit#3

They further informed that the issue was rectified after the event.

ITEM NO. D.9: Repeated Tripping of 220 kV Daltonganj-Garwah (New) D/C in the month of April' 21.

In 103rd PCC Meeting, JUSNL informed that remaining pending work related to line maintenance of 220 kV Daltonganj-Garwa D/C lines have been completed and no further tripping had been observed in the line.

PCC enquired about enabling permissive overreach protection at 220 kV Daltongunj end for 220 Daltonganj-Garwah line.

Powergrid replied that the same had been communicated to Substation for implementation as soon as possible.

Powergrid may update.

Deliberation in the meeting

Powergrid informed that permissive overreach protection had been enabled for 220 kV Daltonganj-Garwah D/C lines at Daltonganj end.

ITEM NO. D.10: Disturbance at 220 kV Tashiding S/s on 16.04.2021 at 16:46 hrs

At 16:46, 220 KV New Melli- Tashiding tripped on 3-phase fault. At the same time, 220 KV Rangpo-Tashiding also tripped from Rangpo end on 3-phase fault isolating 220 KV Tashiding station. There was no generation loss as Tashidig had no schedule at that time.

Frequent faults are being observed in this corridor, resulting in station blackout and generation loss, hence proper line patrolling, maintenance needs to be ensured

In 103rd PCC Meeting , following deliberations took place –

Regarding removal of LILO connection of 220 kV Rangpo-N.Melli line at Tashiding, Powergrid updated that commissioning work related to PLCC panel is pending at New Melli end. The same would be completed after visit of OEM engineers to the site. Thereafter necessary reconfiguration of 220 kV N.Melli-Tashiding circuits at N. Melli end would be completed subject to necessary shutdown approval from Tashiding HEP.

PCC advised Powergrid to complete the work in coordination with Tashiding HEP.

Powergrid&Tashiding HEP may update.

Deliberation in the meeting

Powergrid informed that the PLCC work had not yet been completed as the OEM engineers could not visit the substation due to Covid situation. They further informed that to complete all the pending works related to proposed reconfiguration, they need continuous shutdown of both the circuits connected to Tashiding HEP for 2 days.

Tashiding HEP stated that due to ongoing high hydro period, it is difficult to arrange the required shutdown and suggested to avail the shutdown after the peak hydro season i.e. in October'21.

PCC advised Powergrid to avail the required shutdown after high hydro period.

ITEM NO. D.11: Total power failure at 400 kV Teesta–III Substation on 23.04.2021 at 13:21 hrs

At 13:21 Hrs, 400 kV Teesta-3-Kishangunj tripped on B-N fault and at the same time 400 kV Teesta-3 -Dikchu also tripped on same fault . As a result, around 148 MW generation loss occurred at Teesta-III due to loss of evacuation path. There was no generation at Dikchu.

In 103rd PCC Meeting following deliberations took place –

It was decided that PRDC would do revised study for DEF relay settings considering the existing zone-3 settings at Kishanganj end and share it with concerned utilities.

PCC advised Powergrid and Dikchu to implement the revised settings for DEF relay at their end in order to have a proper coordination among the relays.

Powergrid & Dikchu HEP may update.

Deliberation in the meeting

PCC advised PRDC to share the revised settings to Powergrid and Dikchu for implement of the same at their end.

ITEM NO. D.12: Disturbance at 220 kV Budhipadar S/s at 13:47 Hrs on 08.04.2021.

220 KV Budhipadar-Lapanga ckt-1&2 tripped at 13:47 and 13:49 hrs respectively, followed by tripping of Budhipadar-Raigarh on 14:03 hrs, due to B phase fault.

At increased loading of Tarkera D/C , circuit-1 also developed B phase fault at 14:06:27 Hrs and tripped .

At 14:07:24 Hrs bus fault was created at Bus-1 (with snapping of R-Ph pipe bus from isolator to Breaker of 220KV Budhipadar- Tarkera Ckt-2). All the remaining feeders with Bus -1 tripped.

With all evacuating sources out ,IBTPS and Vedanta,Bhusan formed Island with its own CPP load but due to excess generation of approx. 560 MW (Vedanta=250, IB=250 , Bhusan=50, pre event exchange with grid) over frequency occurred and also all generators tripped on Over frequency .

In 103rd PCC Meeting , OPTCL informed that the study had been completed and the report would be shared to ERPC/ERLC within a week.

PCC advised SLDC Odisha to coordinate with Vedanta for submission of report for unsuccessful islanding at Vedanta CPP during the disturbance on 08/04/21.

*OPTCL vide letter dated 29/06/2021 had submitted the study report for intrastate constraints in Odisha system in Budhipadar command area. The report is enclosed at **Annexure D.12***

OPTCL & Vedanta may update.

Deliberation in the meeting

PCC observed that the report submitted by OPTCL suggests for establishing a new line as a long term measure to reduce constraints in the Budhipadar command area, however there is no suggestion regarding short term measures to comply with n-1 reliability criteria at Budhipadar S/s.

OPTCL suggested that as representative from their system study wing is not available in the meeting, the issue may be placed for discussion in forthcoming OCC meeting.

The issue was referred to OCC for further deliberation.

ITEM NO. D.13: Grid event at 132 k V Motihari (DMTCL) S/S on 21-04-2021 at 20:19 hrs

On 21st April 2021 at 19:00 hrs, 132 kV side of 400/132 kV 315MVA ICT-3 (Ownership is with PowergridMithilanchal Transmission Ltd) at Motihari was being charged through 132 kV GIS Bus 1. Just after charging of new ICT, 132kV Main bus-1 at Motihari tripped due to Bus extension module SF6 gas pressure low trip at 19:01 Hrs. Following feeders which were connected with 132kV Main bus – 1 at Motihari tripped:

- 132 kV side of 400/132 kV ICT – 1 at Motihari
- 132 kV Betiya – 1
- 132 kV Motihari – 1
- 132 kV Raxaul – 1

In 103rd PCC Meeting , Powergrid informed that to find out the root cause of the incident, both the OEMs involved in GIS system at Motihari were discussing with each other. Also, a joint investigation of affected GIS module at Motihari (DMTCL) in presence of both the OEM engineers is to be planned after getting shutdown consent from SLDC, Bihar. The report would be submitted after the investigation.

DMTCL informed that 132 kV bus along with 132 kV Motihari – Raxaul-2 can be restored after assessing the damage in the GIS system during the proposed joint inspection by OEM engineer.

PCC advised Powergrid to coordinate with DMTCL & SLDC Bihar for getting the necessary shutdown at Motihari S/s to carry out the inspection by OEM engineers.

DMTCL, & Powergrid may update.

Deliberation in the meeting

DMTCL informed that their OEM engineers had visited the site and assessed the damage at DMTCL portion. It was found that isolator of 132 kV Raxaul-1 circuit with 132 kV bus-1 got damaged. They informed that both 132 kV bus-1 & bus-2 at DMTCL were charged after separating the damaged bus extension portion. Also all the 132 kV lines at DMTCL including 132 kV Motihari-Raxaul-2 had been restored. However both the 132 KV Raxaul circuits were connected to main bus-2 only. The report by their OEM had been forwarded to Powergrid also.

Regarding investigation of affected GIS module at Motihari (DMTCL), it was informed that visit of other OEM i.e. M/s Hyosung had been scheduled in this week. After completion of this visit, report would be submitted by PMTL.

MS, ERPC informed that several communications had been received from CEA regarding the above incident on 21/04/2021. He advised PMTL to expedite the investigation and share the final report at the earliest.

ITEM NO. D.14: Tripping of 400/220 kV Biharshariff ICT-1,2 &3 on 03-04-2021 at 19:45 hrs

On 03-04-2021 at 19:45 hrs, 400/220 kV ICT 1,2&3 tripped due to R phase CT blast of ICT-2 at 220 kV side. 220 kV Biharshariff-Khezesarai D/C also got tripped.

ICT 1&2 tripped from Powergrid side and Inter-trip sent to BSPTCL end while ICT-3 tripped from only BSPTCL side. ICT-4 was in service with loading of 350 MW. Biharshariff-Khezesarai D/C tripped from Khezesarai end on Zone -2 from Khezesarai end. There is no Bus bar scheme at Present at 220 k V Biharshariff.

In 103rd PCC Meeting, BSPTCL updated as follows:

- The shutdown has been planned for ICT-2 on 18th June 2021 for thorough checking of cables/wirings between HV and LV side of the ICTs.
- Regarding configuring of disturbance recorder of the relays for LV side of ICTs, they stated that since the relays are of new make and model, they had contacted with OEM for necessary configuration.
- Regarding status of busbar protection, they informed that the wiring for busbar panel had been completed for some of the bays. However, the work has been stopped due to Pandemic situation.

Regarding tripping of 220 kV Biharshariff-Khezesarai D/C from Khezesarai end, BGCL informed that the tripping was due to wrong settings in the relay and the same had been rectified.

BSPTCL may update.

Deliberation in the meeting

Regarding simultaneous tripping of multiple ICTs, BSPTCL updated as follows:

- *Tan-delta test of CTs installed at LV of ICT 1 had been performed and results were satisfactory except of R-phase CT for which communication had been done with OEM to replace R – phase CT.*
- *CT secondary injection test of R, Y and B phases of ICT 1 and ICT 2 were done and no discrepancy was found.*
- *Y – phase mechanism box of ICT1 was found defective and had been replaced .*
- *Breaker time test for R, Y and B phases was done and results were satisfactory.*

They further informed that for detail checking of cable/ wiring between HV and LV side of ICTs, shutdown of ICTs has been planned on 14.07.2021 and 15.07.2021 .

Regarding status of busbar protection, they informed that they have taken up the issue with their higher authority for expediting the commissioning work.

ITEM NO. D.15: Repeated delayed clearance of faults at 220 kV Chandil STPS S/C

In March 2021, 220 kV Chandil STPS S/C tripped repeatedly due to various short circuit faults at 6-12 km from STPS.

In 103rd PCC Meeting , JUSNL informed that they have taken up the issue with OEM for through checking of PLCC panel at Chandil end. The OEM visit is expected in first week of July'21.

PCC advised JUSNL to expedite the process to resolve the PLCC issue at Chandil end.

JUSNL may update.

Deliberation in the meeting

JUSNL informed that OEM visit has been rescheduled to 3rd week of July'21.

ITEM NO. D.16: Total Power Failure at 400 kV Motihari Substation on 21.01.2021 at 11:20 hrs

400 kV Motihari-Gorakhpur D/C and 400 kV Motihari Barh-1 were out of service due to tower collapse. Motihari was connected to rest of the grid through 400 kV Barh-Motihari - 2. On 21-01-2021 at 11:20 hrs, a transient Y-phase to earth fault occurred at 400 kV Barh-Motihari - 2. Successful auto reclose operation was occurred at Motihari end.

In 103rd PCC Meeting , NTPC informed that they had not received any communication from their engineering wing.

PCC expressed serious concern for delay in getting the confirmation from engineering wing of NTPC and advised NTPC to expediate the issue with their corporate for expediting the process.

NTPC may update.

Deliberation in the meeting

NTPC intimated that they had received revised settings from their engineering wing. The settings would be implemented by availing shutdown of the element.

Annexure A

LIST OF PARTICIPANTS IN 104TH PCC MEETING HELD ON 13.07.2021 (TUESDAY) THROUGH MS TEAMS ONLINE MEETING PLATFORM

Full Name	Join Time	Email
ERPC Kolkata	7/13/2021, 10:15:53 AM	ERPC@KolkataMST.onmicrosoft.com
rajendra prasad (Guest)	7/13/2021, 10:16:13 AM	
Aishwary Shukla	7/13/2021, 10:26:20 AM	
Alok Pratap Singh ,ERLDC (Guest)	7/13/2021, 10:26:20 AM	
D K Bauri, ERPC (Guest)	7/13/2021, 10:26:21 AM	
Akhand Pratap	7/13/2021, 10:26:21 AM	
SLDC ODISHA (Guest)	7/13/2021, 10:26:21 AM	
M K Kirtania ER-2 (Guest)	7/13/2021, 10:26:22 AM	
Sudipta ranjan Nayak	7/13/2021, 10:26:30 AM	
POWERGRID ER-1 (Guest)	7/13/2021, 10:27:09 AM	
Sukdev (PG) (Guest)	7/13/2021, 10:27:10 AM	
Debdas Mukherjee WBPDC	7/13/2021, 10:27:12 AM	
Sonam Wongchuk(SIKKIM SLDC) (Guest)	7/13/2021, 10:27:21 AM	
Rajib Sutradhar	7/13/2021, 10:28:49 AM	rajib@posocoshillong.onmicrosoft.com
Jitendra Kumar, GM, Teesta-V (Guest)	7/13/2021, 10:29:13 AM	
Saurav Kumar Sahay ERLDC	7/13/2021, 10:29:21 AM	
RAHUL BANSAL	7/13/2021, 10:29:47 AM	RAHULBANSAL@NTPC.CO.IN
Ganesh Korada	7/13/2021, 10:29:56 AM	ganesh.korada@opgc.co.in
DGM CRITL JUSNL	7/13/2021, 10:30:00 AM	
Arindam BSPTCL	7/13/2021, 10:30:24 AM	
Vijayanand Semletty	7/13/2021, 10:30:31 AM	Vijayanand.Semletty@SEKURA.IN
MS ERPC (Guest)	7/13/2021, 10:30:36 AM	
Raj Protim ERLDC (Guest)	7/13/2021, 10:30:45 AM	
Prachi Gupta	7/13/2021, 10:31:01 AM	
R.L.PASWAN, GM TZ-II, DUMKA	7/13/2021, 10:31:07 AM	
Sucharit Mondal	7/13/2021, 10:31:15 AM	
SMS SAHOO,DGM,OPTCL,BHUBANESWAR	7/13/2021, 10:31:16 AM	
Rahul Anand	7/13/2021, 10:31:40 AM	RAHULANAND@NTPC.CO.IN
Rakesh Oraon	7/13/2021, 10:31:58 AM	
Rakesh	7/13/2021, 10:32:08 AM	
Prasanna Kumar Sahoo	7/13/2021, 10:32:09 AM	PRASANNASAHOO@NTPC.CO.IN
Deepak, EEE, BSPTCL	7/13/2021, 10:32:13 AM	
Dilip kant Jha Eee Bsptcl	7/13/2021, 10:32:17 AM	
U K MISHRA (Guest)	7/13/2021, 10:32:57 AM	
Chandan Kumar	7/13/2021, 10:33:05 AM	admin@POSOCO965.onmicrosoft.com
Saibal Ghosh,ERLDC (Guest)	7/13/2021, 10:33:52 AM	
Nishant Kumar Shankwar	7/13/2021, 10:34:05 AM	Nishant.Kumar@SEKURA.IN
Ch Mohan Rao,PGCIL, Odisha	7/13/2021, 10:34:15 AM	
Pankaj Mishra Critl Bsptcl	7/13/2021, 10:34:23 AM	
Satyapriya Behera	7/13/2021, 10:34:25 AM	satyapriya.behera@opgc.co.in
Sourav Biswas, Dy. Manager, ERLDC (Guest)	7/13/2021, 10:34:28 AM	
GAGAN KUMAR EEE SLDC	7/13/2021, 10:34:50 AM	
saaurabh (Guest)	7/13/2021, 10:34:52 AM	
Vanrajsinh Dodia	7/13/2021, 10:35:04 AM	Vanrajsinh.Dodia@sekura.in
shadab hasan	7/13/2021, 10:35:12 AM	
\\\\"\\\\"\\\\"\\\\"madan mohan (Guest)\\\\"\\\\"	7/13/2021, 10:35:37 AM	
Pritam Goswami	7/13/2021, 10:35:37 AM	pritam.g@tvptl.com
DILSHAD ALAM	7/13/2021, 10:35:57 AM	
Sudipta ranjan Nayak	7/13/2021, 10:36:47 AM	
Neeraj Kumar Verma	7/13/2021, 10:36:58 AM	Neeraj.Verma@SEKURA.IN
Rahul kumar	7/13/2021, 10:37:42 AM	
s choudhary	7/13/2021, 10:37:51 AM	
ERLDC BILASH (Guest)	7/13/2021, 10:38:54 AM	
DEEPAK THAKUR	7/13/2021, 10:39:25 AM	
S K Das, NHPC	7/13/2021, 10:39:30 AM	admin@NHPC170.onmicrosoft.com
S Gautam(Chuzachen) (Guest)	7/13/2021, 10:39:56 AM	
Uma Kanta Mishra	7/13/2021, 10:40:18 AM	
SLDC,Ranchi (Guest)	7/13/2021, 10:40:20 AM	
Vinay Kumar Kishku	7/13/2021, 10:40:32 AM	
pritam mukherjee	7/13/2021, 10:41:02 AM	
CE CTD	7/13/2021, 10:41:08 AM	admin@WBSETCL570.onmicrosoft.com
sk	7/13/2021, 10:41:14 AM	
EMR Meramundali	7/13/2021, 10:43:43 AM	
Rajiv	7/13/2021, 10:45:45 AM	
EEE /critl	7/13/2021, 10:46:38 AM	
kundan Kumar	7/13/2021, 10:46:42 AM	
SR. Mohapatra	7/13/2021, 10:47:05 AM	
BIHAR GRID COMPANY	7/13/2021, 10:47:22 AM	admin@bgcl710.onmicrosoft.com
jitesh kumar (Guest)	7/13/2021, 10:48:01 AM	
rRajiv Kumar Singh	7/13/2021, 10:48:21 AM	

Rambaboo Singh (Guest)	7/13/2021, 10:49:37 AM	
eee critl	7/13/2021, 10:51:49 AM	
Lenin, EE(Guest)	7/13/2021, 10:52:03 AM	
Kishore Chandra Bhoi	7/13/2021, 10:53:09 AM	
Bauribandhu Behera	7/13/2021, 10:54:23 AM	bauribandhu.behera@opgc.co.in
abhinaba basu	7/13/2021, 10:54:43 AM	
Praveen(PRDC)	7/13/2021, 10:56:26 AM	
rupa	7/13/2021, 10:56:28 AM	
Debajyoti ERLDC (Guest)	7/13/2021, 10:56:47 AM	
suraj	7/13/2021, 10:57:51 AM	
CRITL	7/13/2021, 11:00:31 AM	
Deepak Vinnakota (Guest)	7/13/2021, 11:00:42 AM	
Binod Sahoo	7/13/2021, 11:01:57 AM	binod.sahoo@opgc.co.in
manish kumar	7/13/2021, 11:02:02 AM	
Amlan Avijit Nanda	7/13/2021, 11:03:01 AM	215619@vedanta.co.in
Manager CRITL JUSNL (Guest)	7/13/2021, 11:03:43 AM	
Kishore Chandra Bhoi	7/13/2021, 11:05:04 AM	
Prince kumar	7/13/2021, 11:07:58 AM	
CRITL, JUSNL (Guest)	7/13/2021, 11:10:01 AM	
Deepak Kumar Singh (Guest)	7/13/2021, 11:10:09 AM	
SANJEEV KUMAR (Guest)	7/13/2021, 11:10:33 AM	
Aee bsptcl	7/13/2021, 11:12:44 AM	

**Report on Tripping at 400/220/132 kV Chandauti Sub-station on
dated 25.06.2021**

Pre-fault Condition (220kV Side):

Sr No	Feeder Name	Bus Isolator Condition	Power flow	Remarks
1	210 (Chandauti Sonenagar 1)	21089 B - Closed 21089 A - Open	Under Shutdown	(Shutdown taken by BSPTCL for line work)
2	211 (Chandauti Sonenagar 2)	21189 B - Closed 21189 A - Open	83 MW	
3	213 (400/220 kV ICT 1)	21389 A - Closed 21389 B - Open	26 MW	
4	216 (400/220 kV ICT 2)	21689 A - Closed 21689 B - Open	26 MW	
5	218 (400/220 kV ICT 3)	21889 A - Open 21889 B - Closed	26 MW	
6	214 (220 kV Bodh Gaya 2)	21489 A - Open 21489 B - Closed	00 MW	Line Charged as anti theft condition
7	215 (220 kV Bodh Gaya 1)	21589 A - Closed 21589 B - Open	00 MW	Line Charged as anti theft condition
8	209 (220/132 kV ICT 1)	20989 A - Open 20989 B - Closed	00 MW	Charged on no load condition
9	208 (220/132 kV ICT 2)	20889 A - Open 20889 B - Closed	00 MW	Charged on no load condition
10	207 (220/132 kV ICT 3)	20789 A - Closed 20789 B - Open	00 MW	Charged on no load condition
11	212 (Bus Coupler)	21289 A - Closed 21289 B - Closed	Bus Coupled through Bus Coupler	

Tripping analysis:

Incident: At 16:04:07 hrs, SOTF of Sonenagar Ckt-1, which was already under S/D has operated. After around 200 m Sec the LBB of this bay also operated and in turn 220kV Bus-2 at Chandauti SS got tripped on operation of LBB and resulted into tripping of all the elements connected with 220 kV Bus-2.

Analysis: After availing the S/D of Sonenagar Ckt-1 by M/s BSPTCL, Earth switch at both the end had been closed. For the protection of this line REL670 is used as Main-1 and Micom P444 has been used as main-2 protection.

As observed from the DR, there was a R-N fault in Sonenagar Ckt-2 at 16:04:07 hrs in Z-1 with fault current as 1.9 KA. R-pole of this line opened and this was ready for A/R operation.

Before this fault in Ckt-2, in Sonenagar Ckt-1 there was almost zero current in each R,Y & B phase and neutral of CT (primary values) during S/D condition. During this fault, the circulating current values in Ckt-1 increased up to 200-245A in each phase and 670 A in neutral. At this time the SOTF protection of Main-2 Relay operated. This in turn initiated the LBB protection and as the current was already more than the LBB pick up value the LBB operated after 200 msec. The DR records are as follows:

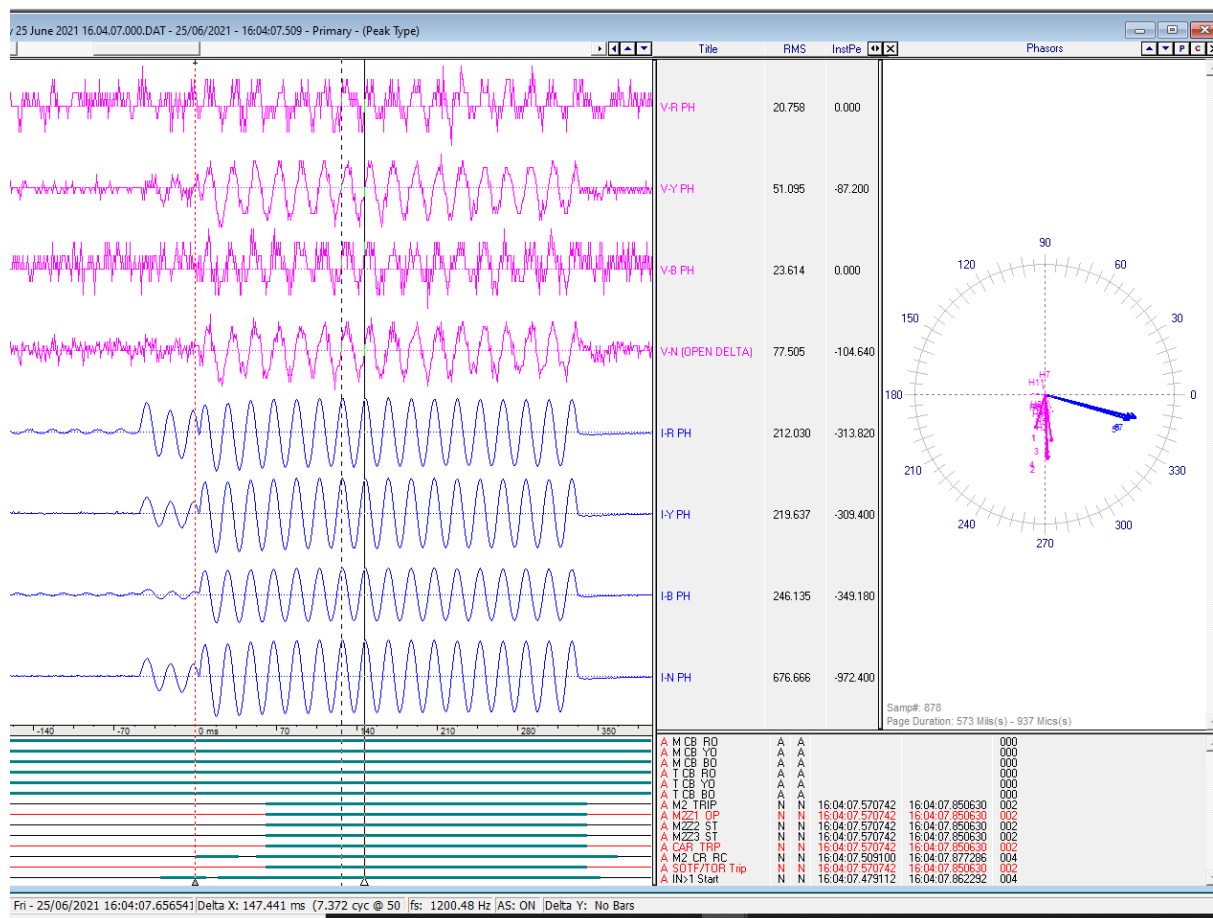

DR record of Sonenagar Ckt-1 at the time of event

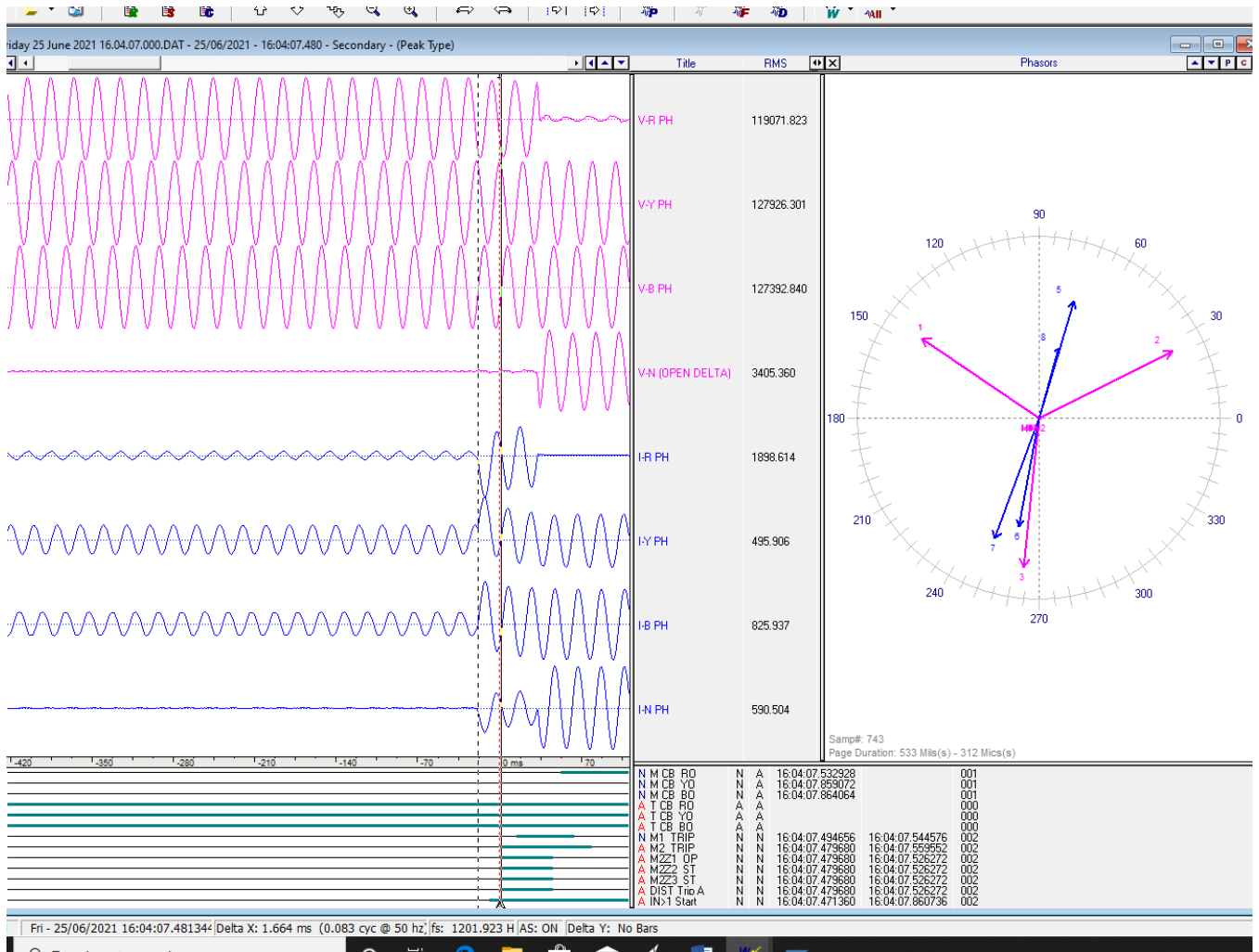

DR record of Sonenagar Ckt-2 at the time of event

Corrective Action: While going through the tripping analysis, it seems that the protection including LBB has operated as per the scheme. If Busbar had not tripped then A/R of Sonenagar Ckt-2 would have also been successful and there might have not been any tripping.

To prevent from re-occurring the incident in future, it has been directed to all the sites having DMT/DM Bus Scheme to open the Bus Isolators during S/D of any Line before closing the Line Earth switch.

Enclosures:

1. DR Main 1 & Main 2, 210 Bay
2. DR Main 1 & Main 2, 211 Bay
3. Bus Bar DR
4. 210 Bay LBB DR
5. SCADA Events

पावर सिस्टम ऑपरेशन करपोरेशन लिमिटेड

(भारत सरकार का उद्यम)

POWER SYSTEM OPERATION CORPORATION LIMITED

(A Government of India Enterprise)



Eastern Regional Load Despatch Centre: 14, Golf Club Road, Tollygunge, Kolkata-700 033.

CIN: U40105DL2009GOI188682

फ़ोन: 033- 24235755, 24174049 फ़ैक्स : 033-24235809/5029 Website: www.erldc.org, Email ID- erldc@posoco.in

घटना संख्या: 05-06-2021/1

दिनांक: 05-06-2021

Report on the grid event in Eastern Region (पूर्वी क्षेत्र में ग्रिड घटना पर रिपोर्ट)**Summary of the event (घटना का सारांश):**

At 17:10 hrs, all 220 kV lines, emanating from 220 kV Biharshariff (Bihar) tripped. It was reported that R phase CT at LV side of 400/220 kV ICT- 2 busted out resulting to tripping of all emanating lines. Total load loss was around 180 MW at Ekangasarai / Rajgir / Baripahari / Hatida / Harnaut / Barh / Nalanda in Bihar system. Entire load restored by 18:20 hrs.

- **Date / Time of disturbance:** 05-06-2021 at 17:10 hrs.
- **Event type:** GD - 1
- **Systems/ Subsystems affected:** 220/132 kV Biharshariff (Bihar) S/S.
- **Load and Generation loss.**
 - No generation loss was reported during the event.
 - Around 180 MW load loss was reported during the event (Ekangasarai, Rajgir, Baripahari, Hatida, Harnaut, Barh, Nalanda, Nawada).

Major elements tripped (प्रमुख ट्रिपिंग):

Transmission/Generation element name संचरण लाइन / विद्युत उत्पादन इकाई का नाम	Trip Date बंद होने की तिथि	Trip Time बंद होने का समय
400KV/220kV 315 MVA ICT 1 at Biharshariff	05.06.2021	17:10 hrs
400KV/220kV 315 MVA ICT 2 at Biharshariff	05.06.2021	17:10 hrs
400KV/220kV 315 MVA ICT 3 at Biharshariff	05.06.2021	17:10 hrs
400KV/220kV 500 MVA ICT 4 at Biharshariff	05.06.2021	17:10 hrs
220 kV Biharshariff-Fatwa D/C	05.06.2021	17:10 hrs
220 kV Biharshariff-Khizisarai D/C	05.06.2021	17:10 hrs
220kV-Tenughat- Biharshariff -1	05.06.2021	17:10 hrs
220 kV Bus-1 & 2 at Biharshariff (BSPTCL)	05.06.2021	17:10 hrs

Network across the affected area (प्रभावित क्षेत्र का नक्शा):

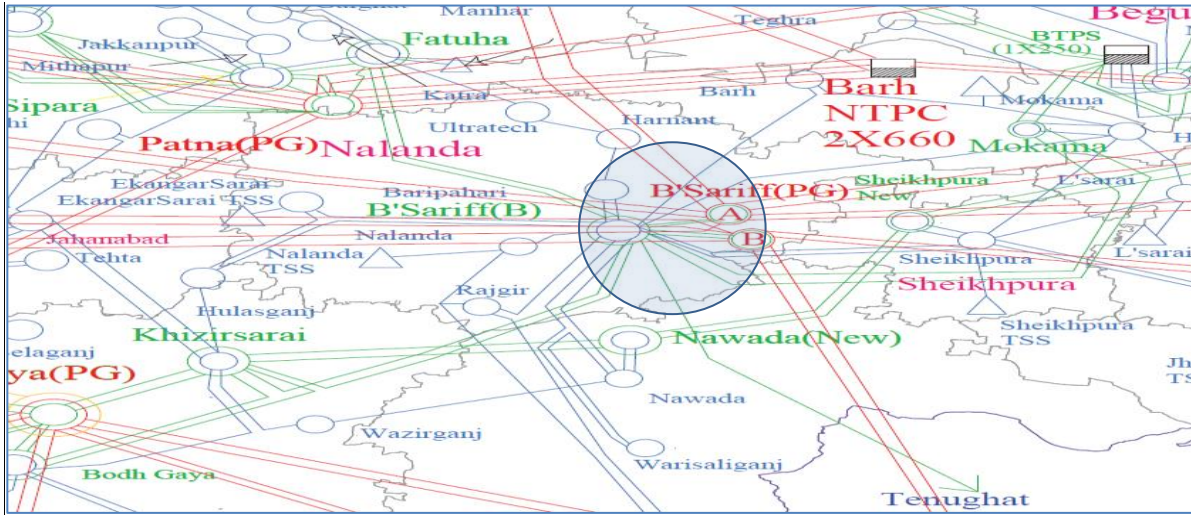

Figure 1: Network across the affected area

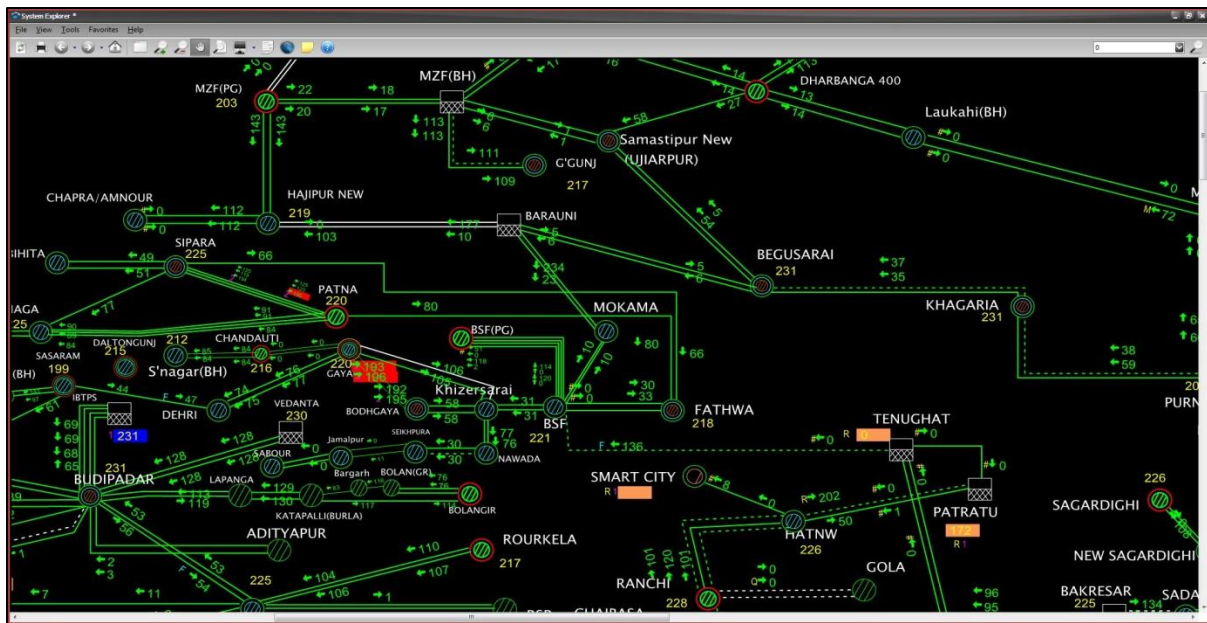

Figure 2: SCADA snapshot for of the system

Relay indication and PMU observation (रिले संकेत और पीएमयू पर्यवेक्षण):

समय	नाम	उप केंद्र 1 रिले संकेत	उप केंद्र 2 रिले संकेत	पीएमयू पर्यवेक्षण
17:10 Hrs.	400KV/220kv 315 MVA ICT 1 at Biharshariff	ICT tripped from LV side on Master trip relay.	NA	Initially R phase fault which got cleared within 100ms ,but after 200 ms same got converted to R-Y phase fault and got cleared in Zone-2 time from remote ends .
	400KV/220kv 315 MVA ICT 2 at Biharshariff	Inter-trip from HV side.	ICT tripped on differential protection from HV side.	
	400KV/220kv 315 MVA ICT 3 at Biharshariff	ICT tripped from LV side on Master trip relay.	NA	

400KV/220kv 500 MVA ICT 4 at Biharshariff	Tripped from LV side on LBB	NA	
220 kV Biharshariff-Fatwa D/C	Ckt-2 tripped from BSF on non-directional ,high set o/c Protection.	Ckt-1 tripped in zone -2 from Fatwa end.	
220 kV Biharshariff-Khizisarai D/C	Both ckt tripped from BSF on non-directional ,high set o/c Protection.		
220KV- Tenughat- Biharshariff -1		Z-2 , R phase FC- 1.096kA FD-177.5 km	

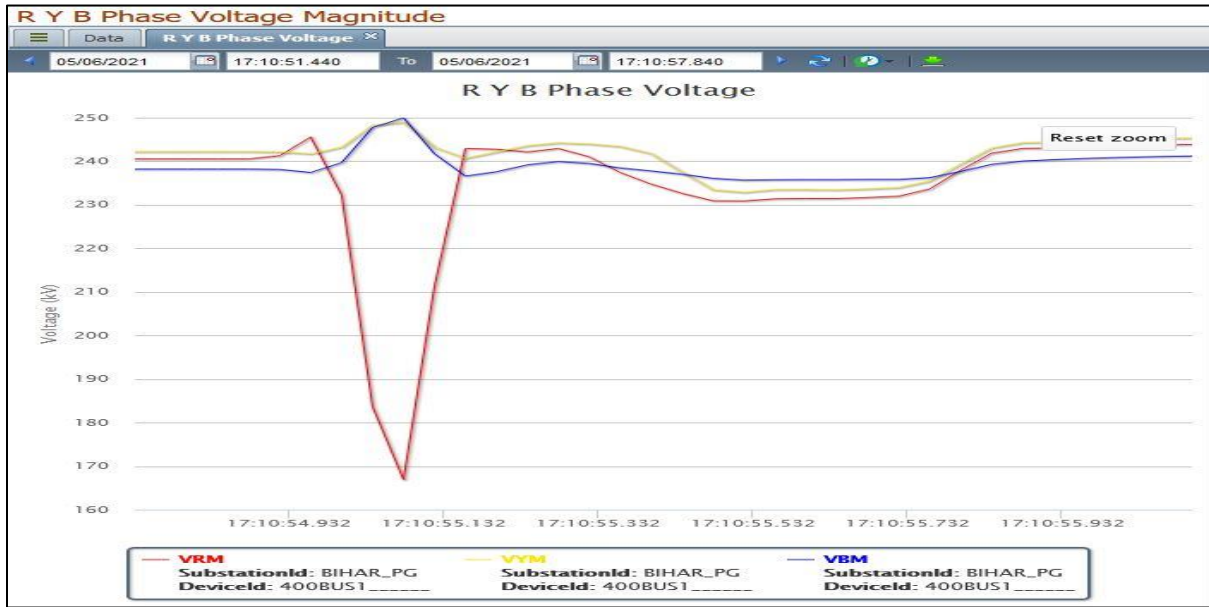

Figure 3: Three phase Bus voltage captured by Biharshariff PG PMU shows existence of R phase to earth fault then a R-Y phase.

Restoration (पूर्वावस्था की प्रप्ति)

Transmission Element	Restoration Date	Restoration time
400KV/220kv 315 MVA ICT 1 at Biharshariff	05.06.2021	18:12 hrs
400KV/220kv 315 MVA ICT 2 at Biharshariff	05.06.2021	21:07 hrs
400KV/220kv 315 MVA ICT 3 at Biharshariff	05.06.2021	17:52 hrs
400KV/220kv 500 MVA ICT 4 at Biharshariff	05.06.2021	21:28 hrs
220 kV Biharshariff-Fatwa D/C	05.06.2021	18:24 hrs
220 kV Biharshariff-Mokama D/C	05.06.2021	18:18 hrs
220 kV Biharshariff-Khizisarai D/C	05.06.2021	18:30 hrs
220kV-Tenughat- Biharshariff -1	05.06.2021	18:35 hrs
220 kV Bus-1 & 2 at Biharshariff (BSPTCL)	05.06.2021	17:52 hrs

Analysis of the event (घटना का विश्लेषण):

- All elements emanating from 220 kV Biharshariff, tripped due to R Phase CT blast at 220 kV side.
- From PMU and DR plot it is evident that initially there was R phase fault due to CT blast which got isolated within 100ms, but after 200ms same got converted to R-Y phase fault and got cleared after 500 ms.
- ICT -2 LV side CT blasted and differential protection operated from HV side clearing the same fault.
- While ICT-1&3 tripped from LV side on Master trip relay.
- As per preliminary information received ,ICT-4 tripped on LBB so for ICT 4. which relay gave tripping commands that breaker did not opened and LBB initiated needs to be checked. (BSPTCL to explain)
- 220 kV Biharshariff- Khizisarai D/C tripped from Biharshariff, due to operation of definite time Non -Directional High set protection enabled at Biharshariff end after delay of 500ms. It tripped sensing the second evolved fault which was R-Y in nature. Fault was in reverse direction to Biharshariff, For ckt-2, zone-4 also picked and gave trip command after 500 ms, timings of High set and Zone-4 are set same.
- Whether Biharshariff end picked zone-4 for all other lines emanating from Biharshariff also needs to be looked into.(BSPTCL to explain) . Time delay of Z-4 protection can be reduced for faster fault clearance until the Busbar is commissioned. Whether Khezesarai picked up the fault in zone-2 or not? (BGCL to explain).
- Similar is the case with 220 kV Biharshariff Fatwa -2 this line also tripped due to operation of definite time Non -Directional High set protection enabled at Biharshariff end after delay of 500ms. It tripped sensing the second evolved fault which was R-Y in nature. Fault was in reverse direction to Biharshariff . Whether Zone-4 ,picked for this line at BSF end?(BSPTCL to explain).
- 220 kV Biharshariff-Fatwa -1 tripped from Fatwa end on zone-2 after 350 ms, sensing the R-Y fault. Whether High set and Zone-4 ,picked for this line at BSF end?(BSPTCL to explain).
- 220 Biharshariff- Tenughat tripped from only Tenughat end on zone -2, Whether High set and Zone-4 ,picked for this line at BSF end?(BSPTCL to explain)
- Sequential tripping occurred some on zone-2 from remote end some from Local end on High set and Z-4 as time delay for all protections are close to each other and there was racing between them whoever wins cleared the fault first.
- It seems Ct blast created some Bus fault of R- Y nature which finally got cleared by tripping of lines in zone-2 from remote end and Non directional high set from local end and Z-4 of Local end. As no bus bar is available so if such equipment failures causes' bus faults it will be always delayed cleared endangering grid security and reliability.

Protection issues observed (सुरक्षा समस्या):

Issues requiring immediate action for rectification:

(1) Bus Bar Protection Scheme at 220 kV Bus of 220/132 kV Bihar Sharif Substation:

- a) At present Bus bar protection is not available at 220 kV bus at Bihar Sharif. In addition, 220 kV Bihar Sharif Fault level is also on the higher side and in absence of

bus bar protection during bus fault, any delayed clearance can also damage other major equipment.

- b) In view of the above, it is advised from ERLDC that bus bar protection commissioning may be given high priority and to be completed at the earliest.
- c) As observed frequent equipment failures and non-availability of bus bar such equipment failures causes bus faults it will be always delayed cleared from remote ends endangering grid security and reliability.

(2) Simultaneously tripping of Multiple ICTs :

- a) This issue is persisting since long where for the nearby faults ,ICTs were tripping simultaneously for close 400 Kv line faults ,these type of spurious trappings has been reduced to some extent after replacement of old cables an busbar panels by BSPTCL on 220 kV side.
- b) But tripping of all other remaining ICTs on fault in any one ICT (equipment failure associated with a anyone ICT) is observed again in last two events.
- c) Rest Healthy ICTs are tripping from LV side on Master trip relay .What is causing initiation or signal extension to master trip needs to be identified as soon as possible.
- d) PCC recommended following actions to be completed as early as possible, (response awaited)
 - To carry out detail checking of the cables/wirings between HV and LV side of the 400/220 kV ICTs at Biharshariff S/s. Also to check substation DC healthiness on 220 kV side.
 - To configure the disturbance recorder of the relays for LV side of the ICTs so that DRs can be available during tripping of the ICTs for analysis.
 - To submit the status of bus bar protection for 220 kV bus of Biharshariff S/s.

(3) Vulnerability of Distance Relays:

- a. It has been observed that Distance relays are not sensing the faults as required. Zone-4 of local end and Zone-2 of remote ends are all needed to be checked and co-ordinated so that in case of such faults they can ensure correct operation and faster clearance of faults.

(4) Frequent Failure of LV side R phase CT of ICT-2:

- a) Root cause analysis for R Phase CT failure of ICT-2 needs to be done ,as in the month of April it was replaced and again same equipment has blasted . CT make and year needs to be intimated.
- b) Proper maintenance, DGA analysis needs to be done to identify problem beforehand.
- c) Whether CT secondary accidentally became open? OR secondary CT burden got disconnected.

- d) Whether Oil level was above marking level. All these practices needs to be adopted and needs to be considered for root cause analysis. Root cause analysis done for CT failure of 03 April tripping may be shared.

Non-compliance observed (विनियमन का गैर-अनुपालन):

Issues	Regulation Non-Compliance	Utility
DR/EL not provided within 24 Hours	1. IEGC 5.2 (r) 2. CEA grid Standard 15.3	BSPTCL/POWERGRID-ER1
Fault clearance in more than 100 ms at 400 kV level and above and 160 ms at 220 kV levels	1. CEA Grid standard 2010 -3.e CEA Transmission Planning Criteria	BSPTCL
Incorrect/ mis-operation / unwanted operation of Protection system	1. CEA Technical Standard for Construction of Electrical Plants and Electric Lines: 43.4 .A. 2. CEA (Technical standards for connectivity to the Grid) Regulation, 2007: Schedule Part 1. (6.1, 6.2, 6.3)	BSPTCL

Status of Reporting (रिपोर्टिंग की स्थिति):

- DR/EL for ICTs not yet received from BSPTCL/PG-ER-1/TTPS.
- Detailed report yet to be received from BSPTCL.

Annexure 1: Sequence of events recorded at ERLDC SCADA data at the time of the event.

No SCADA captured for Biharshariff S/S for 05/06/2021

Annexure 2: DR recorded at Biharshariff end for 220 kV Biharshariff-Khezesarai I:

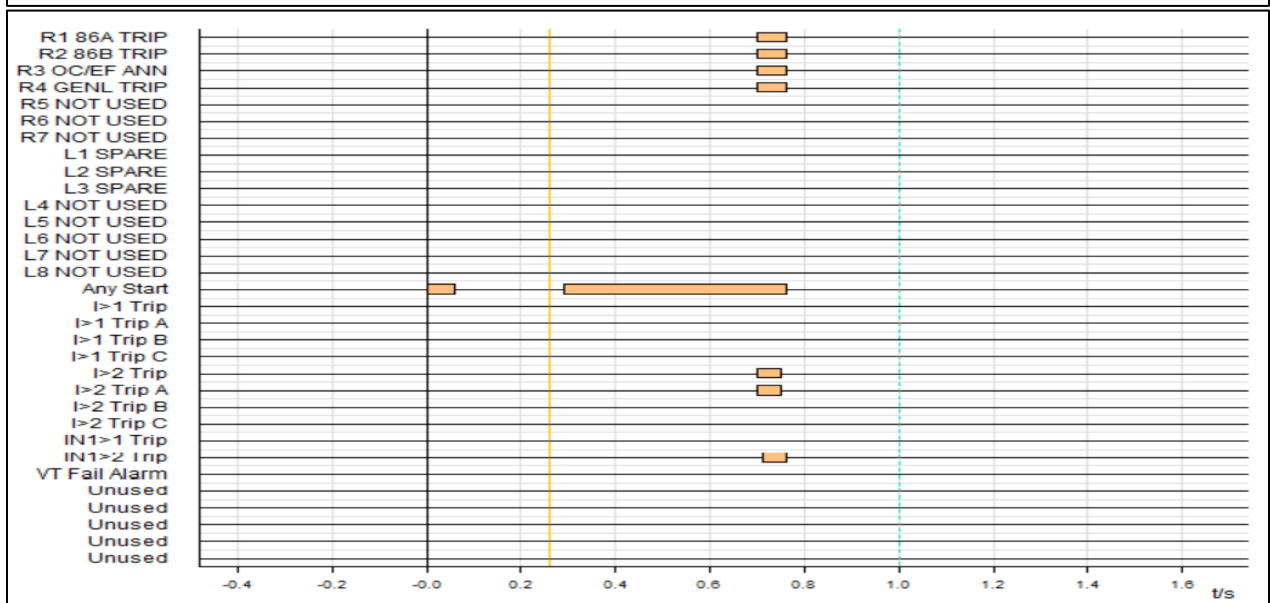
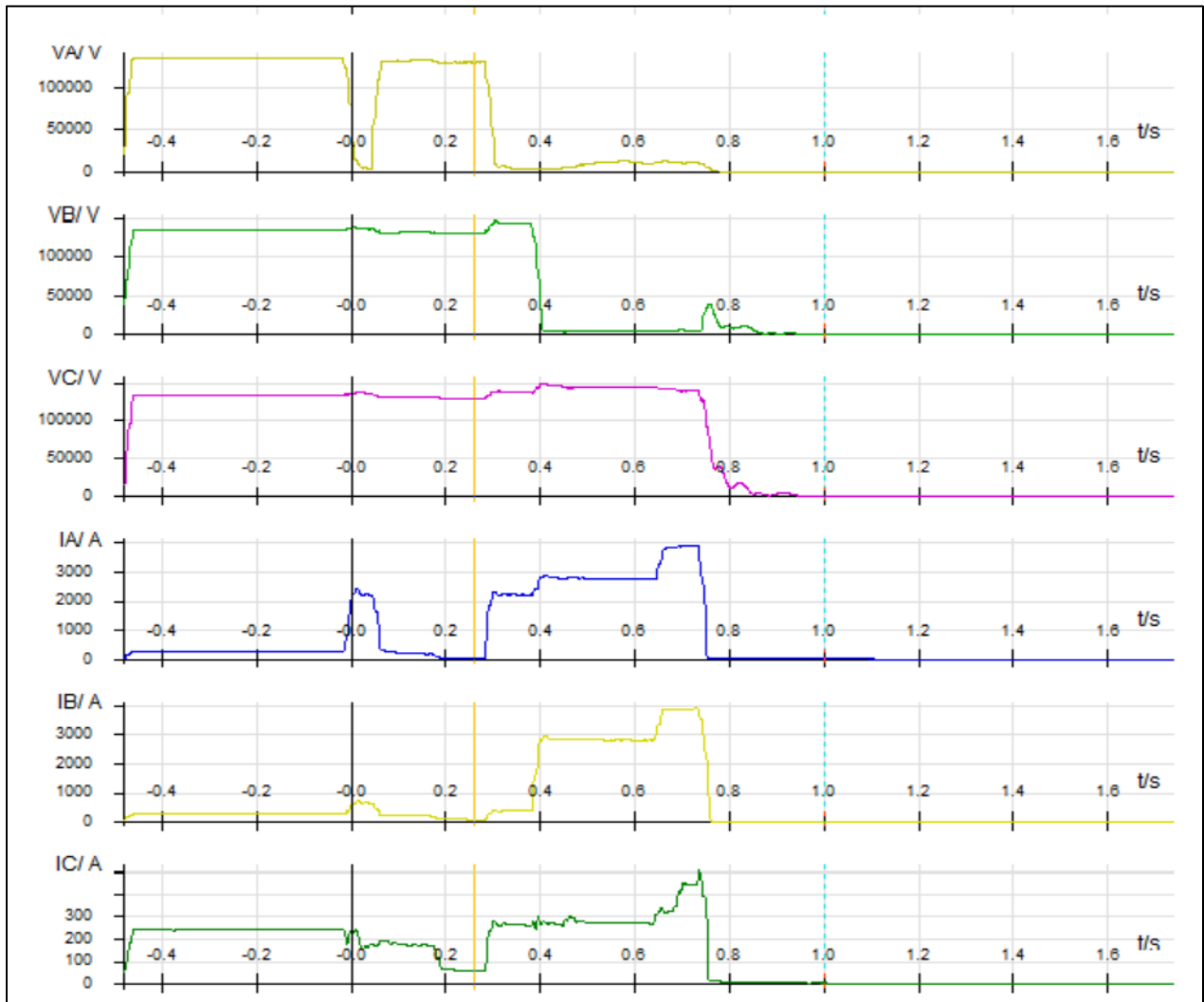

DR recorded at Biharshariff end for 220 kV Biharshariff-Khezesarai II

DR(Distance relay)

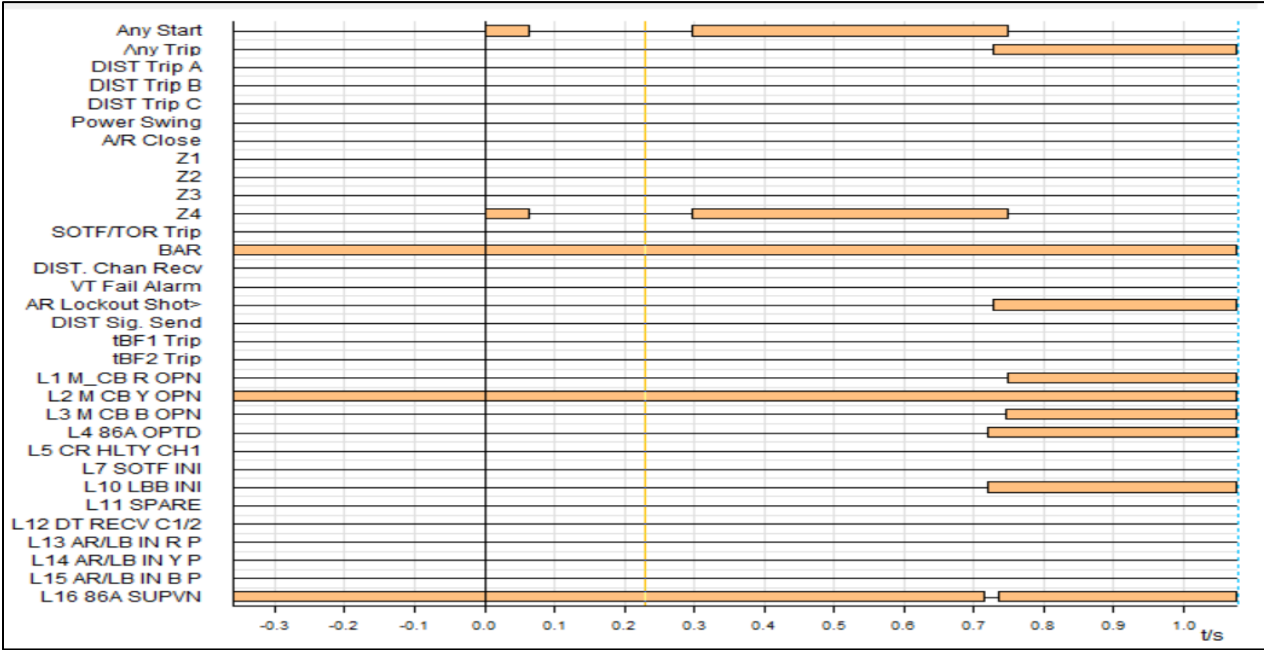
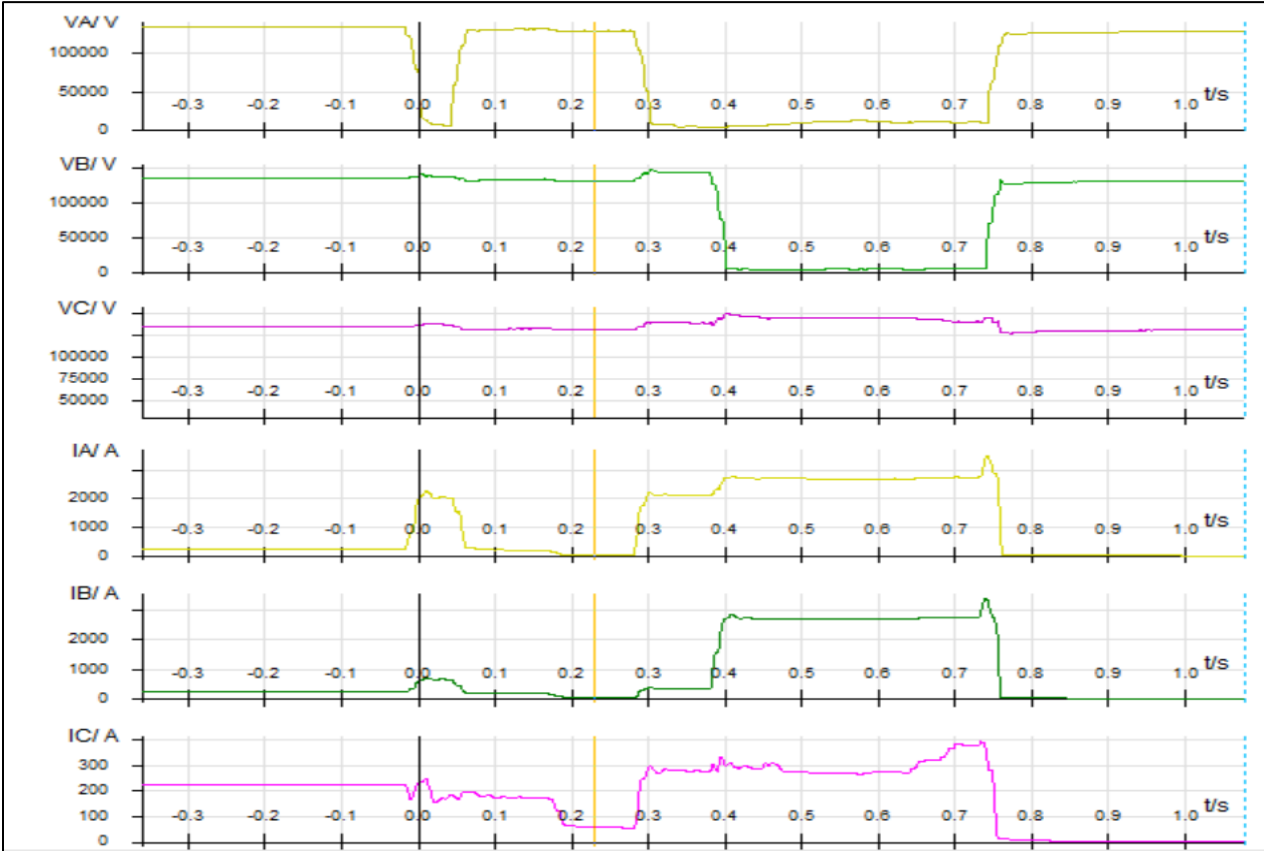

DR recorded at Fatwa end for 220 kV Biharshariff-Fatwa I:

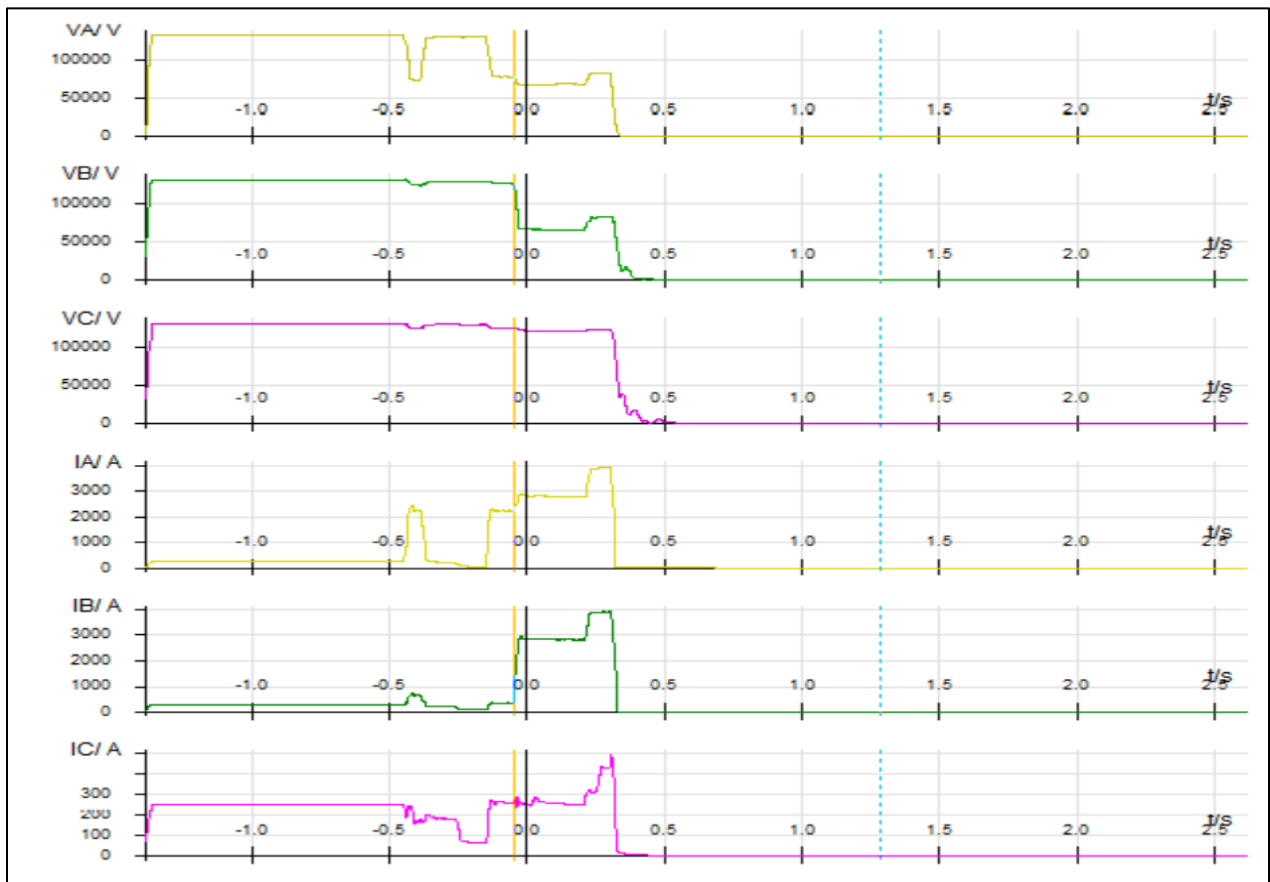

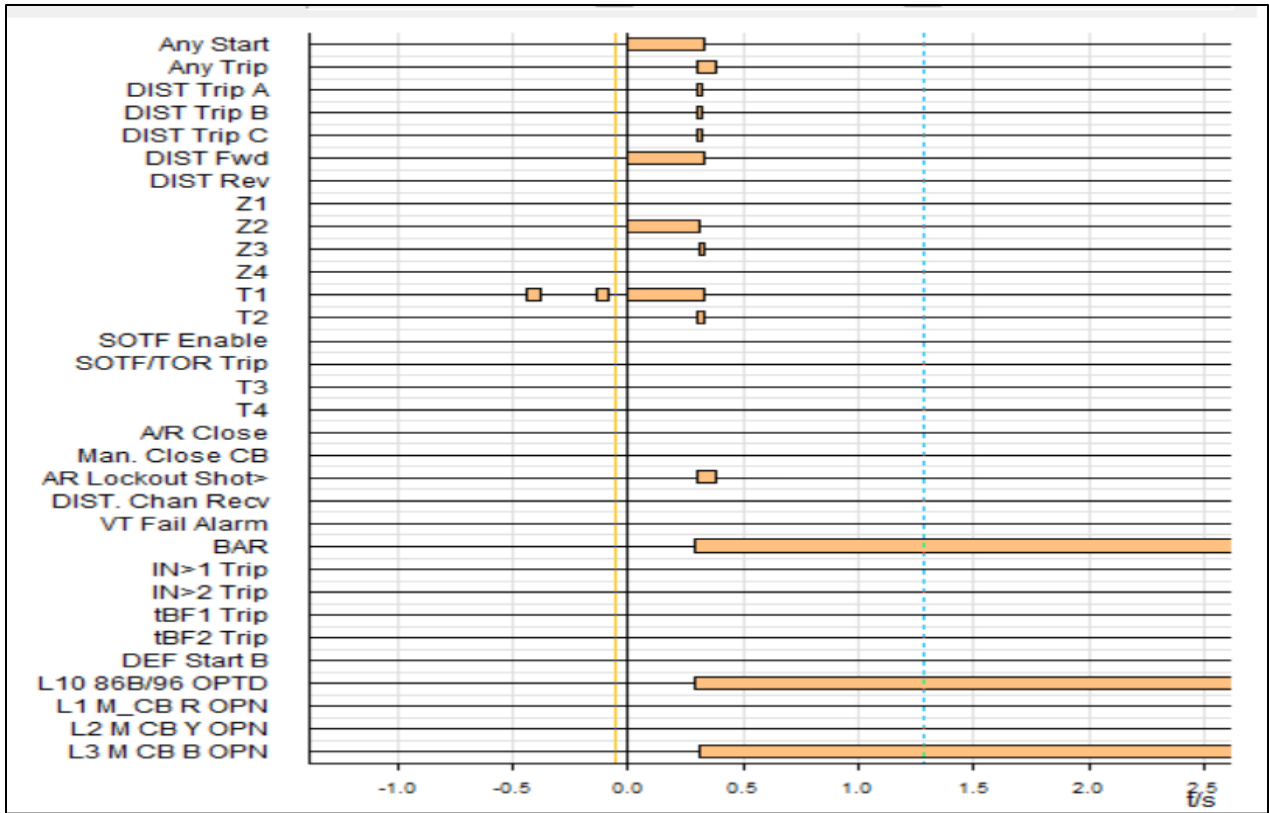

DR recorded at Bsf end for 220 kV Biharshariff-Fatwa II:

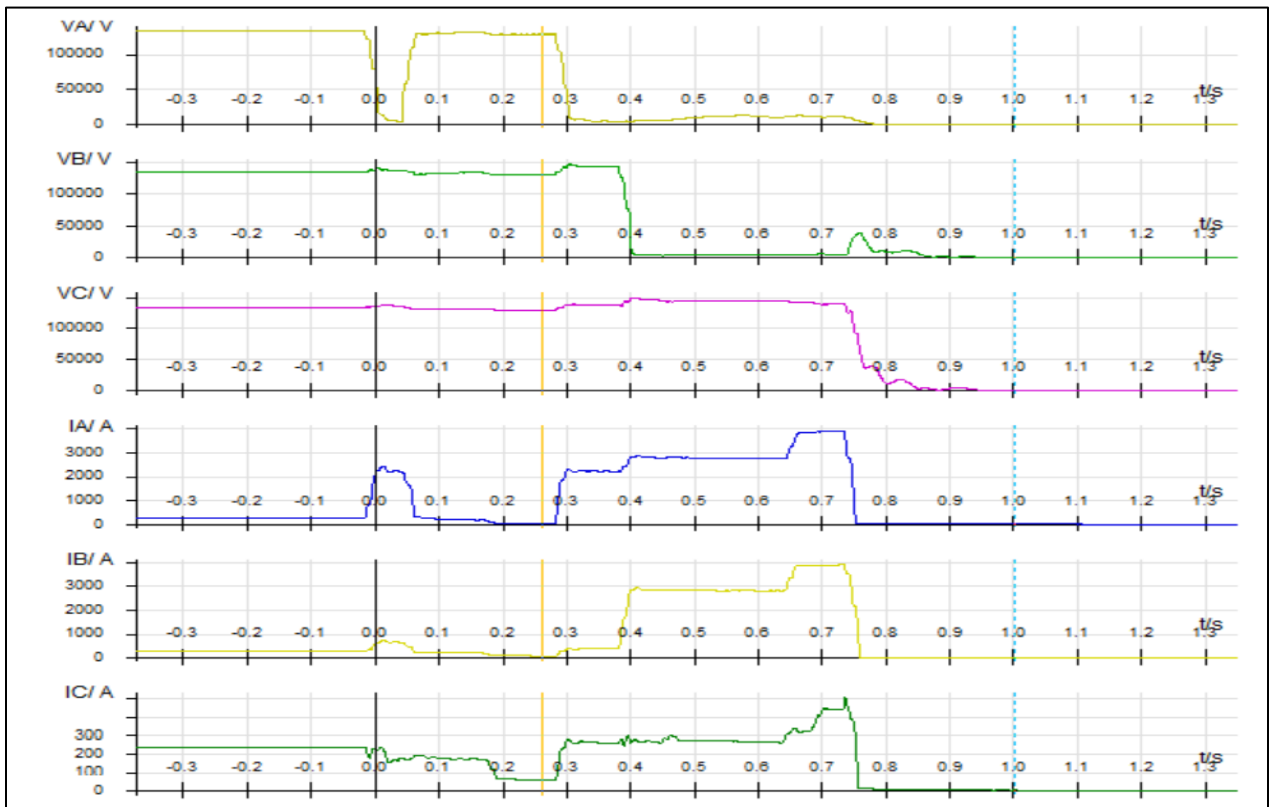

Tripping DETAILS

FOR PCC MEETING

Disturbance of 220kv Biharsariff on dated 05.06.21 at 17:10 hrs

1. Bus bar protection scheme at 220kv bus of 220/132kv Biharsariff:-

- Email has been sent on 25.06.21 to the concerned GM for early commissioning of bus bar protection scheme.

2. Simultaneously tripping of multiple ICTs:-

- (a) Tan delta test of CTs installed at LV of ICT 1 has been performed. Results was satisfactory except R-ph CT. An email has been sent for early R-ph CT replacement of the CT.
- (b) CT secondary injection test of R,Y,B-ph ICT 1&2 yielded result within limit.
- (c) Y-ph breaker mechanism box of ICT 1 found defective and has been replace.
- (d) Breaker timer test of R,Y,B-ph breaker done .Results found satisfactory.
- (e) For details checking of the cables/wiring b/w HV and LV side of 400/220kv ICT ,shutdown has been granted for 14.07.21 &15.07.21.For ICT 1&ICT 2 respectively.
- (f) Out of two DC sources, one is balanced, for another source Work for improving DC health in is being done.

TRIPPING DETAILS:-

3. Vulnerability of distance relays:-

- ICT 2 LV R-ph breaker might not have opened in time limit because of which fault processed to bus. That why zone 2 occurred at remote end. Zone 4 at local end did not operate in case of BSF-Khizirsarai DC and BSF- Fatuha ckt 2 because delay for highset of O/C ,E/F relay is 400ms and delay for zone 4 trip is 500ms ,tripping occurred on highset.

4. Frequent failure of LV side R-ph CT of ICT-2:-

- Its healthiness is being monitored now on regular basis.

पावर सिस्टम ऑपरेशन करपोरेशन लिमिटेड

(भारत सरकार का उद्यम)

POWER SYSTEM OPERATION CORPORATION LIMITED

(A Government of India Enterprise)



Eastern Regional Load Despatch Centre: 14, Golf Club Road, Tollygunge, Kolkata-700 033.

CIN: U40105DL2009GOI188682

फ़ोन: 033- 24235755, 24174049 फ़ैक्स : 033-24235809/5029 Website: www.erldc.org, Email ID- erldc@posoco.in

घटना संख्या: 25-06-2021/1

दिनांक: 30-06-2021

Report on the grid event in Eastern Region (पूर्वी क्षेत्र में ग्रिड घटना पर रिपोर्ट)

Summary of the event (घटना का सारांश):

220 kV Tashiding substation is having only two interconnections, 220 kV Tashiding-New Melli S/C and 220 kV Tashiding -Rangpo S/C. 220 kV Tashiding-Rangpo S/C and 220 kV Tashiding-New Melli S/C tripped at 04:54 hrs on Y-B fault. At the same time, Tashiding unit -1 and unit-2 tripped due to loss of evacuation path resulting in total power failure at Tashiding HEP.

- **Date / Time of disturbance:** 25-06-2021 at 04:54 hrs.
- **Event type:** GD - 1
- **Systems/ Subsystems affected:** 220 kV Tashiding Hydroelectric Plant.
- **Load and Generation loss.**
 - 90 MW generation loss at Tashiding HEP.
 - No load loss was reported during the event.

Major elements tripped (प्रमुख ट्रिपिंग):

- 220 kV Tashiding-Rangpo S/C.
- 220 kV Tashiding-New Melli S/C.

Network across the affected area (प्रभावित क्षेत्र का नक्शा)

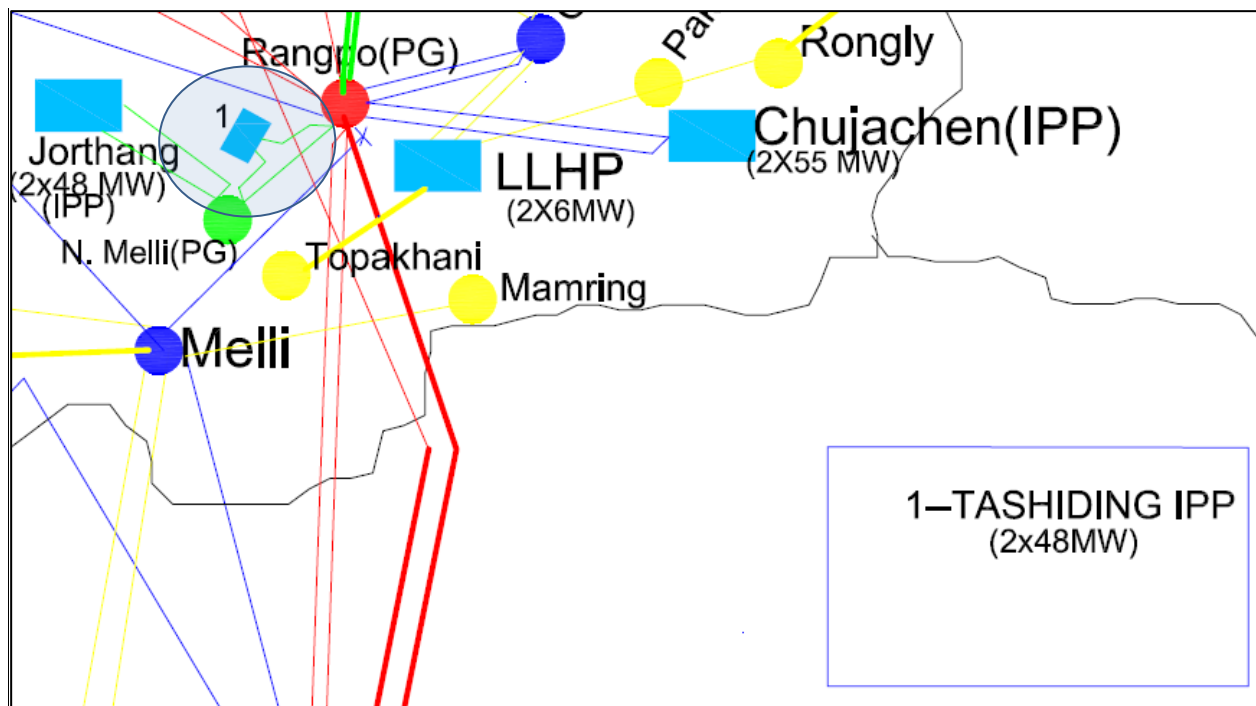

Figure 1: Network across the affected area



Figure 2: SCADA snapshot for of the system

Relay indication and PMU observation (रिले संकेत और पीएमयू पर्यवेक्षण):

समय	नाम	उप केंद्र 1 रिले संकेत	उप केंद्र 2 रिले संकेत	पीएमयू पर्यवेक्षण
04:54 Hrs.	220 kV Tashiding-Rangpo S/C	Y-B Earth, Iy=1.19kA, Ib=5.46kA, 7.53 Km	Y-B Earth, Iy=5.4kA, Ib=5.2kA, 44.42Km.	Around 30kV dip is observed in PMU. Two consecutive dips in Y-B phase voltage are captured. Fault clearing time was around 240 ms.
	220 kV Tashiding-New Melli S/C	Y-B Earth, Iy=1.22kA, Ib=5.52kA, F/D-5.86KM	Y-B Earth Iy=4.67 kA, Ib=5.15kA at 10 km.	

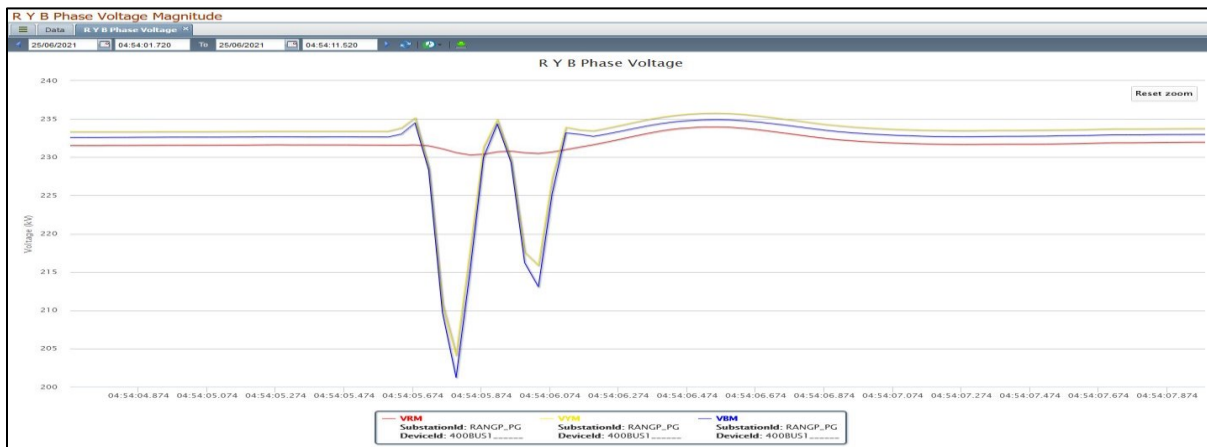

Figure 3: Three phase voltage captured by Rangpo PMU shows existence of Y-B fault at 04:54 hrs. Around 30 kV dip has been observed in Y phase and 35 kV dip is observed in B phase voltage at Rangpo PMU. Two consecutive dips in Y-B phase are captured. Fault clearing time was around 240 ms.

Restoration (पूर्वावस्था की प्रप्ति)

- 220 kV Tashiding-Rangpo S/C was restored at 17:49 hrs on next day i.e. 26-06-2021.

Analysis of the event (घटना का विश्लेषण):

SLD of Affected Area:

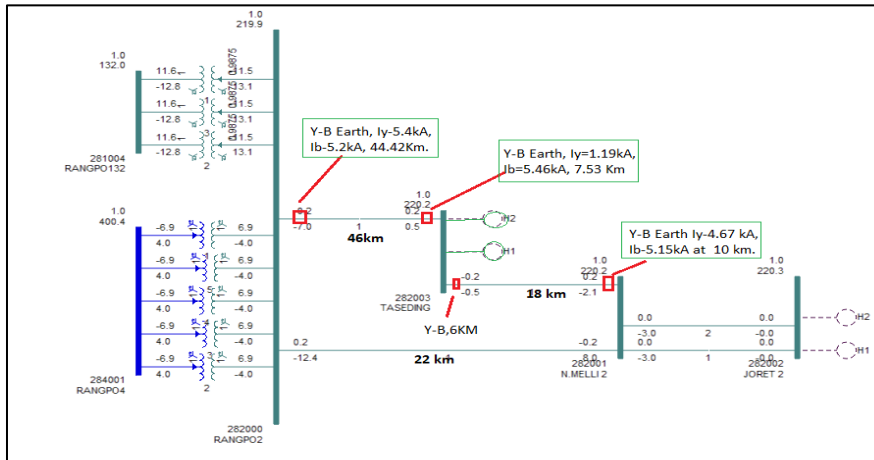

ANALYSIS:

- From DR plot it is clear that first fault was encountered by 220 Kv Tashiding-New Melli line. At New Melli end fault was sensed in zone -1 with Y-B nature at a distance of 10 km, and 3 phase tripping occurred .
- While at Tashiding end for New melli -Tashiding line also same fault was sensed in zone-1 at a distance of 6km from Tashiding end . Line tripping occurred from both end by 04:54:05:812 . Fault was initially in Y phase converted to Y-B phase fault .
- From DR of 220 kV Tashiding-Melli of Tashiding end it is seen that the Fault was slowly building and leakage is started prior to the final flash over in the Y phase. And When B-Phase voltage is at the peak, flash over took place between Y-phase of Melli and B-Phase of Rangpo line.
- From DR of 220 kV Tashiding-Rangpo of Tashiding end it is seen that the Fault was slowly building and leakage is started prior to the final flash over. Then 1st fault took place at the same instant of 220 kV Tashiding-melli. Then after another 100 ms another Y-B phase fault took place.
- Same fault was initially also sensed by Rangpo end and Tashding end in zone-2 and Zone-4 respectively for (Rangpo -Tashding line) indicating that fault first occurred in Tashding-New melli line ,but as soon the Tashding-New melli tripped from both end fault got cleared .
- After 100 ms, same fault of Tashding-New melli created the fault in Rangpo-Tashding line with same Y-B phase fault which was sensed in zone-1 this time from both ends and line tripped from both ends by 04:54:06:041 . Fault distance From TASHDING end was 7.2 Km.
- As appeared from DR signature it shows fault in the common portion of the above mentioned two lines, as in both lines fault distance is also same approximately from Tashding end (6-7Km). It shows fault of one line created fault on other line showing suspected, conductor snapping creating fault in other line.
- Fault was of evolving nature B phase converting to Y-B phase and at the second instance of fault when Rangpo Tashding tripped ,very high voltage in Y&B phase was observed indicating fault due to suspected insulator back-flashover.

DR of Rangpo & Tashiding end for Rangpo-Tashiding Line:

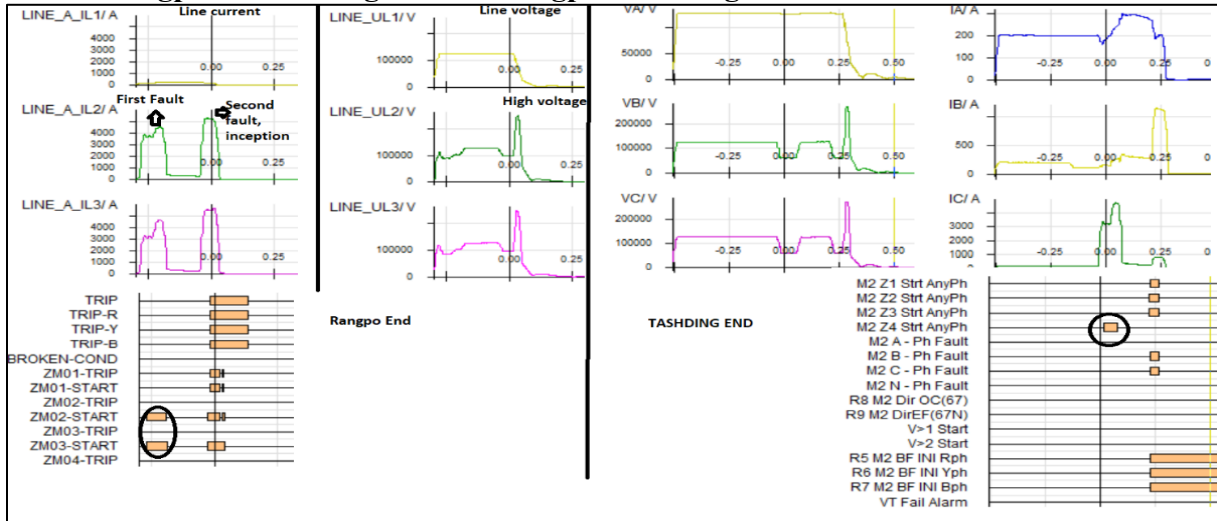

Later information from Tashiding received which were validating the outcomes of DR analysis .

As per Tashiding following information received which are validating all above observations:

ROOT CAUSE ANALYSIS:

- When Patrolling of line was done it was found that at THEP's Tower no. 22; Y-Phase conductor of both the lines were detached from the tower and Tashiding - Rangpo line Y-B phase conductors were entangled with each other.
- After further analysis it was found that Tashiding-New Melli TL's Y-Ph composite insulator string was broken into two parts from near to lower end of the string.
- Since both the lines were turned almost at 90 degree to connect with ENPD's Tower No. AP1; THEP - Rangpo Line naturally crosses THEP - New Melli line.
- Moreover THEP-Rangpo line phases were supported with the help of composite insulators from the respective phases of THEP-New melli line to maintain clearances(This arrangement is applicable in Interim arrangement of lines).
- Due to this when Y-Ph of THEP - New Melli line detached from the tower, it also pulled the Y-Ph of THEP-Rangpo line and consequent to this, its conductor also detached from the THEP tower arm and after detachment of tower arm Y-Ph conductor fell over the B-Ph of same line and entangled with the B-phase conductor.

Interim arrangement through which THEP-Rangpo line phases were supported with the help of composite insulators from the respective phases of THEP-New Melli line



Issues Identified:

At location 22 the 220 kV Tashiding-Rangpo line crossed the 220 kV Tashiding-Melli as show above in Figure. However, as the conductor configuration is Vertical and Rangpo line and Melli line are crossing at an angle. Following factors may be critical therefore:

- Separation between R-Phase of Rangpo line and Y-Phase of Melli line might not be sufficient. Same goes for Y-Phase of Rangpo line and B-Phase of Melli.
- Further due to perpendicular crossing any lateral movement of one set of conductors due to wind flow in a particular direction may cause even lesser clearance between cross phases of the two lines.
- In Sikkim in the month of June, July and August the temperature remains highest therefore the Sag of the conductor increases and the clearance between cross phases of the two lines are further reduced. During the last year also two similar nature faults took place with similar fault distance and fault signature during the month of June. **Clearance between the phases needs to be checked under different sag conditions and temperature due to such arrangement.**
- Due to Phase-to-Phase high fault current very high mechanical stress is built on the Insulator string end-fitting hardware. This might have caused the failure of the end-fitting and conductor snapped for Tashiding-Melli line, which caused the second fault on the Rangpo line as the both line are hinged. **Hinging is creating extra tension load on the Melli line insulator. Proper analysis should be done on the mechanical loading under different fault and other conditions.**
- Area is also prone to lightning and high resistive zone so prone to insulator back-flashover which will result in damaging insulator and causing, permanent nature of fault in both lines.
- **Such interim arrangement caused double circuit permanent line fault and resulting to delay in restoration.**

Non-compliance observed (विनियमन का गैर-अनुपालन):

Issues	Regulation Non-Compliance	Utility
DR/EL not provided within 24 Hours	1. IEGC 5.2 (r) 2. CEA grid Standard 15.3	PG-ER-2
Fault clearance in more than 100 ms at 400 kV level and above and 160 ms at 220 kV levels	1. CEA Grid standard 2010 -3.e CEA Transmission Planning Criteria	PG-ER-2 THEP
Incorrect/ mis-operation / unwanted operation of Protection system	1. CEA Technical Standard for Construction of Electrical Plants and Electric Lines: 43.4 .A. 2. CEA (Technical standards for connectivity to the Grid) Regulation, 2007: Schedule Part 1. (6.1, 6.2, 6.3)	THEP

Annexure 1: Sequence of events recorded at ERLDC SCADA data at the time of the event.

- No Sequence of events reported at Tashiding S/S
- Sequence of events recorded at Rangpo and New Melli S/S

Rangpo				
TIME	MILLI_SEC	STATION	DESCRIPTION	STATUS
04:54:06	62	RANGP_PG	220_MELNW_PG_1_CB	Open
05:39:33	156	RANGP_PG	220_MELNW_PG_1_CB	Closed
05:39:33	241	RANGP_PG	220_MELNW_PG_1_CB	Open
New Melli				
04:54:05	809	MELNW_PG	220_RANGP_PG_2_CB	Open
05:45:30	64	MELNW_PG	220_RANGP_PG_2_CB	Open
05:45:30	64	MELNW_PG	220_RANGP_PG_2_CB	Open
10:10:09	80	MELNW_PG	220_RANGP_PG_2_L_ISO	Travel
10:10:12	37	MELNW_PG	220_RANGP_PG_2_L_ISO	Open
10:10:12	37	MELNW_PG	220_RANGP_PG_2_L_ISO	Open
10:10:12	37	MELNW_PG	220_RANGP_PG_2_L_ISO	Open
15:42:46	296	MELNW_PG	220_RANGP_PG_2_MB2_ISO	Closed

Annexure 2: DR recorded at Tashiding end for 220 kV Tashiding New-Melli S/C.

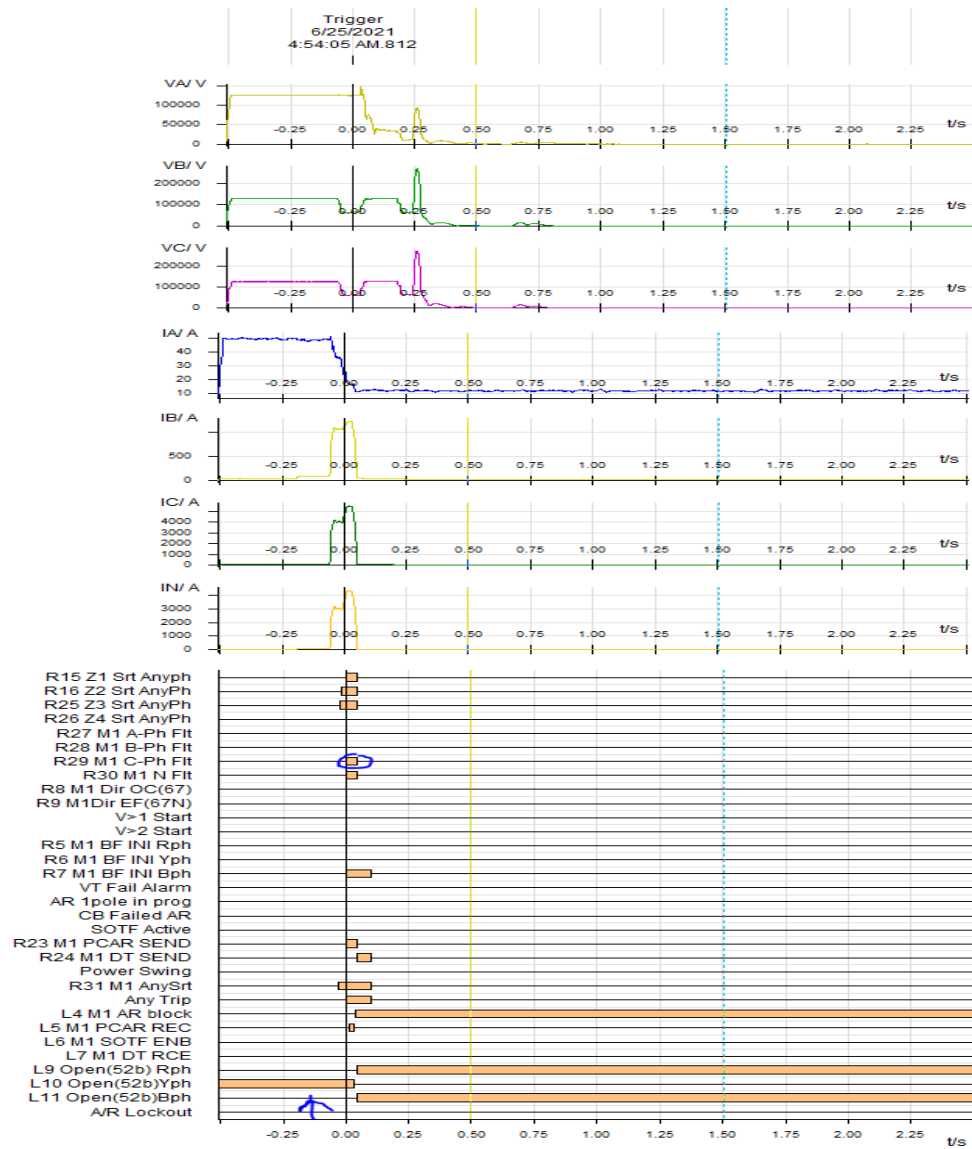

DR recorded at New Melli end for 220 kV Tashiding New-Melli S/C.

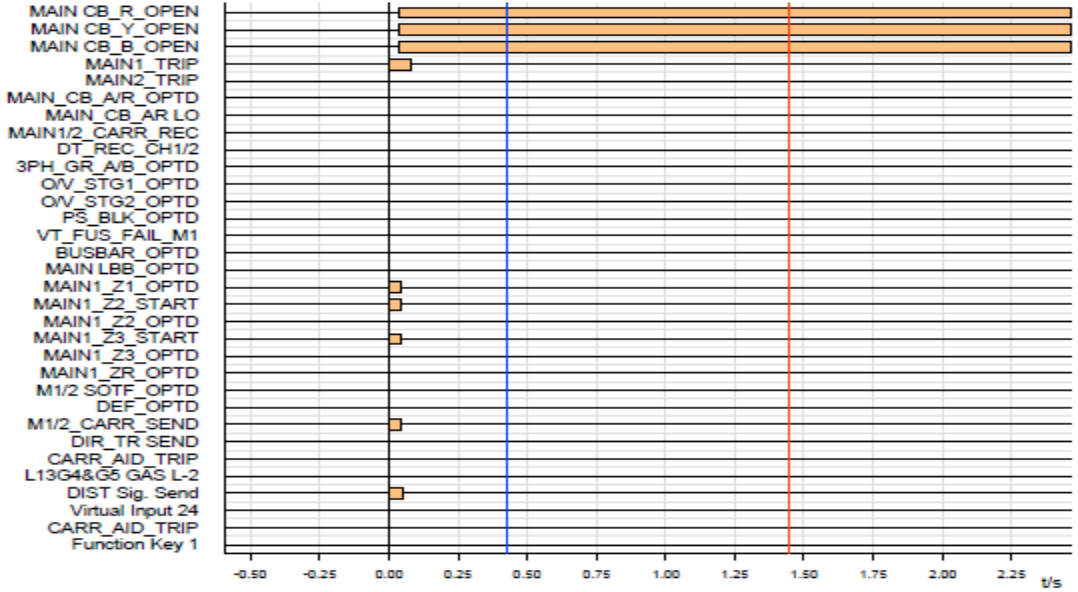
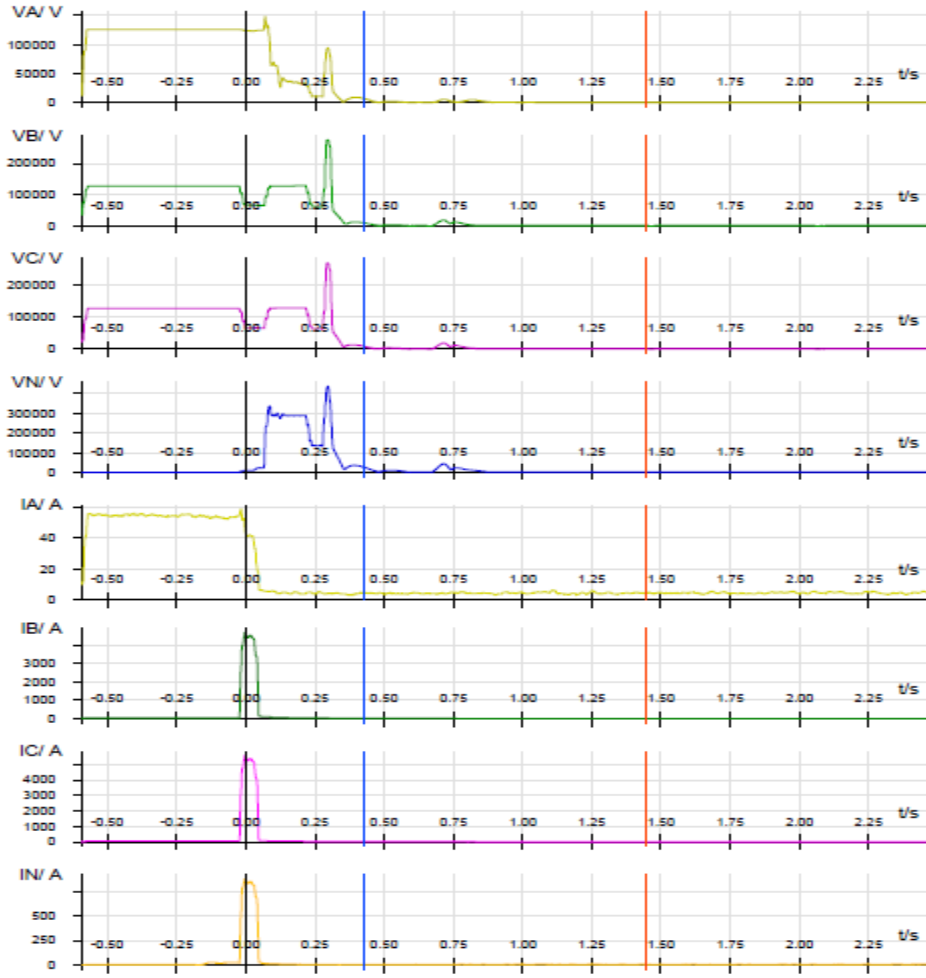

Annexure 2: DR recorded at Tashiding end for 220 kV Tashiding Rangpo S/C.

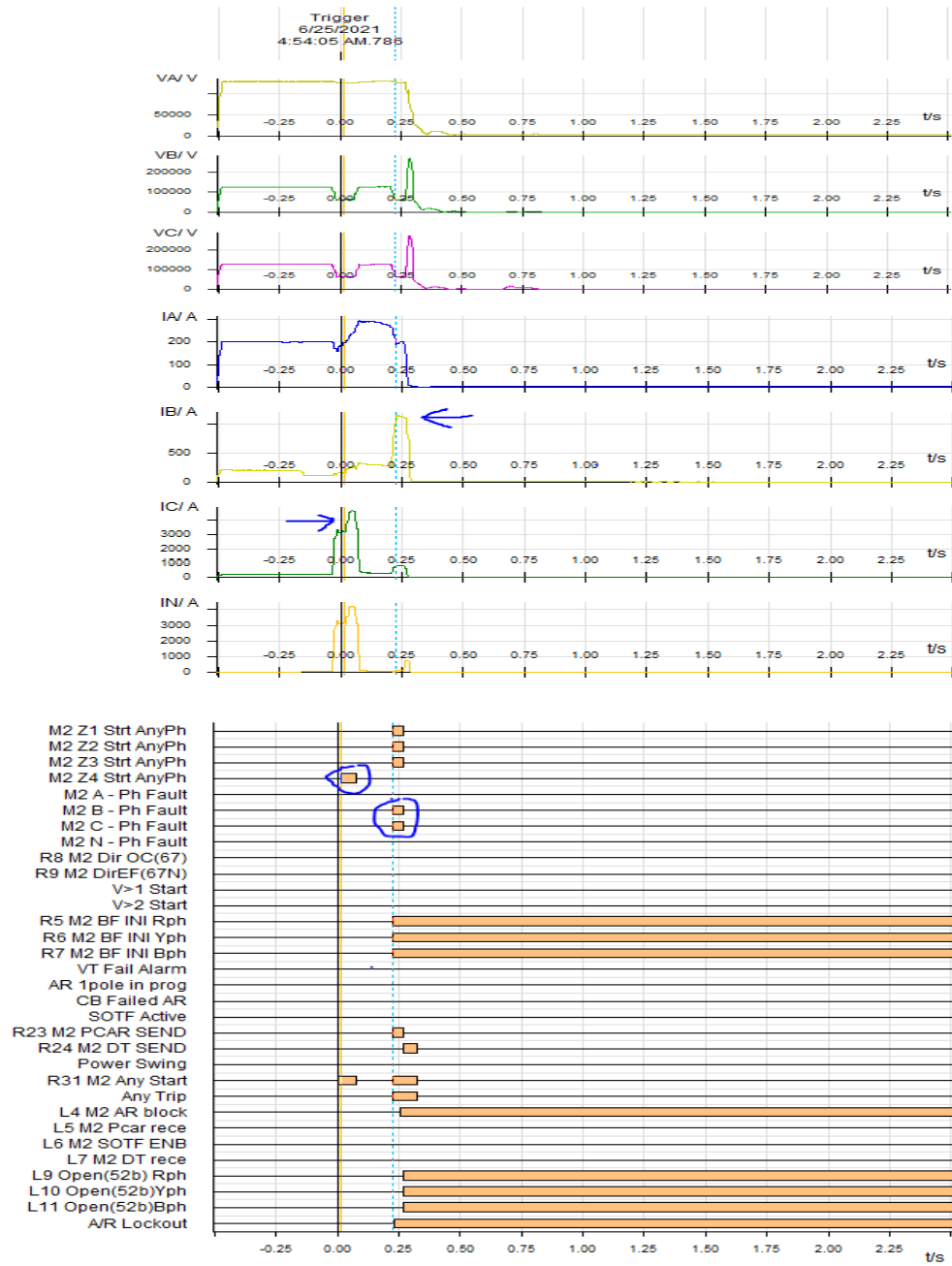

- Initially Fault sensed in Z-4 and after 250 ms. fault appeared in Y phase.

DR recorded at Rangpo end for 220 kV Tashiding Rangpo S/C.

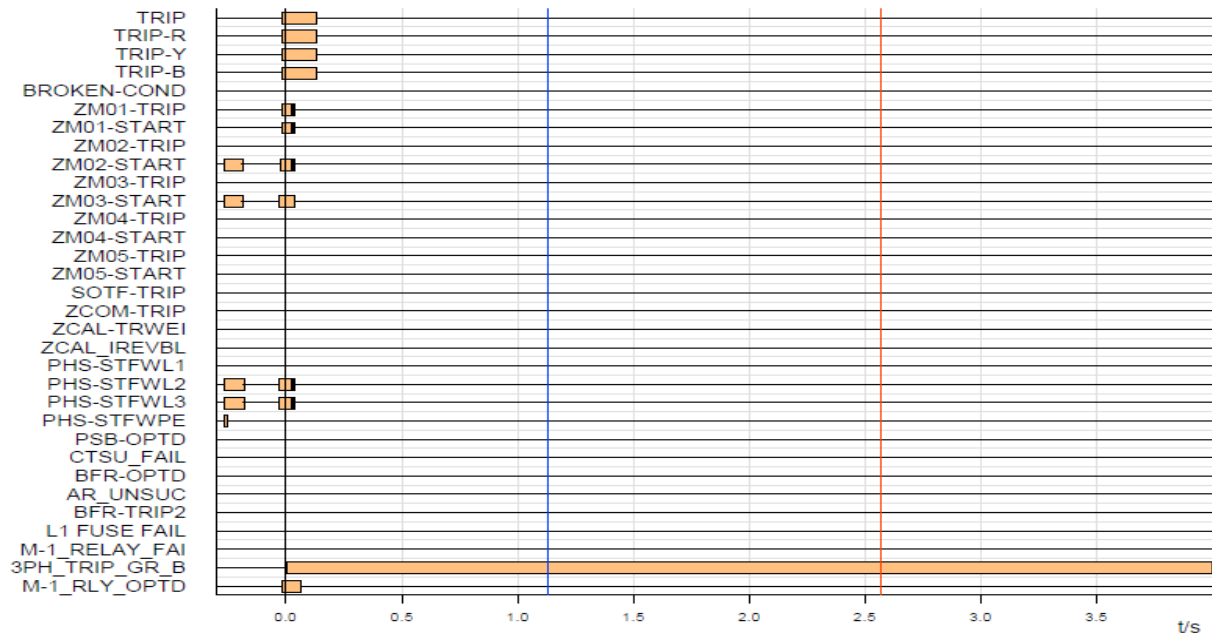
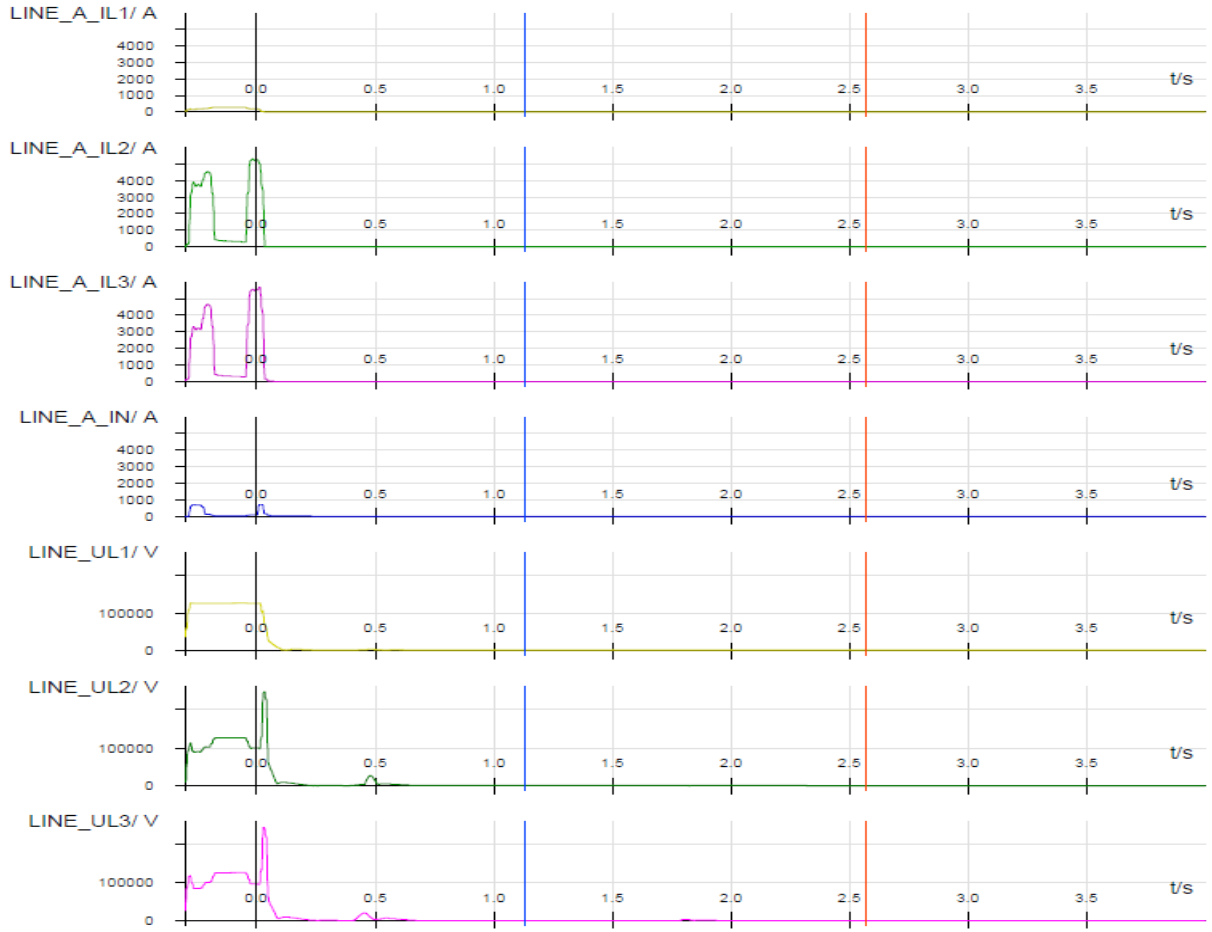

TRIPPING OF BOKARO -KODERMA

400 kV Bokaro -Koderma tripped 5 times in the month of June. Most of the faults were involving Y phase and 3 times with same location. Details are attached below along with remarks.

It may be appreciated that frequent tripping of transmission lines increases the possibility of power interruption and also endangering healthiness of connected generator (Bokaro)& (Koderma).

Hence you are requested to ensure healthiness of these, so that occurrence of faults is minimized.

Also as per the DR signature analysis it was observed that mostly fault is due to lightning, and location also found same in 3 events hence Tower footing resistance, Sheilding/ground wire near the location may be checked to ensure.

Sr No	Element Name	Tripping Date	Tripping Time	Reason	Remarks
1	400KV-KODERMA-BOKARO-1	21-06-2021	17:20	Koderma -Earth Fault,Y-ph,FD-100km, FC-3.08 kA	Fault location same as of 13/06. Tower footing resistance. Shielding may be checked. DR not received.
2	400KV-KODERMA-BOKARO-2	13-06-2021	15:37	KODERMA: Y-B-N , Fd= 71.2 kA, Iy= 5.57 kA, Ib= 4.5 kA	DR signatures shows a lightning fault nature first to Y and then B indicating backflover.Tower footing resistance .Sheilding/ground wire near the location may be checked.
3	400KV-KODERMA-BOKARO-1	13-06-2021	15:37	Koderma: Y-B-N, Fd= 101.9 km, Ib= 4.29 kA, Iy= 3.28 kA	
4	400KV-KODERMA-BOKARO-1	04-06-2021	13:56	KODERMA- Y-N fault,Zone 1,FD -50.5 km, FC -5.5 kA. BOKARO - A/R SUCCESSFUL.	DR signatures shows a lightning fault nature.
5	400KV-KODERMA-BOKARO-2	01-06-2021	14:07	Koderma :B-phase ,E/F (Ic=1.35 kA)	DR not received.

DR Analysis:

DR of Bokaro End for 04/06/2021:As can be seen lightning event can hit at any moment of voltage point and here it is observed that at zero crossing it hit the Y phase and due to which high DC offset in current observed also.

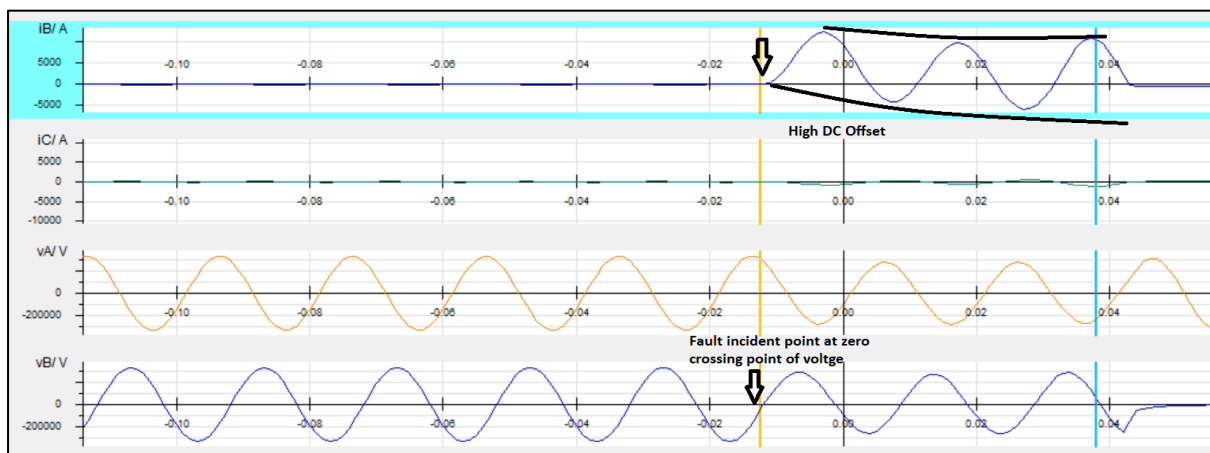

DR of Koderma End for 13/06/2021 For Ckt-2:

- In this case also Y-B phase fault observed, fault incident point was as shown in figure which is random point each time due to lightning hit.
- Also initially B phase fault observed then within 10 ms got converted to Y-B-G fault due to suspected Back flashover induced by lightning hit on B phase .

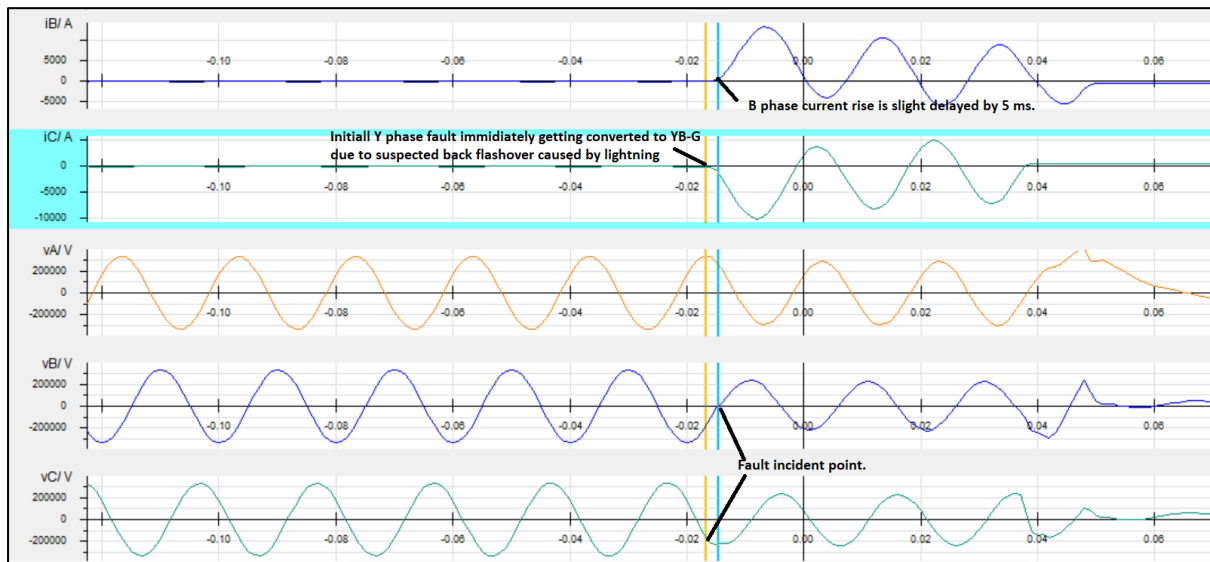

- It is not necessary that in lightning hit to phase conductors directly then only fault will occur if it hits to ground wire also and lightning current travels in both directions along the ground wire, it induces traveling waves in the phase conductors. When a traveling wave reaches the ground through a high inductance tower and the footing resistance is high, a flashover may occur.

DR of Bokaro End for 13/06/2021 For Ckt-1: In this case also Y-B phase fault observed, fault incident point was as shown in figure which is random point each time due to lightning hit.

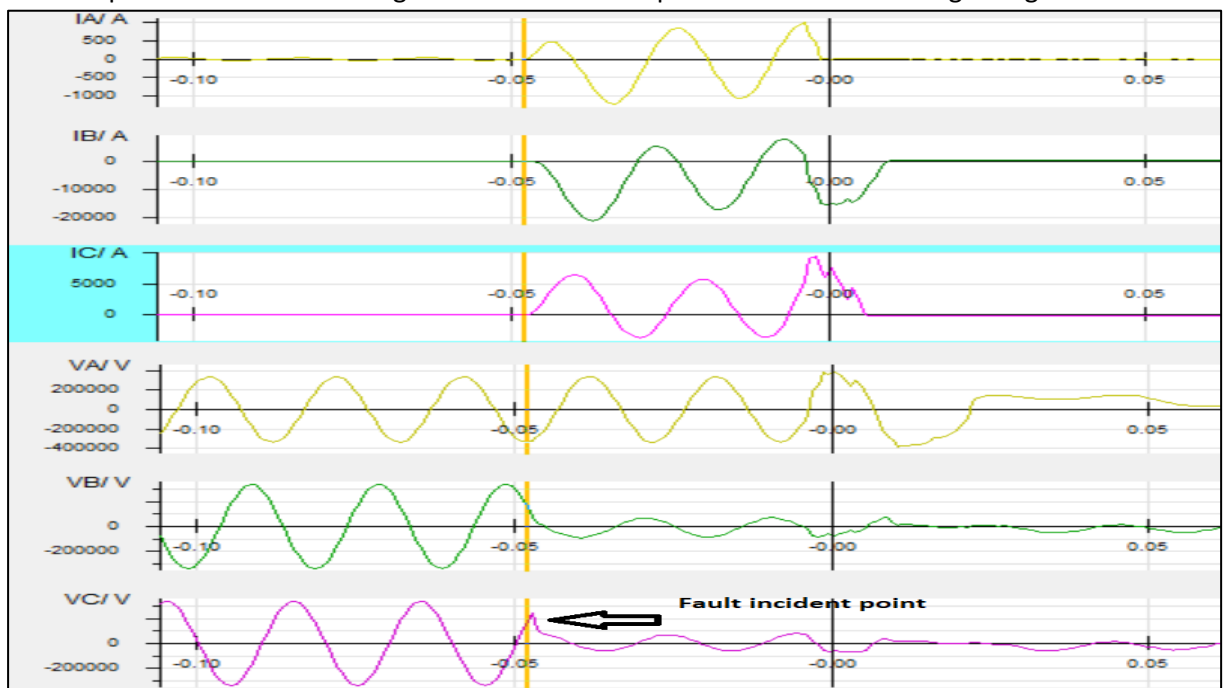

Hence Tower footing resistance, Sheilding/ground wire near the location may be checked to ensure.

Tripping of 400 kV Alipurdwar-Binaguri -I on O/V Stage-I

It has been observed that 400 Kv Binaguri-Alipurdwar-I is tripping on O/V STG-1 while there is no such actual overvoltage existing in the line . Details of tripping's are mentioned below along with DR plots .

Sr.No	Element Name	Tripping Date	Tripping Time	Reason
1	400 Kv Alipurdwar-Binaguri -I	29-06-2021	05:04	O/V Stage-I operated at Alipurdwar end.
2	400 Kv Alipurdwar-Binaguri -I	01-06-2021	01:05	O/V Stage-I operated at Alipurdwar end.
3	400 Kv Alipurdwar-Binaguri -I	22-04-2021	01:18	O/V Stage-I operated at Alipurdwar end.
4	400 Kv Alipurdwar-Binaguri -I	30-03-2021	03:41	O/V Stage-I operated at Alipurdwar end.

Alipurdwar & Binaguri end Line voltage comparison for 01 JUNE 2021:

For each tripping It is observed that Alipurdwar end Y phase voltage is 17 Kv higher than rest two phases ,while at Binaguri end no such thing observed .Which indicates that there is no such actual voltage rise existing in line due to mutual induction or transposition .DR Comparison shown below.

Hence there may be some issue with CVT and earthing at Alipurdwar end which needs to be checked and rectified.

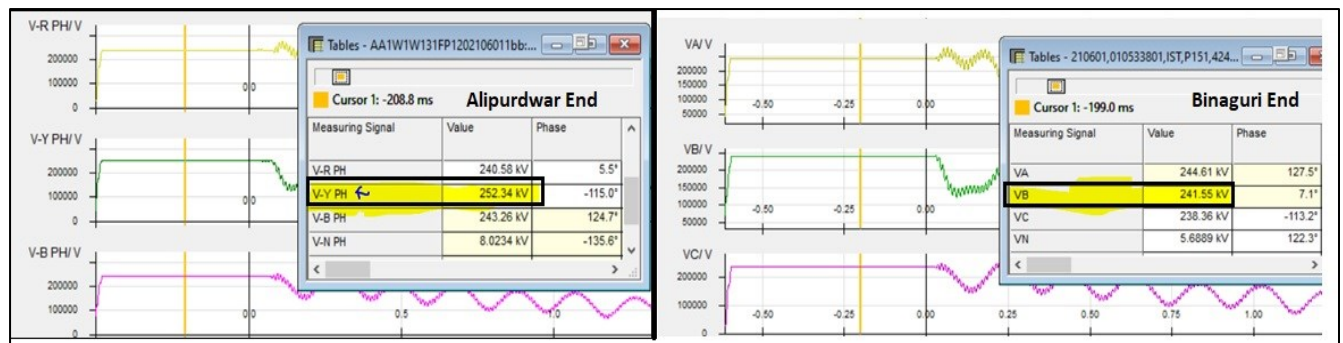

Alipurdwar & Binaguri end Line voltage comparison for 29 JUNE 2021:

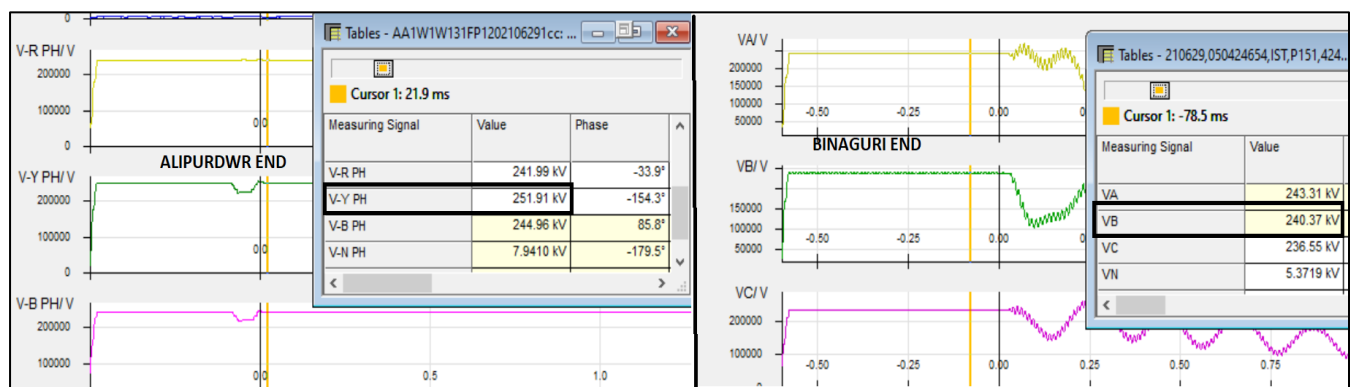

List of important transmission lines in ER which tripped in JUNE-2021

Annexure B.10

S.NO	LINE NAME	TRIP DATE	TRIP TIME	Relay Indication LOCAL END	Relay Indication REMOTE END	Reason	Fault Clearance time in msec	Remarks	PMU Location	DR/ELRECEIVED FROM REMOTE END	LOCAL END UTILITY	REMOTE END UTILITY	Utility to update	Utility Response	
1	400KV-MUZAFFARPUR-GORAKHPUR-1	06-01-2021	02:03	MFR: B-N, 60.78Km, 5.4kA		B-Earth	<100	B phase fault and B phase MCB &TCB tripped .B phase MCB A/R successful after 1 seconds but at 1.2 seconds again fault in reclaim time and all 3phase MCB got opened but rest 2 phase TCB was closed and after 2 seconds B phase TCB reclosed and got failed and ,3 phase TCB open .At the instance of fault in reclaim time all 3 phase MCB and TCB should have tripped,failing which caused repeated fault feeding .	MUZAFFARPUR	YES	NO	PG-ER-1	PG-ER-1	As relay is electromechanical in nature, thus no SOE to troubleshoot. Thus during SD of this line this problem will be attended. ALSO PO HAS BEEN PLACED FOR RETROFITTING THIS RELAY.	
2	400KV-BINAGURI-ALIPURDUAR (PG)-1	06-01-2021	01:05	Tripped on over voltage		O/V STG-1	NA	At Apd end Y phase voltage was 16 Kv higher than rest two phases and at Binaguri end voltage was normal .So at APD end CVT neutral earthing may be checked and overall cvt may also be checked.	BINAGURI	YES	YES	PG-ER-2	PG-ER-2	PG-ER-2	Cable damaged issue at APD end which has been replaced .
3	400KV-MAITHON-DURGAPUR-1	06-01-2021	15:51	MAITHON END:- R-N, 7.39KA, 38.6KM	DURGAPUR END:- R-N, 8.07KA, 21.0KM	R-Earth	<100	Seems 3 phase tripping from Maithon end while at Durgapur end 3 phase A/R after 1 second.	MAITHON	YES	NO	PG-ER-1	DVC	PG-ER-2	Old electromechanical relay related issue.
4	220KV-PUSAULI-DEHRI-1	06-01-2021	14:25	pusauli:- B-N FAULT 18.7KM 5.76KA	DEHRI-Z1, BN, 35.91km, 2.55KA	B-Earth	<100	No A/R attempted	SASARAM	NO	YES	BSPTCL	PG-ER-1,BSP TCL	A/R L/O OPTD AS BOTH PLCC IS UNHEALTHY. PLCC BELONGS TO BSPTCL.	

5	400KV-BARH-MOTIHARI-1	06-02-2021	20:49		Motihari end-Z1 Y-N FD-22.7km FC-7.57kA	Y-Earth	<100	At Barh end A/R attempted after 1.75 sec and got failed reason may be explained.	BARH	YES	NO	NTPC	DMTCL	NTPC BARH	
6	400KV-LAPANGA-OPGC (IB THERMAL)-1	06-11-2021	15:54	Lapanga: Z-1, R-Ph, 2.37kM, If=25.52kA		R-Earth	<100	3 PHASE TRIPPING from Lapanga end .No A/R reason may be shared.	MERAMUNDALI	YES	NO	OPTCL		OPTCL	
7	400KV-JHARSUGUDA(GIS)-OPGC-1	06-12-2021	17:06	JSC: A/R successful, R-N, 51.35Km, 6.5kA	OPGC: R-N, 3.6Km, 21.59kA	R-Earth	<100	A/R successful from only Jharsuguda end.	JHARSUGUDA	YES	NO	PG-ER-3	OPTCL	OPTCL	
8	400KV-MAITHON-MAITHON RB-1	15/06/2021	15:43	RB end- Z1 Y-n FD-17.4km FC-10.044kA	Maith PG-AR successful	Y-Earth	<100	A/R successful from PG end,	MAITHON	YES	NO	MPL	PG-ER-1	MPL	
9	400KV-GOKARNA-SAGARDIGHI-2	17/06/2021	13:11	GORKARNA:- R-N, Z-1 , 25.41KM, 10.24KA,	SAGARDIGHI:- Z-1. R-N, 4.388KM, 15.28KA	R-Earth	<100	All 3 phase TCB open at Sagrdighi end at the instance of fault ,while only MCB R phase open and ,A/R attempted and unsuccessful .	FARAKKA	YES	YES	WBSE TCL	WBPDC L	WBPDC L	
10	220KV-CHANDIL-RANCHI-1	22/06/2021	12:59	Ranchi: Y_N, 15.8 KM, 6.1 kA,A/r successful from Ranchi only		Y-Earth	500	Fault in z-1 from ranchi and z-2 from chandil.Ranchi end sent carrier still chandil end tripped after z-2 time .Whether PLCC link is unhealthy?	RANCHI	YES	YES	JUSNL	PG-ER-1	JUSNL .PG-ER-1	NEW ABB PLCC CARD FAILURE AT CHANDIL END AND MATTER REPORTED TO ABB FOR ITS REPLACEMENT.THERE WILL BE NO LINE S/D REQUIRED FOR CARD REPLACEMENT WORK.HOWEVER NEW CARD WILL BE SUPPLIED BY OEM MAY TAKE 2 MONTHS.
11	400KV-RANCHI-RAGHUNATHPUR-2	24/06/2021	11:57	Ranchi: B-N Fault, FD: 53km, FC: 5.152 KA	A/R SUCCESSFUL AT RTPS END	B-Earth	<100	3 phase tripping from Ranchi without A/R while RTPS end A/R successful.	MAITHON	YES	NO	PG-ER-2	DVC	PG-ER-1	POWER SWING DETECTED IN Z1. HOWEVER POWER SWING MOVEMENT FROM Z2 TO Z1 TOOK PLACE WITHIN 30MS, THUS 3 PH TRIPPING
12	220KV-NEW PURNEA-MADHEPURA-1	26/06/2021	10:35	NEW PURNEA: B-N, Z-1, FD: 82.7kM, FC:	Madhepura: B-N, Z1 ,12.3km	B-Earth	500	Fault in z-2 from purnea ,but carrier not receipt from madhepura although it was sent .Plcc healthiness may be checked.	PURNEA	YES	YES	PG-ER-2	BSPTCL	BSPTCL	

Annexure C.3

Comparison of Transformer OC and EF setting Philosophy of Different Utilities(Individual setting philosophies are attached in the annexure) :---

Protection Function	Feature	DVC	CESC	POERGRID	WB
HV/LV side OC stage 1	Directionality	No directional	No directional	Forward	Forward
	Setting are calculated based on fault level of Other side bus of ICT in same Substation	Yes	Yes	Yes	Yes
	Fault level of Remote end Substation also considered in the setting	No	No	No	No
	Coordinated with Remote end substations Line's zone-3 time	Yes	Yes	Yes	Yes
	Time	IEC normal inverse	IEC normal inverse	IEC normal inverse	IEC normal inverse
HV/LV side OC stage 2	Directionality	Not Used	Not Used	Non directional	Non directional
	Setting are calculated based on fault level of Other side bus of ICT in same Substation			No	No
	Fault level of Remote end Substation also considered in the setting			No	No
	Time			Definite	Definite
HV/LV side EF stage 1	Directionality	No directional	No directional	Forward	Disabled
	Setting are calculated based on fault level of Other side bus of ICT in same Substation	Yes	Yes	Yes	
	Fault level of	No	No	No	

	Remote end Substation also considered in the setting				
	Coordinated with Remote end substations Line's zone-3 time	Yes	Yes	Yes	
	Time	IEC normal inverse	IEC normal inverse	IEC normal inverse	
HV/LV side EF stage 2	Directionality	Not used	Not used	Non directional	Disabled
	Setting are calculated based on fault level of Other side bus of ICT in same Substation			No	
	Fault level of Remote end Substation also considered in the setting			No	
	Time			Definite	
Transformer Thermal over loading	Directionality	Not used	Not used	Non directional	Non directional
	Tripping/Alarm			Alarm only	Alarm only
	Time			Definite time ,	Definite time

Recommendation:

- HV/LV Directional over current low set (stage-1):** For upcoming projects and projects going for R &M may set it as follows:

Direction- Forward (towards transformer)

MTA/RCA- for cross polarization may be set as per OEM recommendation

P.S.-- 130 to 150% of transformer rated current

Characteristics- IEC normal inverse

TMS- Should be calculated considering LV/HV bus fault level and must be coordinated with remote substation zone-3 time.

TMS HV/LV

$$\frac{(\text{Remote end Z3 time} + \text{safety margin of 0.1 to 0.2 sec}) * \left(\left(\frac{\text{Fault current for LV/HV bus fault}}{\text{Pick up current}} \right)^{0.2} - 1 \right)}{0.14}$$

For existing projects their existing philosophy may be followed by the utilities however following must be ensured:

1. Protection coordination with remote end lines zone-3 time
2. Coordination with LV and HV side must be ensured for non-directional OC setting

2. HV/LV Directional over current high set (stage-2): For upcoming projects and projects going for R &M may set it as follows:

Direction- Non-directional

MTA/RCA- NA

$$P.S.-- = 110 * \frac{MVA \text{ rating}}{\% \text{ impedance} * \text{volatge} * 1.732}$$

Characteristics- Definite time 30-50 ms

Choice of utilizing the same setting is left with the utilities.

For existing projects their existing philosophy may be followed by the utilities however following must be ensured:

1. Coordination should be such that it should not trip for close in line fault before the line tripping

3. HV/LV earth fault low set:

From the analysis of the all utilities practice it is seen that the setting are consistent with the upper limit as proposed in the OCC meeting. However in the lower limit side it is not directly ensured that for a remote end substation fault the same will not pick up as shown below.

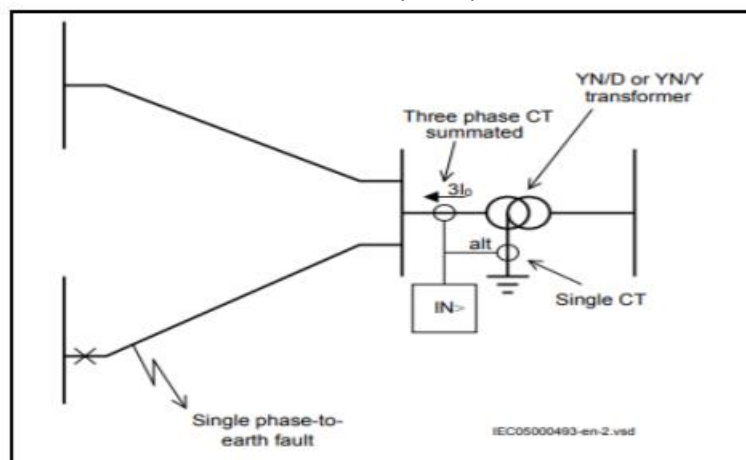

Following the DVC's practice the line DEF and Transformer DEF can be coordinated. The overall recommendation is as follows for the satge-1 setting:

Direction- Forward (towards transformer)

MTA/RCA- for cross polarization may be set as per OEM recommendation

P.S.-- 20 to 50% of transformer rated current. However it must be greater than all line's DEF setting connected to LV/HV side of the Transformer taking into account the applicable ratio correction.

Characteristics- IEC normal inverse

TMS- Should be calculated considering LV/HV bus fault level and must be coordinated with remote substation zone-3 time.

If REF is used then the choice of implementing the above protection may be left with the utility.

TMS HV/LV

$$\frac{(\text{Remote end Z3 time} + \text{safety margin of 0.1 to 0.2 sec}) * ((\frac{\text{Fault current for LV/HV bus fault}}{\text{Pick up current}})^{0.2} - 1)}{0.14}$$

For existing projects their existing philosophy may be followed by the utilities however following must be ensured:

1. Protection coordination with remote end lines zone-3 time
2. Coordination with LV and HV side must be ensured for non-directional EF setting. In case of non-directional setting, its pick up should be greater than all connected lines in both HV and LV bus.

4. HV/LV Directional over current high set (stage-2): For upcoming projects and projects going for R &M may set it as follows:

Direction- Non-directional

MTA/RCA- NA

$$\text{P.S.--} = 110 * \frac{\text{MVA rating}}{\% \text{ impedance} * \text{volatge} * 1.732}$$

Characteristics- Definite time 30-50 ms

Choice of utilizing the same setting is left with the utilities.

For existing projects their existing philosophy may be followed by the utilities however following must be ensured:

1. Coordination should be such that it should not trip for close in line fault before the line tripping

5. Transformer overload protection:

Direction- Non directional

P.S.- 110 to 120 % of transformer rated current

Characteristics- Definite time and alarm only

TMS- As per transformer OEM guideline or as per utilities choice.

Annexure-1: POWERGRID setting guide line for Transformer OC and EF:

400/220kV and 220/132kV transformer over current setting

HV side Protection:

a) HV Directional over current low set

Direction- Forward (towards transformer),

MTA or RCA – OEM specific

for GE: (+ve) 60 deg for cross polarization,

for ABB: (+ve) 65 deg for cross polarization

P.S.- 150% of transformer rated current,

Characteristics- IEC normal inverse,

TMS- TMS shall be such that for fault in remote end bus, relay shall issue trip command after Zone-3 timing of downstream line = (Zone-3 Timing + 0.1 sec) x { (IFault / Ipickup)^{0.02 -1} }/0.14

b) HV Directional over current high set

Direction- Non-directional,

MTA or RCA - NA

P.S.- 110% of Max. Current of Transformer in HV side = 110% * {(MVA rating / % Imp.) / (1.732 * Voltage)}

Characteristics- Definite time

TMS- 50ms

c) HV Directional earth fault low set

Direction- Forward (towards transformer)

MTA or RCA - (-ve) 45 deg for zero seq. polarisation

P.S.- 20% of transformer rated current

Characteristics- IEC normal inverse,

TMS- TMS shall be such that for fault in remote end bus, relay shall issue trip command after backup earth fault of downstream line = (Z3 timing + 0.2 sec) x { (IFault / Ipickup)^{0.02 -1} }

d) HV Directional earth fault high set

Direction- Non-directional,

MTA or RCA - NA,

P.S.- 110% of Max. Current of Transformer = 110% * {(MVA rating / % Imp.) / (1.732 * Voltage)}

Characteristics- Definite time

TMS- 50ms

LV side Protection:

e) LV Directional over current low set

Direction- Forward (towards transformer)

MTA or RCA - OEM specific

for GE: (+ve) 60 deg for cross polarization,

for ABB: (+ve) 65 deg for cross polarization

P.S.- 150% of transformer rated current

Characteristics- IEC normal inverse

TMS- TMS shall be such that for fault in remote end bus, relay shall issue trip command after Zone-3 timing of upstream line = (Zone-3 Timing + 0.1 sec) x { (IFault / Ipickup)^{0.02 -1} } / 0.14

f) LV Directional over current high set

Direction- Non-directional

MTA or RCA - NA

P.S.- 110% of Max. Current of Transformer in LV side = 110% * {(MVA rating / % Imp.) / (1.732 * Voltage)}

Characteristics- Definite time

TMS- 50ms

g) LV Directional earth fault low set

Direction- Forward (towards transformer)

MTA or RCA - (-ve) 45 deg for zero seq. polarisation

P.S.- 20% of transformer rated current

Characteristics- IEC normal inverse,

TMS- TMS shall be such that for fault in remote end bus, relay shall issue trip command after backup earth fault of downstream line = (Z3 timing + 0.2 sec) x { (IFault / Ipickup)^{0.02 -1} }

h) HV Directional earth fault high set

Direction- Non-directional,

MTA or RCA - NA,

P.S.- 110% of Max. Current of Transformer = 110% * {(MVA rating / % Imp.) / (1.732 * Voltage)}

Characteristics- Definite time

TMS- 50ms

i) Transformer overload protection

Direction- Non directional

P.S.- 110% of transformer rated current

Characteristics- Definite time

TMS- 5 sec.

Alarm only

j) VTS for directional o/c. relay

VTS status – blocking,

VTS mode –auto,

VTS Time delay – 5 Sec

**Annexure-2: West Bengal setting guide line for Transformer OC and EF:
400/220kV and 220/132kV transformer over current setting**

- a) **HV Directional over current low set**
Direction- Forward (towards transformer)
MTA- 45 deg lead for cross polarisation
P.S.- 150% of transformer rated current
Characteristics- IEC normal inverse 3 sec
TMS- Should be calculated considering 220kV bus fault to trip within 800 ms.

- b) **HV Directional over current high set**
Direction- Forward (towards transformer)
MTA- 45 deg lead for cross polarisation
P.S.- More than maximum current of the transformer due to 220kV fault
Characteristics- Definite time
TMS- 40ms

- c) **HV Directional earth fault-** Disabled

- d) **LV Directional over current low set**
Direction- Forward (towards transformer)
MTA- 45 deg lead for cross polarisation
P.S.- 150% of transformer rated current
Characteristics- IEC normal inverse 3 sec
TMS- Should be calculated considering 400kV bus fault to trip within 800 ms.

- e) **LV Directional over current high set**
Direction- Forward (towards transformer)
MTA- 45 deg lead for cross polarisation
P.S.- More than maximum current of the transformer due to 400kV fault
Characteristics- Definite time
TMS- 40ms

- f) **LV Directional earth fault-** Disabled

- g) **Transformer overload alarm**
Direction- Non directional
P.S.- 110% of transformer rated current
Characteristics- Definite time
TMS- 5 sec.

VTF for directional o/c. relay

1) VTF should be enabled

Protection should be blocked during VTF

Annexure-3: DVC setting guide line for Transformer OC and EF: ICT/ATR Back-Up setting philosophy practised in DVC

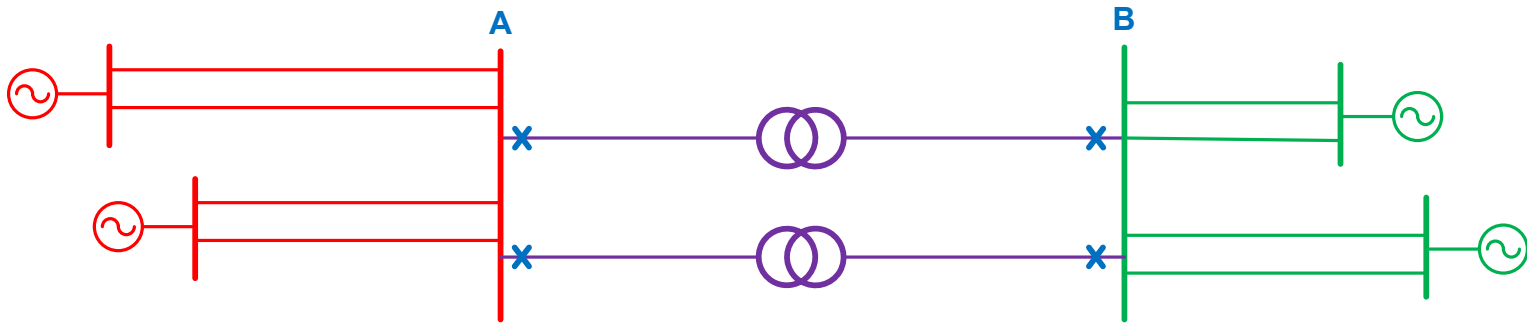

Points to be considered while deciding the back-up settings of the ICT:-

1. It should be checked that remote end Z#3 settings of lines connected to Bus A & B does not encroach to the next voltage level.
2. Same should be satisfied during different contingency conditions at Bus A & B.

Pick-Up Values:-

1. Over-Current Protection:- At least 135% of the rated current on HV side and 130% of the rated current on the LV side of the transformer.
2. Earth-Fault Protection:- HV side Earth Fault pick-up shall be more than or equal to the maximum earth-fault pick-up value of HV side transmission lines at local bus.

LV side Earth Fault pick-up shall be more than or equal to the maximum earth-fault pick-up value of HV side transmission lines at local bus

Back-Up Setting Philosophy for the ICT relay at end 'A':-

1. For a bus fault at end 'B', the relay at end 'A' shall operate 150-200 ms after the Z#3 delay settings of the lines connected to Bus-B.
2. With the same setting parameters as decided above, the operation delay of the relay at end 'A' is checked for a bus fault at Bus-A, because relay at end A is non-directional. If the relay operating time is 150-200 ms more than Z#3 delay settings of the lines connected to Bus-A then setting parameters decided above in point no.1 are kept as the final settings. However if the relay operates earlier, then the time dial settings of the ICT relay at end 'A' is increased by such an amount that it operates 150-200 ms after the Z#3 time delay of the lines connected to Bus-A.

Back-Up Setting Philosophy for the ICT relay at end 'B':-

1. For a bus fault at end 'A', the relay at end 'B' shall operate 150-200 ms after the Z#3 delay settings of the lines connected to Bus-A.
2. With the same setting parameters as decided above, the operation delay of the relay at end 'B' is checked for a bus fault at Bus-B, because relay at end B is non-directional. If the relay operating time is 150-200 ms more than Z#3 delay settings of the lines connected to Bus-B then setting parameters decided above in point no.1 are kept as the final settings. However if the relay operates earlier, then the time dial settings of the ICT relay at end 'B' is increased by such an amount that it operates 150-200 ms after the Z#3 time delay of the lines connected to Bus-B.

Annexure-4: CESC setting guide line for Transformer OC and EF:

Over Current Setting Philosophy of ICTs

a) HV (220kV Side) over current Setting Philosophy

Type: Non Directional

P.S.- 142% to 150% of transformer rated current

Characteristics- IEC normal inverse 3 sec

TMS- Should be calculated considering bus fault at 132kV Side as well as 33 kV Bus Fault.

b) IV (132kV Side) over current Setting Philosophy

Type: Non Directional

P.S.- 142% to 150% of transformer rated current

Characteristics- IEC normal inverse 3 sec

TMS- Should be calculated considering bus fault at 33 kV .

c) LV (33kV Side) over current Setting Philosophy

Type: Non Directional

P.S.- 150% to 160% of transformer rated current

Characteristics- IEC normal inverse 3 sec

TMS- Should be calculated considering Outgoing Feeder fault at 33 kV .

Earth Fault Setting Philosophy of ICTs

a) HV (220kV Side) Earth Fault Setting Philosophy

Type: Non Directional

P.S.- 20% to 50% of CT rated current

Characteristics- IEC normal inverse 3 sec

TMS- Should be calculated considering bus fault at 132kV Side .

b) IV (132kV Side) Earth Fault Setting Philosophy.

Type: Non Directional

P.S.- 20% to 50% of CT rated current

Characteristics- IEC normal inverse 3 sec

TMS- Should be calculated considering Outgoing Feeder fault at 132 kV .

c) LV (33kV Side) over current Setting Philosophy

Type: Non Directional

P.S.- 20% to 40% of CT rated current

Characteristics- IEC normal inverse 3 sec

TMS- Should be calculated considering Outgoing Feeder fault at 33 kV .



ଓଡ଼ିଶା ବିଦ୍ୟୁତ ଶକ୍ତି ସଂଚାରଣ ନିଗମ ଲିଡ.

ODISHA POWER TRANSMISSION CORPORATION LIMITED

(A Government of Odisha Undertaking)

Regd. Office: Janpath: Bhubaneswar

CORPORATE IDENTITY NUMBER (CIN) U40102OR2004GC007553

Telephone: 0674-2541168

Fax:

Connect us Facebook/optcl.odisha - Twitter/optcl_odisha

No. : Dir (O) - *Lead flow study-2/2021-80* Date : *29.06.2021*

To

The Member Secretary,
Eastern Regional Power Committee,
14 Golf Club Road, Tollygung, Kolkatta-700033.

Sub:- Transmission Planning for Intrastate constraints in Odisha System.

Ref:- Your Letter No. ERPC/OPERATION/2021/264 dt. 25.05.2021.

Sir,

Inviting reference to the above OPTCL has conducted an in-house system study for Long Term planning to mitigate the constraints at power evacuation from Budhipadar Grid substation. The brief report on transmission planning for intrastate constraints in Odisha system in Budhipadar command area is enclosed for kind reference.

Yours faithfully,

Encl: As above.

[Signature]
29/6/2021
Director (Operation)

C.C.

1. Director (SLDC) for information.
2. PS to MD OPTCL for kind information of MD.

BRIEF REPORT ON TRANSMISSION PLANNING FOR INTRASTATE CONSTRAINTS IN ODISHA SYSTEM

System study has been conducted to see the power flow in transmission lines in Budhipadar and Tarkera command area during the steady state and in contingency conditions.

Assumptions.

Vedanta export has been shown as 150 MW/ckt & 90 mw/ckt.

Bhushan drawl has been taken as 90 MW.

RSP drawl has been taken as 100 MW.

The flows are tabulated below.

Condition	Bisra-Tarkera	Budhipadar-Tarkera	Vedanta-Budhipadar	Budhipadar-Lapanga	BudhipadarAuto	Bhushan drawl
Base Case	106MW/Ckt	74 MW/Ckt	150 MW/Ckt	155 MW/Ckt	106 MW each	90 MW
Bisra-Tarkera S/C out	188 MW	78 MW/Ckt	150 MW/Ckt	151.8 MW/Ckt	106 MW each	90 MW
Budhipadar-Tarkera S/C out	125 MW/Ckt	90 MW	150 MW/Ckt	171 MW/Ckt	110 MW each	90 MW
Vedanta-Budhipadar S/C out	106 MW/Ckt	73 MW/Ckt	296 MW	155 MW/Ckt	106 MW each	90 MW
Outage of Tarkera-Bonei & Tarkera-Chandiposh	81 MW/Ckt	66.8 MW/Ckt	150 MW/Ckt	160 MW/Ckt	106 MW each	90 MW
Vedanta export 180 MW	117 MW/Ckt	62 MW/Ckt	90 MW/Ckt	130 MW/Ckt	102 Mw each	90 MW
Vedant export 180 MW+Tarkera-Bonei & Tarkera-Chandiposh out	94 MW/Ckt	56 MW/Ckt	90 MW/Ckt	135 MW/Ckt	102 MW each	90 MW
Vedanta export 180 MW+Tarkera-Bonei& Tarkera-Chandiposh	55 MW/Ckt	96 MW/Ckt	90 MW/Ckt	0	145 MW each	90 MW

out+Budhipadar-Lapanga D/C out						
Vedanta-Budhipadar D/C out	135 MW/Ckt	46 MW/Ckt	0	92 MW/Ckt	96 MW each	90 MW
Vedanta-Budhipadar D/C out & Bisra-Tarkera 4 ckts	71.5 MW	42 MW/ckt	0	95 MW/ckt	96 MW each	90 MW

Conclusion

With Unified Vedanta i.e. getting disconnected from Budhipadar and connected through ICT to 400 kV Sterlite, the Bisra-Tarkera 220 kV DC line is loaded 135 MW each thus violating the n-1 criteria.

When Vedanta export is limited to 180 MW, the Budhipadar-Lapanga & Bisra-Tarkera line loading violates n-1 criteria.

As a short term measure when the Bisra-Tarkera Ckt drawl increases beyond thermal limit, Barkote, Bonei and Chandiposh may be disconnected from Tarkera end allowing it to draw from Rengali end thus relieving Bisra-Tarkera line loading.

At present Budhipadar is having one 160 MVA transformer. The second Auto transformer of 160 MVA will be commissioned by the end of Aug'2021.

In a futuristic scenario i.e. during 2022-23 condition, the Bisra-Tarkera DC line is loaded 152 MW each. Hence another DC line from Bisra-Tarkera will mitigate the loading condition.

Vedanta will be allowed to be disconnected from Budhipadar thus facilitating unification only when Bisra-Tarkera will be augmented with another DC line. Loading of all the lines emanating from Budhipadar and Tarkera will be n-1 compliant. The preliminary survey for another two Ckts from Bisra to Tarkera has started.