



**AGENDA  
FOR  
186<sup>th</sup> OCC MEETING**

**Date: 22.12.2021**

**Eastern Regional Power Committee**

**14, Golf Club Road, Tollygunge**

**Kolkata: 700033**

## **EASTERN REGIONAL POWER COMMITTEE**

**AGENDA FOR 186<sup>TH</sup> OCC MEETING TO BE HELD ON 22.12.2021 (WEDNESDAY) AT 10:30 HRS**

### **PART – A**

**ITEM NO. A.1: Confirmation of Minutes of 185<sup>th</sup> OCC Meeting held on 23<sup>rd</sup> November 2021 through MS Teams online platform.**

The minutes of 185<sup>th</sup> Operation Coordination sub-Committee meeting held on 23.11.2021 was circulated vide letter dated 06.12.2021.

Members may confirm the minutes of 185<sup>th</sup> OCC meeting.

### **PART B: ITEMS FOR DISCUSSION**

**ITEM NO. B.1: Removal of technical minimum schedule support from ISGS plants to facilitate full surrender of power by Constituents.**

As per prevailing practice in Eastern Region, ISGS stations are provided with Technical Minimum schedule support. In the event where sum of requisition from all the beneficiaries falls below technical minimum, the beneficiary schedule is jacked up to provide technical minimum schedule to the generators.

However, in the light of recent CERC Order on Petition No: 60/MP/2019, the practice of jacking up surrendered schedule of beneficiaries shall be withdrawn, except in cases as mandated in Section 5.7 of detailed Reserve Shutdown Procedure (RSD) (CERC Order No. - L-1/219/2017-CERC), which states:

#### *Quote*

*RLDC shall Suo-moto revise the schedule of any generating station as per clauses 6.5.14 and 6.5.20 of the Grid Code to operate at or above technical minimum in the ratio of under-requisitioned quantum (with respect to technical minimum) in the interest of smooth system operation under the following conditions:*

- ✓ *Extreme variation in Weather Conditions*
- ✓ *High Load Forecast*
- ✓ *To maintain reserves on regional or all India basis*
- ✓ *Network Congestion*
- ✓ *Any other event which in the opinion of RLDC/NLDC shall affect the grid security.*

*While doing so, it is possible that the requisition of some beneficiaries may go up to ensure technical minimum. In this case, SLDCs may surrender power from some other inter-State generating station(s) or intra-State generating station(s) based on merit order. The concerned RLDC shall issue R-1 schedule accordingly and this shall be intimated to the concerned generating station, through the scheduling process.”*

*Unquote.*

In the 184<sup>th</sup> OCC meeting, ERLDC representative submitted that as per the existing practice if the sum of requisition from all the beneficiaries falls below the technical minimum, then in order to ensure that the units continue to run on bar, RLDC jacks up the schedule of the beneficiaries thereby providing technical minimum to the generators. However, as per CERC Order on Petition No: 60/MP/2019, there should not be any jacking up by the RLDCs, except for some special conditions. If the requisition falls below the technical minimum, then at that instance the concerned generators may run their unit at reduced generation or may go for RSD. He further added that the Generators may also approach the beneficiaries and request them to increase their requisition in case the sum of requisition from all the beneficiaries falls below the technical minimum.

NTPC representative submitted that if technical minimum is not allowed for only few blocks, then either the concerned beneficiaries may increase their requisition to support the technical minimum of the generators or jacking up of the schedule for those time blocks may be done from RRAS.

SE (Comm), ERPC submitted that concerned generators may go for RSD if they don't get the technical minimum. He further added that in such scenarios the beneficiaries need to understand that if any unit goes under RSD, then it will take a considerable amount of time to revive the unit and in that case if the beneficiaries need any power, then they will have to depend on the market. Further he submitted that as per the prevailing regulation, RRAS can only be implemented where there is any increase/decrease in grid frequency or any major congestion in the transmission network happens.

Odisha representative opined that if any of the beneficiaries doesn't support the technical minimum and surrenders its power, then the other beneficiary (ies) may use that power thereby providing technical minimum to the generator(s). In that case only the variable cost/energy charge would be levied on the beneficiary (ies) who availed that power. The beneficiary (ies) surrendering the power would bear only the fixed charge. He further added that the same has also been discussed in WRPC forum.

After detailed deliberation, OCC opined that:

- The existing practice would be continued until a decision is taken.
- In the meantime, Odisha would submit a detailed proposal along with the WRPC's decision before the next OCC for further deliberation on the matter.

In the 185<sup>th</sup> OCC meeting, ERPC representative briefly explained the issue stating that whenever the sum of the requisitions given by the beneficiaries fall below the technical minimum, to keep the generator on bar RLDC jacks up the schedule, because of which some of the beneficiaries are being scheduled against their zero requisition. It was also stated that as per the CERC order on Petition No: 60/MP/2019, the jacking up of the schedule is to be discontinued except on some special occasions. Further, as per the discussions in the CERC meeting with RPCs held on 17.11.2021 regarding the agenda "Issue related to Reserve Shutdown (RSD) of ISGS station", it was informed that necessary amendment in the IEGC Grid Code shall be incorporated by Hon'ble CERC to address this issue.

ERPC representative further submitted that until such amendment in the IEGC, the above issue may be addressed in 3 ways.

1. Generator may go on RSD and in that case, it may take considerable amount of time to revive the unit and in case beneficiaries need any power they would have to approach the market.

2. Continuation of the existing practice of jacking up of the schedule.
3. A mutual agreement may be worked out in which the beneficiary(s) who are ready to avail the URS power to keep the generator on bar, may be incentivised by waiving off the fixed charges up to the technical minimum schedule.

ERLDC representative informed that the existing regulations clearly deliberate that it is up to the generator(s) to decide whether to keep the unit in reserve shutdown or not. Moreover, if the beneficiaries agree, a collaborative method as suggested by ERPC may be chalked out in this forum to address the issue for the time being.

NTPC representative submitted that if any beneficiary opts to surrender the power, then only its co-beneficiaries i.e., the original allottees, are only eligible to avail the surrendered power. NTPC representative further stated that this exercise may not be applicable in case the beneficiary(s) of a generator belongs to the jurisdiction of some other region and may not agree upon waiving off of fixed cost charges up to the technical minimum and in such cases consent from other RPCs may have to be taken.

Bihar representative mentioned that the existing practice of jacking up of the schedule is beneficial for them.

Jharkhand representative informed that consent from their DISCOM has to be taken regarding this matter.

SLDC Odisha submitted that they are ready to waive off the fixed charges for those beneficiaries who avail the URS power up to the technical minimum schedule.

After detailed deliberation OCC opined that since the above issue involves some commercial implications, therefore it may be deliberated further in a separate forum to reach a final consensus. OCC advised all the Constituents to forward their views and comments to ERPC Secretariat within 10 days. A separate physical meeting would be convened for further deliberation of the issue.

**Members may discuss.**

## **ITEM NO. B.2: Islanding Schemes in Eastern Region.**

### **B2.1. Implementation of Islanding Schemes in Eastern Region**

In the meeting held on 28<sup>th</sup> December 2020 and chaired by the Hon'ble Minister of State (IC) it was directed that islanding schemes should be implemented for all major cities of the country considering all the strategic and essential loads. Subsequently, in line with the direction given in the meeting, the subject matter was discussed in PCC meeting of ERPC and it was finalized that new islanding scheme would be implemented for capital city of Patna & Ranchi.

#### **I. Patna Islanding Scheme:**

In the special meeting held on 06.08.2021, it was decided that Patna islanding scheme would be designed considering two unit of Nabinagar STPP (2\*660 MW) of NPGCL as participating generator and loads of in and around Patna city. The provision of island formation with one unit of NPGC with corresponding load is also to be included in the island logic.

The islanding frequency & logic will be finalized based on the result of dynamic study to be

carried out by SLDC Bihar/ERLDC.

The following timelines were decided:

1. Submission of requisite information by SLDC, Bihar: 2nd week of Aug' 2021.
2. Completion of Islanding simulation study by ERLDC: 4th Week of Aug' 2021
3. Review of islanding study & designing of the logic: By September'2021
4. Implementation & Operationalization of the Islanding Schemes: By March'2022

In 106<sup>th</sup> PCC meeting held on 16.09.2021 it was informed that the requisite information had already been shared by SLDC Bihar and the study is under progress by ERLDC. Further SLDC Bihar was advised to prepare the DPR by September'2021 for PSDF funding, if required.

In the 44<sup>th</sup> TCC Meeting, BSPTCL updated that preparation of DPR for PSDF funding is under process and the same would be completed within 15 days.

TCC stressed on the fact that this issue is being regularly monitored by MoP and advised BSPTCL for timely implementation of the Islanding Scheme.

In the 184<sup>th</sup> OCC meeting, BSPTCL representative submitted that M/s Siemens would give a presentation on DPR by Oct'21 end and subsequently the DPR would be prepared by 1<sup>st</sup> week of November'2021.

OCC advised BSPTCL to expedite the matter with Siemens and prepare the DPR as per the said schedule without any further delay.

In the 185<sup>th</sup> OCC meeting, BSPTCL representative mentioned that presently M/s Siemens is carrying out some tests for the preparation of DPR which is scheduled to be completed by last week of November'2021. As soon as the proposal from M/s Siemens is received, they would place the order.

OCC expressed serious concern over the issue and advised BSPTCL to expedite the matter with M/s Siemens at the earliest.

**BSPTCL may update.**

## **II. Ranchi Islanding Scheme:**

In the special meeting held on 06.08.2021, it was decided that Ranchi islanding scheme would be formed with one unit of Tenughat TPS (150-160 MW average generation) & Inland IPP (50-55 MW average generation) as participating generator & essential/critical loads of Ranchi to the tune of 180 MW. The islanding frequency & logic will be finalized based on the result of dynamic study to be carried out by SLDC Jharkhand/ERLDC.

The following timelines were decided:

1. Submission of requisite information by SLDC, Jharkhand: 2nd week of Aug' 2021.
2. Completion of Islanding simulation study by ERLDC: 4th Week of Aug' 2021
3. Review of islanding study & designing of the logic: By September'2021
4. Implementation & Operationalization of the Islanding Schemes: By February'2022

In 106<sup>th</sup> PCC meeting held on 16.09.2021 it was informed that the requisite information had

already been shared by SLDC Jharkhand and the study is under progress by ERLDC. Further SLDC Jharkhand was advised to prepare the DPR by September'2021 for PSDF funding, if required.

In the 44<sup>th</sup> TCC Meeting, JUSNL updated that preparation of DPR for PSDF funding is under process and the same would be completed within 15 days.

TCC stressed on the fact that this issue is being regularly monitored by MoP and advised JUSNL for timely implementation of the Islanding Scheme.

In the 184<sup>th</sup> OCC meeting, JUSNL representative submitted that they had requested for budgetary offer from GE, Siemens and ABB and after getting the same they would prepare the DPR.

OCC advised JUSNL to expedite the work and prepare the DPR within the stipulated time frame.

In the 185<sup>th</sup> OCC meeting, JUSNL informed that the tender for DPR would be opened on 25<sup>th</sup> Nov 2021.

**JUSNL may update.**

**In addition to above new islanding schemes, the following schemes have already been finalized and under different stage of implementation:**

### **III. Chandrapura Islanding Scheme:**

The scheme detail in brief is as follows:

- The CTPS-B islanding scheme is to be designed with two units of CTPS-B (2x250 MW) generating station as participating generator and connected loads at CTPS, Putki, Biada, Nimiaghata & Patherdih. The estimated off-peak and peak load in the proposed islanding system is 280 MW & 420 MW respectively.
- The islanding frequency for CTPS-B islanding system was decided as 48.4 Hz.

In special meeting held on 06.08.2021, following deliberations took place:

Representative of SPE wing of DVC updated that necessary discussion for implementation of the scheme at CTPS-B is going on with M/s GE for finalization of the scope of work & other modalities. He submitted that the tender process for implementation of islanding scheme would be initiated within two weeks.

In the 44<sup>th</sup> TCC Meeting, DVC representative informed that the work order for implementation of Chandrapura Islanding Scheme would be placed by March-2022 and the same would be implemented within 6 months.

In the 184<sup>th</sup> OCC meeting, DVC representative submitted that the scope of work has already been finalized but the budgetary offer is yet to be received from GE & Siemens. He further intimated that after getting necessary details from GE and Siemens, approval from their appropriate authority would be taken.

On query, he submitted that they are following up the matter with Siemens and GE on daily basis and stated that they would resolve the issue within one week.

OCC advised DVC to update the status to ERPC and ERLDC.

In the 185<sup>th</sup> OCC meeting, DVC representative informed that the scope of work and scheme for the islanding of CTPS unit # 7 & 8 has been prepared and the budgetary offer from M/s Siemens & M/s GE has also been collected. The scheme would be finalized within 2-3 months and subsequently the tendering process would be initiated.

OCC advised DVC to complete the work within the stipulated time period.

**DVC may update.**

#### **IV. KBUNL Islanding Scheme:**

In special meeting held on 08.06.2021, following deliberations were made:

1. KBUNL Islanding scheme would be designed considering both units of KBUNL stage-II (2x195 MW) as participating generator and connected radial loads at Gopalganj along with in-house load of KBUNL.
2. The islanding frequency will be at 48.6 Hz and this is subject to revision based on the suggestion received from KBUNL/OEM on under frequency settings of the generator units.
3. KBUNL would expedite the construction work related to implementation of Islanding scheme in switchyard. They would also take up with concerned OEM for testing and commissioning of islanding relay panel at their end.

In 106<sup>th</sup> PCC Meeting following deliberations were took place -

Regarding bay construction work at KBUNL switchyard, NTPC informed that civil work would be completed by October-21 & further testing & commissioning would be completed by January-21.

ERPC secretariat informed that time line for implementation of KBUNL islanding scheme had been decided as December-21 and advised NTPC to complete the bay construction work as well as other pending works related to implementation of the islanding scheme at the earliest.

In the 44<sup>th</sup> TCC Meeting, NTPC representative informed that the Islanding Scheme would be implemented by February-2022.

TCC advised NTPC representative to share the detailed timelines for completion of the remaining work to ERPC.

TCC further advised NTPC to implement the KBUNL Islanding Scheme as per the timeline.

In the 184<sup>th</sup> OCC meeting, KBUNL representative submitted that 4 nos. of bays are under erection, however, the civil work for construction of Bus-sectionalizer is under progress and after completion of the same erection work would be started.

Further, KBUNL representative expressed that the islanding frequency i.e., 48.4Hz, as proposed by ERLDC, needs to be reviewed as they have their low frequency tripping command at 48.5Hz. ERLDC representative advised KBUNL to consult with their OEM and OS and thereafter getting the inputs from OEM and OS the matter may be further discussed for finalization of the frequency.

In the 185<sup>th</sup> OCC meeting, KBUNL representative informed that the matter of islanding frequency has been taken up with their OS & OEM. Further, a meeting with ERLDC was also held wherein some issues were highlighted. After the receipt of final simulation study from ERLDC, the approval from their OS & OEM would be taken.



ERLDC submitted that KBUNL is a unit of less capacity (less than 200MW) and does not have either RGMO or FGMO mode of frequency response. Further, without any mode of governor response it is very difficult for the Islanding scheme to sustain. KBUNL has some mechanical form of governor response for which detailed modeling is not possible at ERLDC side. In view of the above ERLDC suggested KBUNL to carry out the simulation study through some other agencies.

On query, KBUNL representative informed that the bus sectionalizer bay is still under the process of erection because of hamper in civil works due to heavy rainfall. The work has been started since 1<sup>st</sup> Nov 2021 and would be completed in another 3-4 months.

**KBUNL may update.**

#### **V. IB-TPS Islanding Scheme:**

The scheme was finalized in the special Meeting on Islanding Scheme of IB-TPS held at ERPC, Kolkata on 12th December 2018.

In special meeting held on 06.08.2021, OPGC representative informed that work order had been placed on OEM (M/s BHEL) for implementation of the Islanding scheme at IB TPS units.

OPGC was also advised to take up the issue with their highest authority as well as with the OEM for expediting the implementation of islanding scheme.

In the 44<sup>th</sup> TCC Meeting, OPGC representative informed that IB TPS Islanding Scheme would be implemented as per the given timeline i.e., April-22.

In the 184<sup>th</sup> OCC meeting, OPGC representative informed that the erection and testing work has been completed. He further submitted that the islanding scheme would be implemented after consultation with OPTCL regarding the load details (144 MW).

OCC advised OPGC to update the status of their meeting with OPTCL regarding this to ERPC and ERLDC.

In the 185<sup>th</sup> OCC meeting, OPGC representative submitted that a meeting with OPTCL has been conducted on 11.11.2021 regarding erection and commissioning of DTPC at OPGC and Tarkera ends. The work has already been started at the Tarkera end and the whole work is scheduled to be completed by the end of December 2021.

OCC advised OPGC to complete the commissioning work of DTPC coupler at the earliest.

**OPGC may update.**

#### **B2.2. Separate Display of Islanding Schemes (IS) on SCADA of respective states LDCs/Sub SLDs and RLDCs**

Hon'ble Minister for Power and New & Renewable Energy had taken a meeting to review the Islanding Schemes in Indian Power system on 28<sup>th</sup> December 2020. Further, on 19<sup>th</sup> August 2021 Secretary, Ministry of Power had taken another meeting (MoM enclosed) in this regard wherein it was decided that for real time monitoring of participating generators & critical loads of Islanding schemes, a separate display of Islanding Schemes on SCADA of respective states LDCs/Sub SLDs and RLDCs may be prepared. Delhi SLDC and NAPS IS had already prepared the display page on their SCADA.



Separate displays of the Islanding Schemes on SCADA may be set up in the SLDCs/Sub SLDs and RLDCs.

In the 184<sup>th</sup> OCC meeting, OCC advised all the concerned state SLDCs to set up a separate SCADA display at their control room end so that the same can be extended to ERLDC. The display needs to be set up for both the existing and the proposed Islanding schemes.

OCC advised ERLDC SCADA representative to co-ordinate with the concerned utilities regarding the same.

In the 185<sup>th</sup> OCC meeting, ERLDC SCADA team informed that separate display for CESC islanding scheme has already been prepared. Necessary details of Farakka islanding scheme have also been received. Upon receipt of details from other concerned utilities, the separate display of SCADA for the respective islanding schemes would be set up.

OCC advised ERLDC SCADA team to implement the displays for the islanding schemes by December'2021.

**ERLDC may update.**

### **ITEM NO. B.3: Reliable Power Supply to Lalmatia/Godda/Dumka areas of JUSNL**

#### **B3.1. Restoration of 220kV Farraka-Lalmatia S/C line**

The 220 kV Farakka-Lalmatia S/C was out of service since April 2021 due to tower collapse. The 220/132/33 kV Lalmatia substation is relying on only 132 kV lines. At present the local load at 220 kV Dumka and Godda S/S were being radially fed from 400/220 kV Maithon S/S through 220 kV Maithon-Dumka D/C and 220 kV Dumka-Godda D/C.

In 181<sup>st</sup> OCC Meeting, JUSNL representative submitted that they had got a letter from NTPC on 19<sup>th</sup> July '21 regarding anti-theft charging of the 220kV Farraka-Lalmatia S/C line at 33kV level. Earlier the antitheft charging of the line was done at 11kV level but incidents of thefts have been reported in some portion of the conductor.

Further, Jharkhand representative requested NTPC to submit the details of the 33kV lines passing below 220kV Farakka-Lalmatia T/L. He added that as per information obtained from their JUSNL Discom part, the 33kV lines are mostly connected with 11kV feeders and due to this it would be difficult to charge the Farakka-Lalmatia line at 33kV level in Pakur area.

NTPC representative informed that they had charged the line up to loc no.241 but in between loc no.76-82 only the top conductor was in charged condition and the bottom rest were not; because of this theft might have happened in that portion. He further added that they had already isolated the section from loc no.76-82, whereas up to loc no.76 the line is in charged

Condition and from loc no.82-241 the line needs to be charged.

ERPC advised NTPC and Jharkhand to explore the possibility of antitheft charging at 33kV level first and if that is not feasible then charging at 11kV can be assessed.

In the meeting held on 10<sup>th</sup> August 2021 by the Hon'ble Secretary, Ministry of Power, Government of India, ECL was directed to handover the FLTS assets on "as is where is basis" to

JUSNL, the Operation and Maintenance whereof as was with the NTPC is also to be transferred to the JUSNL without any further delay and latest by 20th August 2021. Further JUSNL was directed to comply with all other directions of the CERC's order dated 21.07.2020, after the transfer of the FLTS from ECL.

In the 182<sup>nd</sup> OCC meeting, JUSNL representative submitted that the tripartite agreement for taking over of FLTS as well as O&M of FLTS is in process and the same would be done after getting the consent from the competent authority by 4<sup>th</sup> week of August'2021.

OCC advised JUSNL to expedite the work for anti-theft charging without any further delay. JUSNL representative ensured to do the same.

ERLDC representative advised JUSNL for putting 220kV Lamatia-Godda line into service. JUSNL representative informed that they had tried to charge the line once but due to voltage rise at Lalmatia end, they had to open the line.

OCC advised JUSNL to re-check the possibility of charging the 220kVLamatia-Godda line for reliable power supply to Lalmatia.

In the 184<sup>th</sup> OCC meeting, JUSNL representative submitted that the agreement has been signed among NTPC, ECL and JUSNL. He further intimated that a joint patrolling of the line is yet to be done by them.

ERLDC representative opined that restoration of the 10 nos. of collapsed towers may be done first on priority basis.

JUSNL representative stated that the estimate for restoration of the lines has already been approved by their BoD and Govt. of Jharkhand has been approached for fund requisition. In the meantime, the tendering process would be finalized and after getting the necessary fund approval the work order for the same would be placed.

On query, JUSNL representative ensured that the line would be restored by June'22.

In the 185<sup>th</sup> OCC meeting, JUSNL representative informed that fund requisition to their energy department has been requested on 8<sup>th</sup> Nov 2021 and the work would be started upon receipt of funds.

It was highlighted by OCC that restoration of the line to be taken on priority basis, since it serves commercial interest of Jharkhand by drawing power directly from Farakka STPS. Besides, restoration of the line would also improve reliability of power supply.

**JUSNL may update the status of restoration of line.**

### **B3.2. Commissioning of 220kV Tenughat-Govindpur line**

In 179<sup>th</sup> OCC meeting, ERLDC representative stressed over the fact that commissioning of 220kV Tenughat-Govindpur line would increase the system reliability and the said line may be commissioned at the earliest.

In 181<sup>st</sup> OCC Meeting, Jharkhand representative submitted that as per the information received from Powergrid the line would be ready by July'21 end and it would take another 15 days for

getting the necessary Statutory Clearance.

OCC advised Jharkhand to apply for the necessary Statutory Clearance in the meanwhile so that further delay can be avoided when the line gets ready. OCC advised Jharkhand to co-ordinate with Powergrid and get the said line ready by 15<sup>th</sup> August 21.

In the 182<sup>nd</sup> OCC meeting, JUSNL representative submitted that they had already got all the Statutory Clearance. He further added that only one railway crossing is pending which is expected to be completed by 10<sup>th</sup> Sept'21.

In the 183<sup>rd</sup> OCC meeting, JUSNL representative submitted that all pending work has been completed and final checking of the line is under progress.

They intimated that the line would be charged by first week of Oct'21.

In the 184<sup>th</sup> OCC meeting, JUSNL representative submitted that the line would be charged by 26.10.2021.

OCC advised JUSNL to update the status to ERPC and ERLDC.

In the 185<sup>th</sup> OCC meeting, JUSNL representative informed that one circuit has been commissioned on 3<sup>rd</sup> Nov 2021. Because of some breaker issues in the second circuit the commissioning is yet to be done. He further added that the commissioning would be done by 10<sup>th</sup> December'2021.

**JUSNL may update.**

### **B3.3. Status of O & M agreement with Powergrid for bay equipment at Maithon end and resolution of auto recloser issues in the 220 kV Maithon-Dumka Lines**

In 103<sup>rd</sup> PCC meeting, during discussion of tripping of 220 kV Maithon-Dumka line-2 on 15/05/21, it was informed that the auto-recloser in the said line is not in operation due to some issues in PLCC. It was also come to notice that there was no formal agreement between JUSNL & Powergrid for O & M of the bay equipment at Maithon end. As a result, bay equipment at Maithon end for 220 kV Maithon-Dumka D/C lines are not being maintained properly.

In 181<sup>st</sup> OCC Meeting, Jharkhand representative submitted that some queries along with few finance observations had been raised to Powergrid in this regard. However, complete reply from Powergrid side is yet to be received and as soon as they receive the response from Powergrid, they would proceed for the agreement. However, in principle they are ready for the agreement.

ERPC opined that as Farakka-Lalmatia line is not in service at present, Maithon-Dumka line is of vital importance and healthiness of PLCC at both ends is to be ensured.

OCC advised Jharkhand to take up the necessary rectification work for ensuring the healthiness of the PLCC. In this regard, Powergrid has also given consent to Jharkhand for the necessary PLCC work at Maithon end.

Jharkhand representative assured that the PLCC would be restored by 15<sup>th</sup> August 21.

In the 182<sup>nd</sup> OCC meeting, JUSNL representative submitted that Powergrid had submitted the revised estimate and the same is in the process for approval by competent authority. He further

informed that it would be completed by 1<sup>st</sup> week of September'2021.

In the 183<sup>rd</sup> OCC meeting, JUSNL representative intimated that in-principle approval for the O & M agreement had already been accorded to Powergrid. Further, signing of the agreement would be completed by September'21.

In the 184<sup>th</sup> OCC meeting, JUSNL representative submitted that the agreement would be signed after getting necessary approval from their Finance wing.

In the 185<sup>th</sup> OCC meeting, JUSNL representative informed that approval has been received from their finance department on 22.11.2021 and the agreement would be signed by 10<sup>th</sup> December 2021.

**JUSNL may update.**

**ITEM NO. B.4: Restoration of PLCC for 220 kV Chandil-STPS S/C line**

In 101<sup>st</sup> PCC meeting held on 13.04.2021, it was come to notice that both the channels of PLCC of 220 kV Chandil-Santalidih S/C line is unhealthy at Chandil end since May-2020. PCC advised JUSNL to rectify the PLCC issue at Chandil end at the earliest.

In 108<sup>th</sup> PCC meeting held on 16.11.2021, JUSNL representative informed that the PLCC rectification work could not be carried out as they are yet to receive the financial approval for the said work from their higher authority.

220 kV Chandil-STPS being an inter-state line and connected to generating station, healthiness of PLCC/line shall be ensured for overall reliability & security of the grid.

In the 185<sup>th</sup> OCC meeting, OCC expressed serious concern over the issue and advised JUSNL to update the status at the earliest.

**JUSNL may update.**

**ITEM NO. B.5: Outage of Important Transmission System.**

**B5.1. 132kV Sagbari–Melli.**

Sikkim vide mail dated 09.06.2021 updated the following status:

- 1) In loc 82,83 & 84 we have low ground clearance which need hill cutting but if needed TL can be charged after putting temporarily barbed wire fencing.
- 2) In loc 98-99 a house had been constructed just below the line and warning had been issued to the owner for not to do vertical extension of the house till any such arrangement is made.
- 3) In loc 116 &117 land owner demanding for intermediate tower and not allowing for us to clear the jungles.
- 4) Loc 128 is in dilapidated condition due to sinking effect posing threat to lives and properties. Local public are asking to shift the tower in safe place before restoration of supply in the TL.
- 5) 80% of jungle clearance has been completed and remaining 20% is in Forest area most of it is under west district and waiting for permission from Forest department.
- 6) The delay in obtaining permission for following trees in forest land is that it cannot be ascertained whether FCA clearance during construction of TL was obtained as the record is

7) not available either in power department or in DFO Office. Regarding this in the it had been told by ERPC that once obtaining environment clearance at the time of construction there need not to take permission for further clearance of ROW from Forest dept and this matter is been conveyed to the Forest department but they informed us as per Forest Act of Sikkim state permission has to be obtained for fresh felling with payment of compensation. File for approval is being send to conservator of Forest from DFO on 10/6/2021.

In the 181<sup>st</sup> OCC meeting, Sikkim representative submitted that for the rest 20% work, they are yet to get clearance from the Forest Department. He further informed that there are also some RoW issues in that portion of the line. Further, ERLDC representative stressed over the fact that being a very important line, the restoration of the 132kV Sagbari–Melli linemay be done at the earliest.

OCC advised Sikkim to take up the matter with Forest Department for obtaining necessary clearance and also to resolve the ROW issues without any further delay.

In the 182<sup>nd</sup> OCC meeting, Sikkim informed that the matter is under persuasion.

In the 184<sup>th</sup> OCC meeting, the agenda could not be discussed as Sikkim representative was not available in the meeting.

In the 185<sup>th</sup> OCC meeting, Sikkim representative was not available in the meeting.

**Sikkim may update.**

#### **B5.2. 220kV Pandiabili - Samangara D/C**

220kV Pandiabili-Samangara D/C line tripped on 03-02-2019 during the event of Fani due to Tower collapse. 48 no towers got fully damaged and 12 no towers got partially damaged. Presently the line is charged from Pandiabili end upto location no 58. It is a very important line for supplying power to Puri area. The line is under outage more than 2 years.

In the 182<sup>nd</sup> OCC meeting, OPTCL representative submitted that the restoration work for 220kV Pandiabili - Samangara D/C line has been assigned to Powergrid. He further added that redesigning of tower in view of change of wind zone from Zone 4 to Zone 6 has also been taken up by Powergrid.

On query, OPTCL representative informed that the line is expected to be restored by March'2022.

ERLDC representative expressed that as 220kV Pandiabili - Samangara D/C line is of utmost important; thus, the restoration of the said line may be expedited.

OCC advised OPTCL to expedite the work and also advised OPTCL to submit the work schedule mentioning the timelines for completion of designing, procurement and erection activities to ERPC and ERLDC.

In the 183<sup>rd</sup> OCC meeting, OPTCL representative informed that design of all the tower foundations

of subjected line has been changed from open cast to pile foundation-based tower. Therefore, the restoration of the line would take considerable time. He submitted that restoration of the line is expected by June'23.

OCC advised OPTCL to submit the action plan along with the time line for restoration of the line.

In the 184<sup>th</sup> OCC meeting, OPTCL representative submitted that the restoration work has been undertaken by Powergrid.

He added that DA & DD type tower design has already been tested and passed by CPRI, however, the prototypes of DB & DC type tower are under testing. Once the testing of the same is successfully completed, the action plan of the restoration work would be submitted by Powergrid.

OCC advised OPTCL to share the action plan to ERPC & ERLDC.

In the 185<sup>th</sup> OCC meeting, OPTCL representative informed that permission for testing of type DB & DC towers has been taken from CPRI but the tentative timelines for completion of test are yet to be received from CPRI.

**OPTCL may update.**

### **B5.3. 440/220kV 315 MVA ICT 2 at Meramundali:**

400KV/220KV 315 MVA ICT 2 at Meramundali tripped on 21-02-2021 due to fire hazard at Meramundali SS. The ICT is under outage since then. Meramundali S/S is serving the important load of the Odisha. Long outage of an ICT at such crucial S/S may hamper the reliability of the Grid.

In the 182<sup>nd</sup> OCC meeting, OPTCL representative submitted that the old ICT, which was completely damaged, would be replaced by a new one. The new 315 MVA ICT of BHEL make has already arrived at site and the foundation modification work is going on. OPTCL representative stated that the replacement work is expected to be completed by 30th Nov'21.

OCC advised OPTCL to expedite the work and also to share the work schedule of the same to ERPC & ERLDC for effective monitoring of the same.

In the 183<sup>rd</sup> OCC meeting, OPTCL representative submitted that the foundation work has been completed and the remaining work is expected to be completed by Nov'21.

In the 184<sup>th</sup> OCC meeting, OPTCL representative submitted that the work would be completed by December'21. He further mentioned that representative of BHEL (OEM) is yet to visit the site, however, the civil construction work has been completed and the said transformer is on the plinth.

OCC advised OPTCL to expedite the work and complete it by 31<sup>st</sup> Dec'21.

In the 185<sup>th</sup> OCC meeting, OPTCL representative informed that they are in constant touch with the OEM and after receipt of some of the materials at the site the erection work is expected to be completed by the end of December 2021.

OCC advised OPTCL to expedite the matter with the OEM and complete the work at the earliest.

**OPTCL may update.**

### **B5.4. Outage of 400kV Main Bus-2 at Dikchu HEP.**

400kV Main Bus-2 at Dikchu HEP has been out since 05.05.2021.

Dikchu main update the expected restoration date & work progress regarding restoration.

In the 185<sup>th</sup> OCC meeting, Dikchu representative was not available in the meeting.

Dikchu vide mail dated 27.11.2021 informed that, on 07.09.2021 a test had been conducted by them to pin point the fault location. Subsequently, the fault was found in the B phase Circuit Breaker Compartment of 400 KV Dikchu-Teesta 3-line bay 403.

So as suggested by the OEM, there was a need to replace the CB compartment.

In this regard, the offer for new CB compartment from OEM GE(T&D) had already been received on 15<sup>th</sup> Nov' 21. The procurement process is in progress & the works are being planned to be carried out in 3rd week of Jan' 22.

**Dikchu HEP may update.**

#### **B5.5. Prolonged outage of Bus-2 at Rangit HEP.**

During providing shutdown of different elements around Rangit complex, ERLDC came to know that one bus of Rangit (Bus-2) is out since long. Such prolonged outage of one bus at important ISGS power station is an issue of concern for grid security. NHPC is requested to provide the details of outage and restoration plan for same.

**Rangit HEP may update.**

<b>ITEM NO. B.6: Inadequate reactive power performance of generating units during the high voltage condition.</b>
---

Since 180<sup>th</sup> ER OCC meeting, ERLDC highlighted the issue of inadequate reactive power absorption by generating units during the high voltage condition. Due to inadequate reactive power absorption by generating units, voltage at various 400 kV and 765 kV remained high. As per ERLDC SCADA data, following regional generating units' (ISGS & IPP) reactive power absorption was inadequate during November 2021.

<b>Name of generating units</b>	<b>Maximum MVar absorption limit (as per capability curve)</b>	<b>MVar absorption during maximum voltage (as per ERLDC SCADA data)</b>	<b>Maximum voltage during November 2021</b>
Talcher STPS Stage I – 500 MW unit 1 & 2	> 150 MVar	0 -10 MVar	410 kV
Barh STPS Unit - 4	>220 MVar	< 50 MVar	420 kV
Nabinagar TPP Stage I - 250 MW Unit - 1 (BRBCL)	> 120 MVar	<20 MVar	409 kV
Nabinagar TPP Stage I - 250 MW Unit -2 & 3 (BRBCL)	>120 MVar	<0 MVar (unit was generating 0-30 MVar)	412 kV
Nabinagar STPP Stage – 1 660 MW Unit - 1	>250 MVar	<70 MVar	418 kV
JITPL - 600 MW Unit – 1 &2	> 200 MVar	0 MVar (Unit was generating 120 MVar)	415 kV



- Performance of Barh generating unit was satisfactory during earlier months. However, performance of unit 4 was non satisfactory during the month of November 2021.
- Significant MVAR absorption has been observed for Talcher Stage II units. However, MVAR absorption by Talcher Stage I units was not satisfactory.

**NTPC Talcher, NPGC, BRBCL & JITPL may share the reason for consistent non-satisfactory performance and actions taken so far. NTPC Barh may share the reason for poor performance during November 2021.**

**ITEM NO. B.7: Agenda by OPTCL**

**B7.1. Splitting of Budhipadar 220kV Bus due to high fault level.**

OPTCL vide mail dated 30.08.2021 submitted that the fault level at Budhipadar 220 kV bus during steady state is 42.79 kA which is beyond the breaker rating of 40 kA. OPTCL has conducted the system study and the study reveals that in the base case the fault level is 42.79 kA while during splitting the fault level at the two buses are 30.40kA and 12.72kA. ERPC may advise suitable scenario to mitigate the fault level at Budhipadar.

In the 183<sup>rd</sup> OCC meeting, OPTCL informed that the fault level at 220 kV Budhipadar S/s is found to be crossed more than 42 kA and there are multiple generating units connected to 220 kV buses. In order to reduce the fault level, they proposed to segregate the 220 kV bus & connected feeders by opening the bus coupler breaker. In this regard they had carried out a study.

ERLDC pointed out that the proposal of segregating the bus by opening of bus coupler breaker reduces the overall reliability of the system.

OPGC informed that in the given study all four evacuating lines from IB TPS is connected to same bus at Budhipadar thereby affecting the reliability of the evacuation of IB TPS generation in case of any bus fault at Budhipadar.

ERPC secretariat informed that as per the decision taken in the special meeting on "implementation of SPS at Budhipadar S/s" the 220 kV Vedanta-Budhipadar D/C is to be made off after commissioning of second 220/132 kV ATR at Budhipadar and as such Vedanta injection at Budhipadar shall not be considered in the study. Further on suggestion of proper bus split at Budhipadar by bus-sectionalizer, OPTCL submitted that it would take considerable time to implement the proper bus splitting scheme.

After detailed deliberation, OCC advised OPTCL to carry out revised study in consultation with OPGC & SLDC Odisha for different scenarios and submit the report to ERPC/ERLDC for further discussion in this regard.

**B7.2. Splitting of Meramundali 220 kV Bus due to high fault level.**

OPTCL vide mail dated 15.09.2021 submitted that the fault level at Meramundali 220 kV bus during steady state is 40.89 kA which is beyond the breaker rating of 40 kA. OPTCL has already conducted the system study. However, ERPC may advise suitable scenario to mitigate the fault level at Meramundali.

In the 183<sup>rd</sup> OCC meeting, after detailed deliberation, OCC advised OPTCL to carry out revised study in consultation with OPGC & SLDC Odisha for different scenarios and submit the report to ERPC/ERLDC for further discussion in this regard

In the 184<sup>th</sup> OCC meeting, OPTCL representative submitted that due to the ongoing festive month, meeting with OPGC and SLDC Odisha could not be convened. He further intimated that a meeting would be convened by 1<sup>st</sup> week of November'2021 and the outcome of the meeting would be shared with ERPC & ERLDC.

In the 185<sup>th</sup> OCC meeting, OPTCL representative informed that the meeting with OPGC & SLDC Odisha is yet to be convened and is scheduled to be held by the end of November 2021. He further stressed on the fact that if all the four lines are connected to the same bus the issue of power evacuation through IB TPS generation would persist. Therefore, in order to balance the load and generation the bus coupler is kept in open condition. He further submitted that the 2<sup>nd</sup> auto transformer is at the final stage of erection at Budhipadar S/s and after commissioning of the same, a joint discussion may be carried out to discuss the matter of bus splitting.

ERLDC representative mentioned that opening the bus coupler to reduce the fault level critically hampers the reliability aspect and OPTCL along with its beneficiaries may discuss upon formulating suitable plans like installation of bus sectionalizer, up gradation of circuit breakers, bus augmentation, etc. for the implementation of bus splitting scheme.

OCC opined that the fault level at Budhipadar is very high and action has to be taken to reduce the same. OCC further advised OPTCL to convene a joint meeting along with its beneficiaries to explore the possibilities of finding a permanent solution to the above problem.

**OPTCL may update.**

## **ITEM NO. B.8: Islanding incidents in CESC system**

### **B8.1. Islanding Performance and Observations during recent Islanding incidents in CESC system**

CESC islanding performance and frequency variation for past few Islanding events were checked for Island stability. Based on the analysis by ERLDC, possible challenges for island survival are listed below.

- Oscillating Variation of frequency after island formation in Budge-budge frequency is observed up to (0.5-1 Hz) and was varying continuously till it got synchronized with grid at Howrah point.
- In event 3, Budge-Budge Unit generation was also oscillating and its root cause needs to be looked into which is ultimately driving the frequency of island.
  
- Any cyclic load changes or other behavior within the island need thorough analysis as these may also be the source of observed variation. Variation of traction and Metro load may also be studied within the island as it impacts on overall frequency stability within the islanded system.
- Under frequency load shedding setting as shared within the island starts from 49.4 Hz and may cause operation of UFR relay in some cases inside the island. This would be detrimental for island survival as observed for 2 events, Frequency dipped up to 49.5 & 49.6 Hz due to these variations.
- Above observation and frequency variation pattern was also observed during event of 28<sup>th</sup> April 2020.

Detailed report is attached at **Annexure B8.1.**

In the 184<sup>th</sup> OCC meeting, CESC representative submitted that their team would visit ERLDC on 27<sup>th</sup> Oct'21 for detailed discussion on the incidents.

In the 185<sup>th</sup> OCC meeting, CESC representative informed that their team had already visited ERLDC and a follow up team comprising of senior officials would visit ERLDC by 1<sup>st</sup> week of December'2021 for further deliberation in the matter.

The Minutes of the Meeting held between the officials of ERLDC & CESC on 30.11.2021 is attached at **Annexure B8.1.1.**

**CESC may update.**

**B8.2. Low frequency oscillation observed on 20th September 2021 due to Budge-Budge Plant of CESC.**

Low Frequency Oscillation of 0.875 Hz was observed between 03:53 Hrs. to 03:57 Hrs. on 20<sup>th</sup> Sept 2021 near Subhasgram area. The magnitude of oscillation was maximum near Subhasgram and started reducing on moving away from Subhasgram. Observed LFO was of Local mode which indicates that the oscillation initiated with hunting of any nearby unit.

It was observed that maximum variation in MW oscillation was observed for Budge-budge units, which appears to be the source of oscillation. It was also observed that as MW of units reduced at Budge Budge units, this oscillation also damped.

Detailed report from ERLDC is attached at **Annexure B8.2.**

In the 184<sup>th</sup> OCC meeting, CESC representative submitted that their team would visit ERLDC on 27<sup>th</sup> Oct'21 for detailed discussion on the incidents.

In the 185<sup>th</sup> OCC meeting, CESC representative informed that their team had already visited ERLDC and a follow up team comprising of senior officials would visit ERLDC by 1<sup>st</sup> week of December'2021 for further deliberation in the matter.

The Minutes of the Meeting held between the officials of ERLDC & CESC on 30.11.2021 is attached at **Annexure B8.1.1.**

**CESC may update.**

**ITEM NO. B.9: Event of Smelter Load tripping at Sterlite CPP on 20<sup>th</sup> & 28<sup>th</sup> September 2021**

Smelter load tripping of 400 kV Sterlite CPP was observed on two occasions i.e., on 20 & 28th September 2021 due to electrical disturbance in the downstream side which resulted into Smelter load reduction of more than 1000 MW.

- This has caused under drawl of Odisha by more than 1000 MW. Subsequently with SPS action at Sterlite, injection to grid was limited up to 800 MW.
- Intimation of such events is necessary in real time as grid flow pattern gets affected considerably and also this is important for frequency response assessment purpose.

Report by ERLDC is attached at **Annexure-B9.**

In the 184<sup>th</sup> OCC meeting, ERLDC representative submitted that due to the Smelter load tripping at Sterlite CPP, there was huge under drawl on that day. Odisha tried to mitigate the problem by reducing their hydro but the under drawl persisted for more than one hour.

Odisha representative mentioned that they had taken remedial actions like reducing the hydro generation but still the issue of under drawl persisted. He further added that the matter would be discussed with their higher authority and the details of the same would be shared with ERPC and ERLDC by 10<sup>th</sup> November'21.

OCC advised Odisha to send their action plan regarding mitigating the above-mentioned issue so that it can be discussed further in next OCC.

In the 185<sup>th</sup> OCC meeting, SLDC Odisha representative informed that a meeting with OPTCL would be convened to discuss the issue and based on the discussion of the meeting; necessary action plan regarding the issue would be shared to ERPC/ERLDC.

OCC advised SLDC Odisha to take up the matter with OPTCL at the earliest and send the detailed report so that it can be discussed in the upcoming OCC meeting.

**SLDC Odisha may update.**

**ITEM NO. B.10: Technical overview of AMR Data Center hardware and application refreshment program for Eastern Region**

AMR Hardware and Software/ Application installed and running since 2013 at ERLDC for all the constituents of ER. All the Hardware equipment installed in the system has already elapsed almost 08 Years and being IT equipment, as per present CERC regulation already usable life is consumed.

Accordingly for running the system smoothly, with latest Cyber security aspects/compliances, both, Hardware and Software refreshment is required. New Hardware will be installed as per the CEA/CERC guideline for IT Network equipment along with New AMR application will be developed, with latest JAVA version and new features.

In view of above, M/S. TCS shall deliver a presentation on above for better understanding. Further, after finalization of technical aspects/features, necessary commercial offer shall be submitted.

In the 184<sup>th</sup> OCC meeting, Powergrid representative submitted that AMR Hardware and Software/ Application which have been running since 2013 at ERLDC for all the constituents of ER became old and have already consumed its usable life. He also added that as per CERC guidelines regarding Cyber security aspects/compliances both the Hardware & Software need to be updated.

M/s TCS representative gave a brief presentation on the same.

OCC agreed to give go ahead to Powergrid for finalizing the technical aspects so that financial cost assessment can be done. Powergrid representative informed that they would provide the cost estimate for the up-gradation project within 10 days.

Further, OCC advised Powergrid to co-ordinate with ERLDC for finalization of the technical aspects.

In the 185<sup>th</sup> OCC meeting, Powergrid representative informed that after having several meetings

with M/s TCS a preliminary offer for both software and hardware part has been received amounting to Rs. 1 Crores 14 Lakhs. He added that for the detailed technical study another 1-week time would be required.

**Powergrid may update.**

**ITEM NO. B.11: Repeated trippings of generating units.**

During November & December (till 16<sup>th</sup>) 2021, following generating stations tripped repeatedly due to the reasons mentioned hereunder:

Name of unit	No of tripping	Major reasons for repeated tripping
JITPL - UNIT 2	7	5 times turbine tripping issue, Bottom ash issue, Bottom oil low
BARAUNI TPS - UNIT 9	4	BTL, Problem in GT, AUX Power Failed
STERLITE - UNIT 4	3	HP Bypass valve issues, Pa Fan tripped, APH Problem
TENUGHAT - UNIT 1 & 2	3&2	2 times low drum level, Unit 2 on both times BTL
BARH -UNIT	2	Both times Boiler Tube Leakage

In the 185<sup>th</sup> OCC meeting, WBPDC representative submitted that they are in discussion with their Operation Engineers regarding repeated tripping of the unit.

OCC advised concerned generators to take necessary steps in order to avoid these kinds of repeated trippings.

**Respective generating units may update.**

**ITEM NO. B.12: Agenda by TPTL.**

With reference to the 185<sup>th</sup> OCC Shutdown meeting dated 18.11.2021 wherein the shutdown of 400 kV D/C Teesta-III – Kishanganj Transmission Line viz. CKT – I (B), CKT -I (C) & CKT -II from 16.12.2021 to 24.12.2021 was approved by ERLDC. The Shutdown is requested by PGCIL ER-II for completing LILO works of 400 kV Teesta III – Kishanganj line at Rangpo substation. Currently in the existing transmission system CKT-I of the transmission line is LILO at Rangpo Sub-station (current SLD diagram of the Transmission line is attached). As a consequence of LILO of CKT-II of the line, transmission tower(s) 99 to 113 of the 400kV Teesta-III – Kishanganj Transmission line will be rendered inoperative. The said transmission towers were constructed by TPTL after facing huge ROW challenges. Due to non-operation of the encompassing section of the line between these towers, the said section is at risk of theft. The said towers are a part of an important ISTS line of the Eastern Region and shall be kept safeguarded for any future utilization purpose. It is requested that a suitable arrangement may be planned by the nodal authority to keep the section of the line safeguarded from theft. The probable revised schematic arrangement of the line after the completion of LILO works is attached as **Annexure B.12**.

**Members may discuss.**

**ITEM NO. B.13: Frequent Grid disturbance in OPTCL's (STU) 220KV network.**

Odisha Power Generation (OPGC) is operating its 2x210 MW units at IB Thermal Power Station, Banharpali, Jharsuguda. The entire capacity has been allocated to GRIDCO. The units have been operating since the year 1994. The electrical power from the plant is being evacuated to OPTCL's 220KV Budhipadar substation at Jharsuguda through OPTCL's 02 nos. 220KV D/C line.

In this reference the grid failure (black out) has happened 3 times this year (2021). The details of the tripping are mentioned below.

SL No.	TRIP DATE	TRIP TIME	CAUSE OF TRIPPING
1	08-Apr-21	14:07	<ul style="list-style-type: none"><li>• At our end Distance Protection Zone – 2, Zone – 3 &amp; directional Earth Fault Initiated in all four outgoing lines.</li><li>• Both Unit-01 &amp; 02 tripped on over frequency protection.</li></ul>
2	09-Oct-21	11:57	<ul style="list-style-type: none"><li>• At our end Directional Earth fault initiated in all three IB-Budhipadar outgoing lines (Lin-01, Line-03 &amp; Line-04). IB-Budhipadar Line-02 tripped on distance protection zone-1 (fault loop: L1-N).</li><li>• Both unit-01 &amp; 02 tripped on over frequency protection.</li></ul>
3	30-Nov-21	10:12	<ul style="list-style-type: none"><li>• At our end “zone-2 start” &amp; “zone-3 start” initiated in all four IB-Budhipadar outgoing lines (Line-1, Line-2, Line-3 &amp; Line-4).</li><li>• Both Unit-1 &amp; 2 tripped on “over frequency” protection.</li></ul>

This type of disturbance puts thermal, electrical and mechanical stress on our Power plant equipment which is affecting the reliability of the plant and also the life cycle of the equipment.

**Members may discuss.**

**ITEM NO. B.14: PLCC issue in 400 KV Baripada-Kharagpur T/L**

In reference to the MOM of 184th OCC under SI no (6) of item B9, PLCC related issues were discussed in reference to the Kharagpur-Baripada 400 kV line. SLDC, WB urged for following the

all over India trend to settle the issue of who will rectify / replace the PLCC panels in respect to the mentioned line. PowerGrid Orissa urged for following precedence for rectification / changing of PLCC panels at both ends by WBSETCL. The same was reflected in the minutes.

However, on careful scrutiny for other tie lines, it was noticed that normally the maintenance, fault rectification, panel replacement types of jobs for PLCC panel etc. are done by the utilities at their

respective ends. For example, in case of STPS-Chandil line, JSEB is maintaining their end PLCC portion and WB for STPS end part.

Hence, continuing the same logic of SLDC, WB as was mentioned in 184th OCC, that different rules for different tie lines are not desired. So, the all-India trend should be maintained for the Kharagpur-Baripada line also. Hence for changing the panels at Baripada end, Power Grid may please take up the matter, and WB will take care of the Kharagpur end panel replacement work to make both channels available and reliable.

In the 185<sup>th</sup> OCC meeting, West Bengal representative pointed out that different practice of maintenance for different tie lines is not desirable and there is a need for streamlining the procedure for all the tie lines. He further submitted that irrespective of the ownership of the PLCC, the maintenance work may be carried out by the utilities at their respective ends.

Powergrid Odisha representative stressed upon the fact that the maintenance work of both ends may be carried out by the respective owners of the PLCCs.

OCC opined that a uniform methodology has to be implemented for the maintenance of all the tie lines. OCC advised Powergrid representative to take up the matter with their higher management and share their views with ERPC for further deliberation on the issue.

Powergrid Odisha vide mail dated 25.11.2021 informed that the said PLCC panels at baripada are WBSETCL's property. Further the following details mentioned below were also furnished by Powergrid Odisha.

#### **PART-I**

1. 400 kV Rengali-Kolaghat line was pre-existing before LILO of the same at Baripada in 2005. During this LILO, PLCC panels at Rengali were diverted to Baripada Ss for PLCC link of Baripada-Kolaghat Line.
2. These panels were maintained by Gridco at Rengali S/s before diversion to Baripada Ss and were supposed to be maintained by GRIDCO at Baripada Ss after the said diversion.
3. These were old ABB make PLCC Panels.
4. IOM dtd 05.09.2009 by CM (O&M) Baripada to CM (OS), ER-II, Kolkata and Fax dtd 25.04.2005 from DGM Baripada to GM (Telecom), GRIDCO are relevant references for above mentioned details. Scan copy attached for reference.

#### **PART-II**

1. WBSETCL commissioned 400 kV Kharagpur Substation in 2012 by making LILO of the existing 400 kV S/C Baripada-Kolaghat line at Kharagpur.
2. During the above LILO, existing ABB PLCC panels meant for earlier Baripada-Kolaghat line was replaced by BPL Make PLCC Panels.
3. Fresh PLCC arrangement at Baripada Ss for above 400 kV Baripada-Kharagpur line was taken up by WBSETCL through their vendor M/s Alstom. Letter from M/s WBSETCL to POWERGRID vide letter no. TR. PROJ. /T-181/20 dtd 11.04.2012 is attached for reference.
4. The frequencies to be set for above PLCC link were communicated to Baripada Ss by M/s WBSETCL through Letter No. C/ED/PLCC/PGCIL/Kharagpur dtd 30.08.2010. Scan copy attached.



Further, it has also been learnt from previous employees posted at Baripada Ss that revenue bifurcation for maintenance of PLCC at Baripada Ss by POWERGRID has not been done and that the response from Kharagpur end for any rectification of PLCC panels for subject line was poor.

**Members may discuss.**

**ITEM NO. B.15: VAR injection at high voltage-Odisha**

There is a sizable VAR flow from 400 KV Indravati PH bus to Indravati PG at high voltage i.e., above 103%. All attempts have already been made to reduce this VAR injection by SLDC Odisha, but because of no generation of Indravati PH the lines inject the VAR at high voltage.

Thereby it is proposed to discuss and deliberate upon switching off the 400 KV Indravati PH-PG tie line to avoid this huge revenue loss. All other outlets of Indravati PH shall be in service and in no case reliability and system security shall be compromised.

In reference to the above GRIDCO has paid around Rs. 7.98 Crores during the FY 2021-22 (till 24.10.2021) towards reactive energy charges to ERPC Reactive pool A/c as per provisional reactive energy (VARH) charges statements published in the ERPC website. It is to mention that during the months of Apr'20 to Oct'20 during FY 20 21, GRIDCO had paid Rs. 4.36 Cr towards reactive energy charges to ERPC Reactive Pool A/c. Thus, it is evident that the reactive energy charges have increased in FY 21-22 during the same time frame of previous FY 20-21. Hence, immediate necessary action may please be taken to nullify the reactive charges burden on GRIDCO.

In the 185<sup>th</sup> OCC meeting, Odisha representative informed that huge penalty in the form of reactive energy charges is being paid by them because of increase in VAR injection at high voltage (above 103%). Therefore, in order to minimize this revenue loss, the 400 KV Indravati PH-PG tie line may be switched off.

OCC opined that a detailed study/analysis may be undertaken by ERLDC and thereafter a decision would be taken regarding this matter.

**Members may update.**

**ITEM NO. B.16: Exemption of loss of DC on ground of Force Majeure situation - DVC.**

Due to a flood-like situation in the Bankura district and Asansol because of the incessant rainfall on 29.09.2021 to 30.09.2021 owing to the formation of a low-pressure area created over Gangetic West Bengal. The unprecedented rainfall in the lower valley area of DVC caused inundation in Mejia Thermal Power Station (MTPS) & Durgapur Steel Thermal Power Station (DSTPS).

In this context OS&U Dept., DVC has requested for exemption of loss of DC of MTPS#1,2,4 & 8 and DSTPS#1,2 on ground of force majeure condition. The appeal along with the relevant data and documentary proof of the above inundated condition, furnished by OS&U Dept. DVC, is hereby attached as **Annexure B.16**.

In view of the above, OS&U Dept, DVC has requested for kind vetting of force Majeure condition by ERPC for subsequent certification of the requested DC from SLDC, DVC end.

**Members may discuss.**

**ITEM NO. B.17: Proactive measures in Gandak Embankment for protection of Motihari LILO line**

DMTCL vide letter dated 13.12.2021 submitted the following:

This is an advance intimation on a new issue that could potentially impact the Barh-Motihari and Motihari-Gorakhpur 400kV transmission lines in future monsoon seasons. This is an outcome of a change in river course approx. by 2.3 to 2.4Kms this monsoon, an act of God, for reasons completely beyond the control of DMTCL. As a result, the river is currently flowing 700m away from towers erected on open cast foundations.

While the towers on open cast foundations remain unimpacted as of now, in order to avoid any potential disruptions to power flow in future, we may consider replacing the four towers mounted on open cast piles to two tall towers on pile foundations by enhancing the span. Unless work is restricted by any new lockdowns or for other reasons beyond our control, we believe that these works can be completed before the next monsoon season. This will ensure that the Motihari LILO line remains protected and power flow remains uninterrupted if the river continues to move towards these towers.

**Members may discuss.**

**PART C: ITEMS FOR UPDATE**

**ITEM NO. C.1: ER Grid performance during November 2021**

The average and maximum consumption of Eastern Region and Max/Min Demand (MW), Energy Export for the month November-2021 were as follows:

Average Consumption (MU)	Maximum Consumption (MU)/ Date	Maximum Demand (MW) Date/Time	Minimum Demand (MW) Date/Time	Schedule Export (MU)	Actual Export (MU)
387.7	418.8 03-11-2021	21330 MW, 03-11-2021 19:23 Hrs.	12862 MW, 21-11-2021 at 14:13 Hrs.	4886	4933

Members may note.

**ITEM NO. C.2: Performance of Primary frequency response of ER generating units**

Frequency response characteristics (FRC) have been analysed pan India for one event of sudden frequency change that occurred in November 2021.

The details of this event and the overall response of the Eastern region have been summarized in following table.

Event	Frequency Change	ER FRC
<b>Event 1: On 15<sup>th</sup> November 2021 at 13:11 Hrs, 1787 MW generation loss at Bhadla in NR.</b>	<b>49.99 Hz to 49.81 Hz. Later stabilized at 49.95 Hz.</b>	43.8 %

Summary of the response of regional generating stations/SLDCs are given in following table.

Generating Station/ SLDC	Event 1
NTPC Farakka	
NTPC Kahalgaon	
NTPC Talcher	
NTPC Barh	NO Unit in service
NTPC Darlipalli	
BRBCL	
NPGC Nabinagar	
GMR	
JITPL	
MPL	
Adhunik	
Teesta V HEP	
Teesta III HEP	
Dikchu HEP	NO Unit in service

Bihar SLDC	
Jharkhand SLDC	
DVC SLDC	
GRIDCO SLDC	
WB SLDC	



Non-Satisfactory response



Response observed but non adequate



Satisfactory response

**Reason for non-satisfactory response may be explained. Detailed analysis is attached in annexure.**

**Generator end data/FRC are yet to be received from following generating stations/SLDCs**

- NPGC Nabinagar
- Bihar SLDC
- Jharkhand SLDC
- WB SLDC

**Reason for non-sharing of generator end data/FRC may be shared.**

**Members may update.**

**ITEM NO. C.3: Running Generating units at more than MCR**

As per IEGC 5.2 (h), the coal fired thermal generating station shall not resort to Valve Wide Open (VWO) operation of units whether running on full load or part load, and shall ensure that there is margin available for providing Governor action as primary response.

Generating stations failed to provide adequate primary frequency response because of running units at more than MCR and running machines with insufficient PFR margin. Same issue was highlighted and discussed during meeting held on 31st May 2021, 31st August 2021 and 28th November 2021 to evaluate the performance of primary frequency response provided by ER generating units.

As per SCADA data stored at ERLDC, injection more than 101% of MCR limit (1% margin is considered to offset SCADA measurement error) has been captured for following generating units during November 2021:

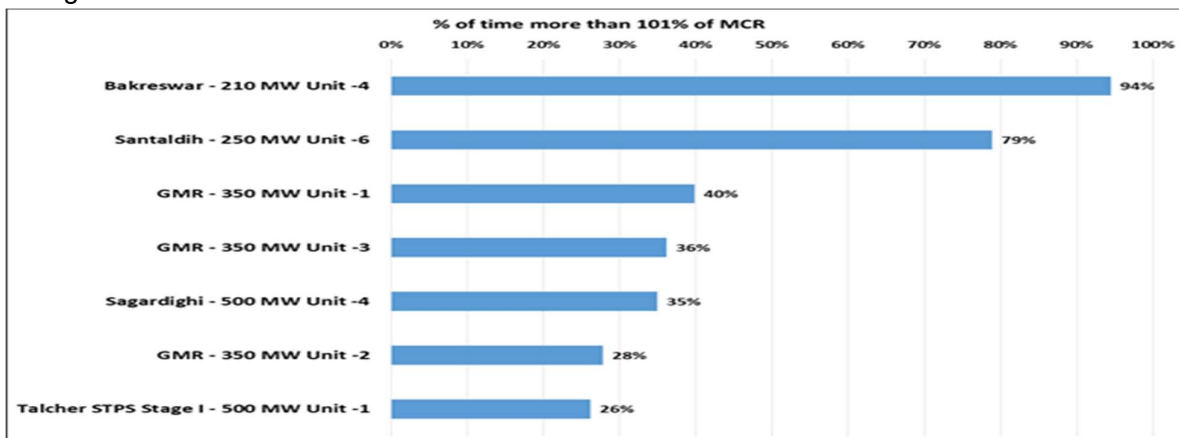

Same issue is being highlighted by ERLDC since 180th ER OCC meeting and over injection has

been observed for above generating units in spite of repeated intimation.

**WBSLDC/WBPDCL/CESC, GMR/Odisha SLDC, Talcher STPS & GMR are requested to avoid over injection more than MCR limit.**

**ITEM NO. C.4: Review of implementation of PSDF approved projects of ER.**

In 10<sup>th</sup> NPC meeting held on 09.04.2021, RPCs were advised take up the matter for improvement of the fund disbursement and expeditious implementation of the sanctioned projects under PSDF.

In view of the above, status review of the projects being executed under PSDF funding in Eastern Region would be carried out on regular basis for expediting the projects. All the constituents are requested to furnish/update the status of their respective project in every month.

Concerned utilities may update the present status of the project as given in the **Annexure-C4**.

**Members may update.**

**ITEM NO. C.5: Status of implementation of AGC as a pilot project in States.**

In 42<sup>nd</sup> TCC, DVC intimated that AGC shall be implemented in unit 7 and 8 of Mejia as per the given schedule by 31st July 2020.

WBPDCL informed that they have already collected offer from Siemens for implementation of AGC and they are awaiting the concurrence from SLDC.

SLDC, WB informed that they are not in a position to implement AGC unless a clear direction is given by WBERC. Further, implementation of intra state DSM is a prerequisite for implementation of AGC in the states.

It was decided to request CERC to include this as an issue in the Agenda for discussion in the meeting of Forum of Regulators.

OCC advised SLDC Odisha and OPGC to interact with Barh NTPC & ERLDC to get the technical specifications & the procedure for implementation of AGC.

In the 183<sup>rd</sup> OCC meeting, OPGC representative informed that work order has been issued to M/s Siemens for implementation of AGC. The work would be carried out during the unit shutdown which is scheduled from 18.10.2021.

State	Station/Unit	Deliberation in 184 <sup>th</sup> OCC Meeting
DVC	Mejia unit#7 &8	DVC representative informed that NIT is to be floated.
Odisha	Unit#3 of OPGC	OPGC vide email dated 25 <sup>th</sup> Oct'21 informed that some additional data is needed from SLDC Odisha and after getting the same AGC would be implemented.

In the 185<sup>th</sup> OCC meeting, DVC representative informed that the NIT for implementation of AGC will be floated by 9<sup>th</sup> December 2021.

OPGC representative was not present during the discussion.

**Members may update.**

**ITEM NO. C.6: Primary Frequency Response Testing of ISGS Generating Units**

In the 180<sup>th</sup> OCC meeting, ERLDC representative informed that as per communication received from GMR and JITPL PFR testing has been scheduled by Siemens in August'21.

MPL representative submitted that they would carry out the PFR testing in the month of July'21.

In the 181<sup>st</sup> OCC meeting, ERLDC representative informed that PFR testing of MPL got postponed due to some technical issue. He further informed that PFR testing is going on in APNRL and that of NPGC and BRBCL is scheduled in the last week of July'21 and 1<sup>st</sup> week of August'21 respectively.

In the 182<sup>nd</sup> OCC meeting, ERLDC representative submitted that During July – August 2021, PFR testing has been conducted at the following generating units:

1. Adhunik TPS Unit 1 & 2
2. BRBCL TPS Unit 2 & 3
3. Nabinagar STPS Unit 1
4. Kahalgaon STPS Unit 1

In the 183<sup>rd</sup> OCC meeting, ERLDC representative updated that PFR testing for Unit# 1 & 2 of GMR had been completed.

The updated status is enclosed at **Annexure-C6**.

In the 185<sup>th</sup> OCC meeting, ERLDC representative informed that PFR testing of Dikchu is being carried out.

The Committee advised all the members to provide the updated status of PFR testing, if any, to the ERPC and ERLDC.

**ITEM NO. C.7: Testing of Primary Frequency Response of State Generating units by third party agency.**

In the 171<sup>st</sup> OCC Meeting, OCC advised all the SLDC's to prepare the action plan for their state generators and submit the details to ERPC and ERLDC at the earliest.

DVC vide-mail dated 6<sup>th</sup> Oct 2020 informed that the Primary Frequency Response Testing may be carried out for the following generating units:

Sl. No.	Name of the Units	Capacity (MW)
1	BTPS-A	500
2	CTPS Unit #7&8	2X250
3	DSTPS Unit#1&2	2X500
4	KTPS Unit # 1&2	2X500

5	MTPS Unit # 3 to 8	2 X 210 +2 X 250 + 2X 500
6	RTPS Unit # 1 & 2	2 X 600

In the 182<sup>nd</sup> OCC meeting, WBPDCCL representative submitted that they had taken the budgetary offer form Siemens and Solvina and the same is in process for administrative approval. PO would be issued to the selected party after getting the necessary approval.

Jharkhand representative submitted that no update has been obtained from Tenughat in this regard.

DVC representative submitted that the Indent for this work had been placed in April'21 and they are in the process for floating the NIT.OHPC representative submitted that the order would be issued to M/s Solvina by 1<sup>st</sup> week of September'2021.

In the 183<sup>rd</sup> OCC meeting, OHPC representative submitted that work order has been placed on M/s Slovenia and they are planning to conduct the test in the month of Nov'21 for unit#5 of Rengali& Unit #4 of Indravati HEP.

TVNL representative submitted that due to coal shortage issue, the PFR testing of Unit #1 could not be planned. The same would be taken up once the coal supply gets improved.

WBPDCCL representative submitted that they are yet to receive the administrative approval. The work order would be placed after getting the approval.

In the 184<sup>th</sup> OCC meeting, OHPC representative submitted that the order has been placed to M/s Solvina on 3<sup>rd</sup> Sept'21 and the testing of unit#5 of Rengali & Unit #4 of Indravati HEP are scheduled to be conducted in the month of Nov'21.

TVNL representative was not available in the meeting.

WBPDCCL representative submitted that the tender has been floated and the bid opening is scheduled in the 1<sup>st</sup> week of Nov'21. He further informed that the order would be placed by 3<sup>rd</sup> week of November'21.

In the 185<sup>th</sup> OCC meeting, OHPC representative informed that testing of Primary Frequency Response of all the units of Rengali and Indravati will be done by the end of December 2021.

WBPDCCL representative informed that they will place the order in the month of December 2021.

**Members may update.**

**ITEM NO. C.8: PSS tuning of Generators in Eastern Region.**

The PSS tuning activity is mandatory in line with IEGC and CEA regulations. The Procedure of PSS tuning for helping utilities in getting this activity carried out has been approved in 171<sup>st</sup> OCC Meeting and shared with all concerned utilities.

CESC representative submitted that PSS tuning for Budge Budge unit#1 & 2 was done on 16<sup>th</sup>



& 17<sup>th</sup> Aug'21 respectively.

ERLDC representative informed that PSS tuning for Mejia unit#4, Mangdechhu unit#3 & 4, DPL unit#7 and Kahalgaon unit#2 was done satisfactorily. However, PSS tuning for APNRL was not successful.

DGPC Bhutan representative submitted that for Chuka, Tala and Mangdechhu they had shared their report to ERPC.

In the 183<sup>rd</sup> OCC meeting, DVC representative informed that for PSS tuning for Unit#1 of Koderma TPS was carried out on 07/09/2021.

OCC advised DVC to submit the test report to ERLDC/ERPC.

In the 184<sup>th</sup> OCC meeting, ERLDC representative submitted that PSS tuning for Teesta-III is scheduled on 17<sup>th</sup> Nov'21. However, update from Bhutan is still pending.

OHPC representative mentioned that PSS tuning for all the units of Rengali was carried out from 10<sup>th</sup> to 13<sup>th</sup> Oct'21 and was tuned properly. He further added that the report would be shared to ERPC and ERLDC.

The updated schedule for PSS tuning of the units is attached at **Annexure-C8**.

In the 185<sup>th</sup> OCC meeting, ERLDC informed the forum that PSS Tuning of Teesta-V was conducted but was not successful. Further, it was also informed that Rongnichu and Chuzachen are also going to carry out the PSS Tuning.

**Members may update.**

**ITEM NO. C.9: Status of UFRs healthiness installed in Eastern Region.**

**Members may update** the status of UFR healthiness installed in Eastern Region.

**ITEM NO. C.10: Status of Islanding Schemes healthiness installed in Eastern Region.**

As per the decision taken in the meeting held on 8<sup>th</sup> July 2021 and chaired by member (GO&D), CEA, data in prescribed formats may be submitted by concerned utilities to RPCs on monthly basis to certify the healthiness of the Islanding Schemes.

**a. Format - I for RLDC/SLDCs**

S.NO	Name of Islanding Scheme	Healthiness of Communication channel

**b. Format - II for Generating Station**

S.NO	Name of Islanding Scheme	Healthiness of Islanding Relay	Healthiness of Communication channel

**c. Format - III for Transmission Utility/DISCOMs**

S.NO	Name of Islanding Scheme	Elements considered for tripping to from Island	For communication-based tripping logic Of feeders	For UFR based tripping logic of feeders	
			Healthiness of Communication channel	Healthiness of PT Fuse and status of DC supply to UFR relay*	Healthiness of Relay#

\* Where dedicated UFR relay have been installed for tripping of the feeders under Islanding scheme

# Where UFR functions have been enabled within backup protection relay of the line.

**d. Format - IV for collecting Relay details of the Islanding scheme.**

The following format may be used to get Relay details of the Islanding scheme:

S.NO	Description	UFRs-for load relief (A)	df/dt -for load relief (B)	Relay for Island creation(C)
1	Relay location (S/s name)			
2	Relay make & model			
3	Frequency setting of the relay (at which load shedding is envisaged)			
4	Feeder name (voltage level and source-destination name) signaled by the Islanding Relay for separation /load shedding/separation from outside grid			
5	Quantum of load relief due to tripping of feeder (as per state's peak of previous year)			
6	Quantum of load (Min, Avg, Max in MW) on the feeder (as perstate's peak of previous year)			

**e. Format - V for Contact details of all Nodal Officers**

Utility Name & Location	Name	Designation	Organization	Email ID	Mobile No.

It was deliberated in the 185<sup>th</sup> OCC meeting that except West Bengal all the entities are sending the report as per the new format.

Members may update.

**ITEM NO. C.11: Transfer capability determination by the states.**

**Latest status of State ATC/TTC declared by states during the month of January-2022**

SI No	State/Utility	TTC (MW)		RM(MW)		ATC Import (MW)		Remark
		Import	Export	Import	Export	Import	Export	
1	BSPTCL	5150	--	103	--	5047	--	Jan-22
2	JUSNL	1551	--	47	--	1504	--	Jan-22
3	DVC	1594	2840	63	50	1531	2790	Jan-22
4	OPTCL	2360	1090	104	58	2256	1032	Jan-22
5	WBSETCL	5841	--	4501	--	5031	--	Jan-22
6	Sikkim	--	--	--	--	--	--	Jan-22

As per the agreed philosophy the status of month wise ATC/TTC submission is as follows:

State	Bihar	Jharkhand	DVC	Odisha	West Bengal	Sikkim
<b>Month</b>						
<b>Dec-21</b>	Submitted	Submitted	Submitted	Submitted	Submitted	Pending
<b>Jan-22</b>	Submitted	Submitted	Submitted	Submitted	Submitted	Pending
<b>Feb-22</b>	Submitted	Submitted	Submitted	Pending	Submitted	Pending
<b>Mar-22</b>	Submitted	Submitted	Submitted	Pending	Pending	Pending
<b>Apr-22</b>	Pending	Pending	Submitted	Pending	Pending	Pending

**Declaration of TTC/ATC on SLDC Website:**

SI. No	SLDC	Declared on Website	Website Link	Constraint Available on Website	Type of Website Link
1	BSPTCL	Yes	<a href="http://www.bsptcl.in/ViewATCTTCWeb.aspx?GL=12&amp;PL=10">http://www.bsptcl.in/ViewATCTTCWeb.aspx?GL=12&amp;PL=10</a>	Yes	Static Link-Table
2	JUSNL	Yes	<a href="http://www.jusnl.in/pdf/download/ttc_atc_nov_2020.pdf">http://www.jusnl.in/pdf/download/ttc_atc_nov_2020.pdf</a>	Yes	Static link –pdf file
3	DVC	Yes	<a href="https://application.dvc.gov.in/CLD/atctcmenu.jsp#">https://application.dvc.gov.in/CLD/atctcmenu.jsp#</a>	Yes	Static Link-Word file

4	OPTCL	Yes	<a href="https://www.sldcorissa.org.in/TTC_ATC.aspx">https://www.sldcorissa.org.in/TTC_ATC.aspx</a>	Yes	Static Link-pdf file
5	WBSETCL	Yes	<a href="http://www.wbsldc.in/atc-ttc">http://www.wbsldc.in/atc-ttc</a>	No (Not updating)	Static Link-Table
6	Sikkim	No	<a href="https://power.sikkim.gov.in/atc-and-ttc">https://power.sikkim.gov.in/atc-and-ttc</a>	No (Not updating)	Static Link-Excel file

It is necessary to highlight that the ATC/TTC declaration on website need to be updated in timely manner. It is suggested that along with PDF copies, a tabular format may also kindly be provided so that it can be utilized for preparing ERLDC portal on State ATC/TTC. In addition, ATC/TTC may be declared three months in advance and periodically reviewed based on any shutdown causing leading to any constraint.

**Members may update.**

**ITEM NO. C.12: Mock Black start exercises in Eastern Region**

Mock black start date for financial year 2021-22 is as follows:

Sl. No	Name of Hydro Station	Schedule	Tentative Date	Schedule	Tentative Date
		Test-I		Test-II	
1	U. Kolab	Last week of Oct 2021		Second Week of Feb 2022	
2	Balimela	Second week of Nov 2021		First Week of March 2022	
3	Rengali	Second week of Nov 2021		First 2eek of March 2022	
4	Burla	Second week of Nov 2021		First Week of March 2022	
5	U. Indravati	Last week of Oct 2021		Second Week of Feb 2022	
6	Maithon	Third Week of Nov 2021		First Week of March 2022	
7	TLDP-III	Second week of Nov 2021		Second Week of Feb 2022	
8	TLDP-IV	Third Week of Nov 2021		First Week of March 2022	
9	Subarnarekha	Second week of Nov 2021		Second Week of Feb 2022	
10	Teesta-V	Third Week of Nov 2020		Third Week of March 2022	
11	Chuzachen	Done on 9 <sup>th</sup> April'21		First Week of March 2022	
12	Teesta-III	Third Week of Nov 2021		First Week of March 2022	
13	Jorethang	Third Week of Nov 2021		First Week of March 2022	

14	Tasheding	Second week of Nov 2021		First Week of March 2022
15	Dikchu	Second week of Nov 2021		Second Week of Feb 2022

SLDC, Odisha representative informed that they would go for Mock Black Start of Balimela in the 2<sup>nd</sup> week of August '21.

In the 182<sup>nd</sup> OCC meeting, OHPC representative submitted that Mock Black Start had been done for Rangali on 18<sup>th</sup> August'21 and they would go for Mock Black Start of Balimela in Sept'21.

OCC advised the concerned utilities to give prior intimation to ERLDC and ERPC regarding Mock Black Start.

In the 183<sup>rd</sup> OCC meeting, SLDC Odisha representative informed that mock black start for Balimela has been scheduled in Nov-21.

Teesta III HEP representative submitted that mock black would be carried out for their plant in Nov'21 as per the schedule.

In the 185<sup>th</sup> OCC meeting, SLDC Odisha representative was not present in the discussion.

JUSNL vide letter dated 25.11.2021 informed that the Mock Black Start exercise at Subarnarekha Hydrel Power, Sikidiri is scheduled on 03.12.2021 (Friday) from 11:00 hrs. to 13:00 hrs.

**Members may update.**

**ITEM NO. C.13: Mock Black Start Exercise of Teesta-V**

All Eligible plants are required to carry out mock black start exercises twice every year. At present most of the HEPs connected at ISTS are mock black starting the units and

synchronizing it at the next substation without running it with some nearby substations load. Therefore, for checking the machine governing capability it is desirable to perform the mock black start with some load.

As per information received from Teesta V, the following are the load requirements for running units stably

- Minimum load: 10 MW
- Maximum load before entering into the forbidden zone of operation: 40 MW

To facilitate this mock black start exercise two schemes are proposed one taking the load of NJP (West Bengal).

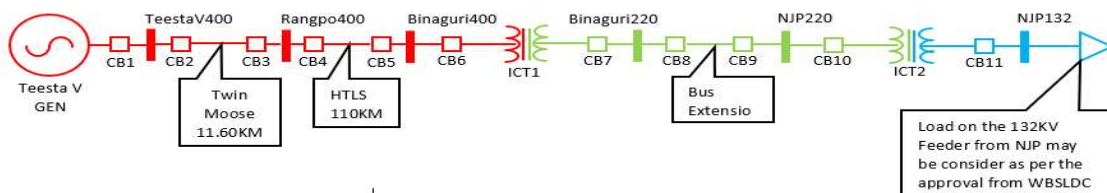

And other by taking the load of Melli (Sikkim)

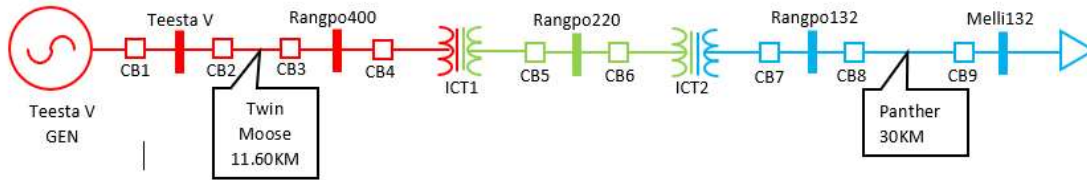

**Keeping in view the importance of black start WBSLDC and Sikkim SLDC are requested to identify distribution feeders which can be utilized for carrying out the black start exercise.**

**ITEM NO. C.14: Updation of Black Start and Restoration procedure of Eastern Region**

As per clause IEGC 5.8(a)

“Detailed plans and procedures for restoration of the regional grid under partial/total blackout shall be developed by RLDC in consultation with NLDC, all Users, STU,SLDC, CTU and RPC Secretariat and shall be reviewed / updated annually..”

The restoration procedure of Eastern Region was last updated in the month of Jan-2021 and same can be accessed through following link

[https://app.erldc.in/Content/Upload/System%20Study/System\\_Reliability%20report/ER%20Restoration%20procedure%20Jan%202021.pdf](https://app.erldc.in/Content/Upload/System%20Study/System_Reliability%20report/ER%20Restoration%20procedure%20Jan%202021.pdf)

ERLDC is in the process of updating Black Start and Restoration Procedure for Year 2022. All utilities are requested to go through the last updated restoration procedure and provide the input for changes if any. Further all the SLDCs are requested to share updated restoration procedure of their respective state so that information from same can be appropriately included in Eastern Regional Restoration Procedure.

**Members may note.**

**ITEM NO. C.15: Furnishing readiness of generators before lighting up of units.**

In case any ISGS unit is under shutdown/outage the concerned generator need to inform ERLDC (for onward dissemination of information to beneficiaries) once it is ready to be brought back to bar. The unit light up is to be done after getting intimation from beneficiaries (through ERLDC) regarding requirement of power for the said unit.

**Members may note.**

## PART D: OPERATIONAL PLANNING

### ITEM NO. D.1: Anticipated power supply position during January 2022

The abstract of peak demand (MW) vis-à-vis availability and energy requirement vis-à-vis availability (MU) for the month of January 2022 were prepared by ERPC Secretariat on the basis of LGBR for 2021-22 and feedback of constituents, keeping in view that the units are available for generation and expected load growth etc. is enclosed at **Annexure D1**.

**Members may update.**

### ITEM NO. D.2: Shutdown proposal of generating units for the month of January 2022

Generator unit shutdown schedule for January' 2022 is given in the table:

<b>Proposed Maintenance Schedule of Thermal Generating Units of ER during 2021-22 in the month of January'2022</b>								
System	Station	Unit No.	Capacity (MW)	Period (As per LGBR 2021-22)		No. of Days	Reason	Remarks
				From	To			
WBPDC L	Kolaghat TPS	3	210	15.01.2022	24.01.2022	10	PG Test	
	Bandel TPS	2	60	05.01.2022	14.01.2022	10	PG Test	
	Sagardighi TPS	3	500	21.01.2022	14.02.2022	25	AOH+BOH	
CESC	Titagarh TPS	1	60	02.01.2022	05.01.2022	4		
	Titagarh TPS	2	60	07.01.2022	21.01.2022	15		
CESC/HEL	HEL	1	300	03.01.2022	16.02.2022	45	COH	

**Members may discuss.**

### ITEM NO. D.3: Shutdown proposal of Transmission lines/equipment.

#### **D3.1 Shutdown of 400 kV Bus-1 &2 at Rangpo S/s**

The following shutdown schedule was proposed by Powergrid for GD wiring modification work at Rangpo S/s. During discussion in 186th OCC Outage Coordination meeting, it was informed that during the proposed shutdown, unit shutdown is required for of hydro generators in Sikkim which are connected to Rangpo S/s at 400 kV as well as 220 kV level. Considering the issues raised by Tashiding & Rangpo on the shutdown of 220 kV buses at Rangpo & spillage of water during the unit outage, it was decided to discuss the proposed shutdown in the forthcoming OCC meeting.

Element	Type	D/C	Reason	From Date	From Time	To Date	To Time
400KV MAIN	BUS	D	For GD wiring	04-Jan-	08:00	05-Jan-	17:00



BUS - 1 AT RANGPO			modification work	2022		2022	
400KV MAIN BUS - 2 AT RANGPO	BUS	D	For GD wiring modification work	04-Jan-2022	08:00	05-Jan-2022	17:00

Members may discuss.

**ITEM NO. D.4: Major Generating Units/Transmission Element outages/shutdown in ER Grid (as on 13.12.2021)**

a) Thermal Generating Stations outage report:

SL No	STATION	STATE	AGENCY	UNIT NO	CAPACITY (MW)	REASON(S)	OUTAGE DATE
1	KOLAGHAT	WEST BENGAL	WBPD CL	1	210	Initially taken under ESPR&M work. Presently under consideration for de-commissioning.	07-Jun-2018
2	BARAUNI TPS	BIHAR	BSPHCL	6	110	Abnormal TSI parameter	17-Mar-2021
3	KOLAGHAT	WEST BENGAL	WBPD CL	2	210	Initially taken under ESP& ash handling R&M work. Presently under consideration for de-commissioning.	26-Jun-2021
4	MUZAFFAR PUR TPS	BIHAR	BSPHCL	1	110	Completion of tenure of PPA	08-Sep-2021
5	MUZAFFAR PUR TPS	BIHAR	BSPHCL	2	110	Completion of tenure of PPA	08-Sep-2021
6	WARIA TPS	DVC	DVC	4	210	Condenser tube leakage	15-Oct-2021
7	BAKRESHWAR	WEST BENGAL	WBPD CL	2	210	Planned maintenance	09-Nov-2021
8	BOKARO-A'	DVC	DVC	1	500	Annual overhauling	10-Nov-2021
9	KHSTPP	BIHAR	NTPC	4	210	Annual overhauling	16-Nov-2021
10	DARLIPALI	ODISHA	NTPC	1	800	Annual overhauling	25-Nov-2021
11	TENUGHAT	JHARKHAND	TVNL	1	210	Boiler Tube Leakage and coal shortage	03-Dec-2021
12	TSTPP	ODISHA	NTPC	1	500	Annual overhauling	04-Dec-2021
13	Sterlite	ODISHA	SEL	3	600	Ash handling problem	08-Dec-2021
14	OPGC	ODISHA	OPGC	4	660	Due to 30% feed water line upstream	11-Dec-2021

						MOV heavy gland leakage	
15	KOLAGHAT	WEST BENGAL	WBPD CL	6	210	Due to drum level very high. Now machine is in box up condition due to empty bunker.	12-Dec-2021

All Generating stations are requested to update expected restoration time and reason outage to ERLDC/ERPC on weekly basis in case of any change at their end.

**b) Major Generating stations Out on Reserve Shutdown due to low system demand:**

S. NO	STATION	STATE	AGENCY	UNIT NO	CAPACITY (MW)	REASON(S)	OUTAGE DATE
1	BARAUNI TPS	BIHAR	BSPHCL	7	110	RSD/ LOW SYSTEM DEMAND	29-Oct-2021
2	MEJIA TPS	DVC	DVC	2	210	RSD/ LOW SYSTEM DEMAND	25-Nov-2021

**c) Hydro Unit Outage Report:**

S. NO	STATION	STATE	AGENCY	UNIT NO	CAPACITY (MW)	REASON(S)	OUTAGE DATE
1	BALIMELA HPS	ODISHA	OHPC	1	60	R & M WORK	05-Aug-2016
2	BALIMELA HPS	ODISHA	OHPC	2	60	R & M WORK	20-Nov-2017
3	BURLA HPS/HIRAKUDI	ODISHA	OHPC	5	37.5	R & M WORK	25-Oct-2016
4	RENGALI HPS	ODISHA	OHPC	3	50	DUE TO HEAVY OIL LEAKAGE FROM SUMP TAK	19-Jul-2021

It is seen that about 207.5 MW hydro capacities in Odisha is under forced outage / planned outage and therefore not available for providing the much-needed peaking support during evening peak.

SLDC / OHPC may please indicate restoration plan of the units.

**d) Long outage report of transmission lines:**

SL. NO	TRANSMISSION ELEMENT / ICT	AGENCY	OUTAGE DATE	REASONS FOR OUTAGE
1	400 KV IBEUL JHARSUGUDA D/C	IBEUL	29.04.2018	TOWER COLLAPSE AT LOC 44,45

2	220/132 KV 100 MVA ICT II AT LALMATIA	FSTPP/JUSNL	22.01.2019	FAILURE OF HV SIDE BREAKER
3	220 KV PANDIABILI - SAMANGARA D/C	OPTCL	03.05.2019	49 NOS OF TOWER COLLAPSED.AS REPORTED BY SLDC OPTCL, TOTAL 60 NOS OF TOWER IN BETWEEN 220KV PANDIABILI – SAMANGARA LINE IN WHICH 48 NOS TOWERS FULLY DAMAGED AND 12 NOS TOWERS PARTIALLY DAMAGED. WORK UNDER PROGRESS.PRESENTLY CHARGED FROM PANDIABILLI END (LOC 156) TO LOC 58
4	220KV BARAUNI-HAJIPUR CKT-1	BSPTCL	28.09.2019	TOWER COLLAPSE AT LOCATION 38 & 39. CKT-2 IS ON ERS SINCE 13.01.2020.
5	220/132 KV 100 MVA ICT 3 AT CHANDIL	JUSNL	30.04.2020	ICT BURST AND DAMAGED AFTER FIRE REPORTED
6	220KV/132 KV 100 MVA ICT 4 AT RANGPO	PGCIL	08.04.2021	Hand Tripped after tripping of all 400/220 icts at rangpo on 8.4.21 after disturbance and thereafter developed relay reset problem. Not commisioned.
7	400KV/220KV 315 MVA ICT 2 AT MEERAMUNDALI	OPTCL	21.02.2021	FIRE HAZARD
8	400KV/220KV 315 MVA ICT 4 AT JEERAT	WBSETCL	09.04.2021	Verbally confirmed by WB that new Transfromer procurement under pipeline and shall be replaced in the near future.
9	220KV-FSTPP-LALMATIA	JUSNL	21.04.2021	THREE TOWER COLLAPSED NEAR LALMATIA

Transmission licensees/ Utilities are requested to update expected restoration date & work progress regarding restoration regularly to ERLDC/ERPC on monthly basis by 5th of each month so that status of restoration can be reviewed in OCC. Utilities are also requested to update outage of any elements within their substation premises like isolator/breaker to ERLDC/ERPC regularly. (Reported as per Clause 5.2(e) of IEGC).

**Members may update.**

**ITEM NO. D.5: Commissioning of new units and transmission elements in Eastern Grid in the month of November-2021**

The details of new units/transmission elements commissioned in the month of November-2021 based on the inputs received from beneficiaries:

SL. No	Agency/ Owner	Element Name	Date	Time	Remarks
1	NKTL	220KV MAIN BAY OF GOVINDPUR -1 AT DHANBAD (NKTL)	16-Nov-21	16:25	
2	NKTL	220KV MAIN BAY OF GOVINDPUR -2 AT DHANBAD (NKTL)	16-Nov-21	16:30	
3	NKTL	220KV MAIN BAY OF JAINAMORE -2 AT DHANBAD (NKTL)	16-Nov-21	16:02	
4	NKTL	220KV MAIN BAY OF JAINAMORE -1 AT DHANBAD (NKTL)	16-Nov-21	16:07	

Members may update.

**ITEM NO. D.6: UFR operation during the month of November 2021**

Frequency profile for the month as follows:

Month	Max	Min	Less IEGC Band (%)	Within IEGC Band (%)	More IEGC Band (%)
	(Date/Time)	(Date/Time)			
Nov, 2021	50.27 Hz on 28.11.2021 at 06:01 Hrs.	49.63 Hz on 08.11.2021 at 06:54 Hrs.	08.02	74.09	17.89

Hence, no report of operation of UFR has been received from any of the constituents.

Members may note.

\*\*\*\*\*

## Islanding Performance and Observations During Past Islanding of CESC

Islanding Performance and Frequency variation for past few Islanding events were checked for Island stability evaluation and following observations are listed in regard to this, (Plots for each event in attached)

- Oscillating Variation of frequency after island formation in Budge-budge frequency is observed upto (0.5-1Hz) and was varying continuously till it got synchronised with grid at Howrah point, this may also be checked.
- Such prolonged variation of frequency during whole islanded mode may be checked.
- In event 3 Budge-Budge Unit generation was also oscillating, root cause for which needs to be looked into which is ultimately driving the frequency of island.(Plot attached)
- Any cyclic load changes or other behaviour may also be analysed. Variation of traction and Metro load may also be studied.
- **Governor parameter tuning during islanded mode may also be checked along with PSS for stability during islanded mode.**
- **Reason for such continuous high oscillating variation in frequency may be analysed and possible consequences may also be looked.**
- **Frequency of oscillation was very slow 1 cycle in a minute so approx. 0.014Hz. So mechanical parameters associated with Machines may be checked for root cause analysis .**
- **Under frequency load shedding setting as shared within the island starts from 49.4Hz and may cause operation of UFR relay in some cases inside the island. Which is detrimental for island survival.**
- **As observed in below cases for 2 events, Frequency dipped upto 49.5 & 49.6Hz due to these variations. Chakmir -47Mw is under UFR shedding at 49.4Hz, tripping of which may further cause stability problem within island. (Setting attached)**
- **Same variation pattern was also observed during past events also one such event of 28April 2020 was checked and same observation found (Plot attached).**

**SCADA plot for EVENT 1: 01<sup>st</sup> August 18:18Hrs, Budge-Budge generation Vs CESC frequency vs Grid Frequency**

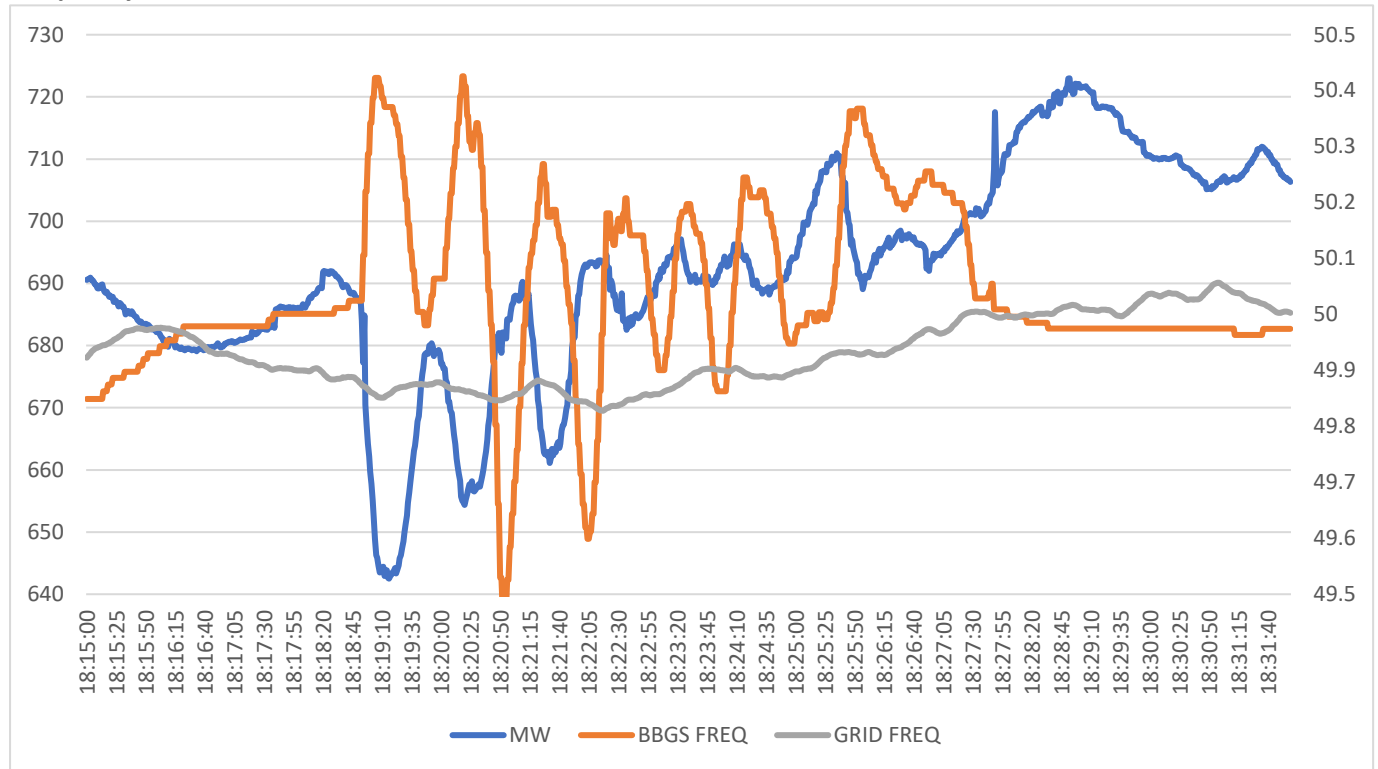

**SCADA plot for EVENT 2: 01<sup>st</sup> August 19:50 Hrs ,BugBug generation Vs CESC frequency vs Grid Frequency**

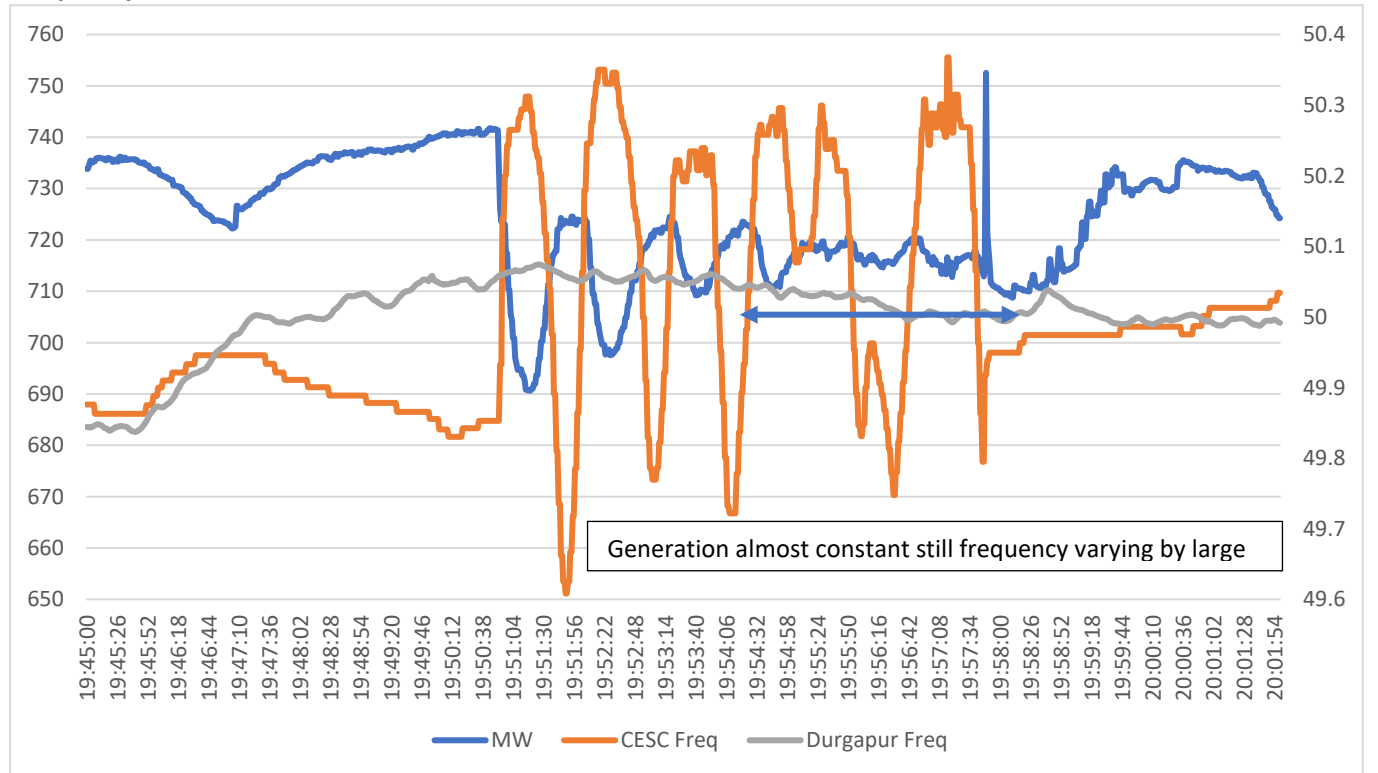

**EVENT 3: Variation on 15<sup>th</sup> September Islanding: SCADA plot with 2 second resolution**

Same pattern of Frequency variation observed. Governor performance during Islanding needs to be checked. In 15th September event also Budge-budge generation is oscillatory this needs to be checked and also any cyclic load variation for the same to be looked.

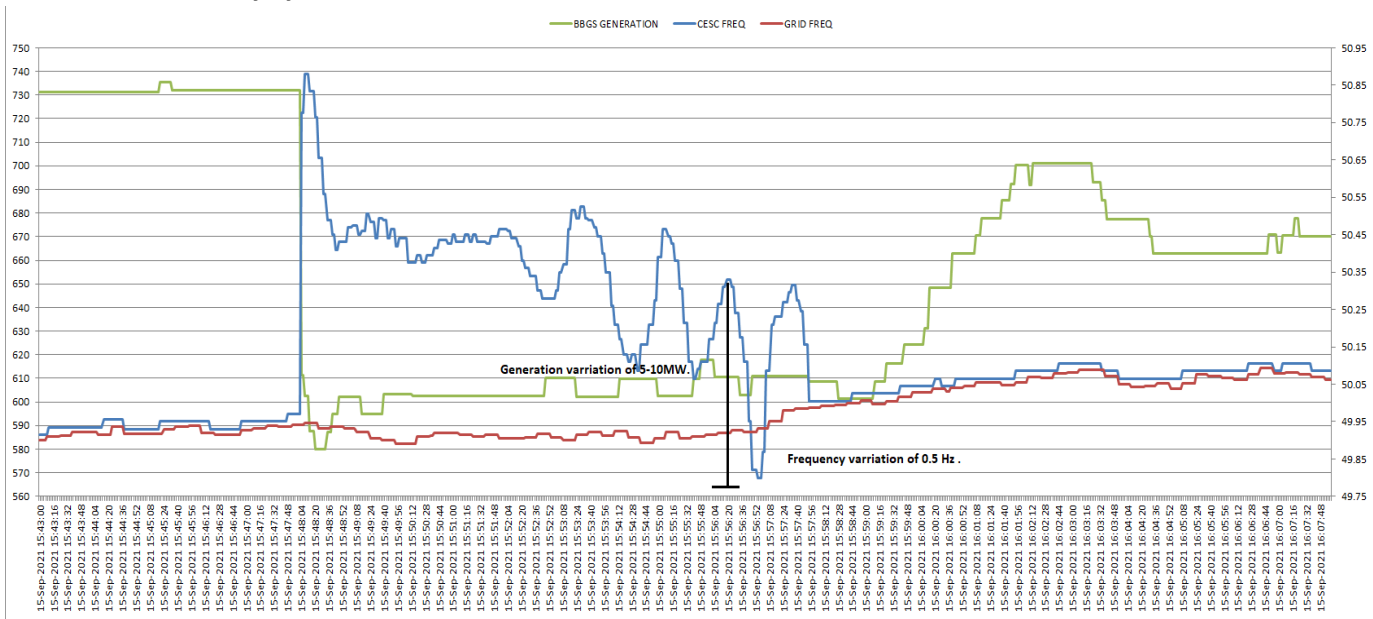

**EVENT 4 :PAST ISLANDING ON 28 APRIL 2020:**

In the 2020 Event also same very low frequency oscillatory variation observed

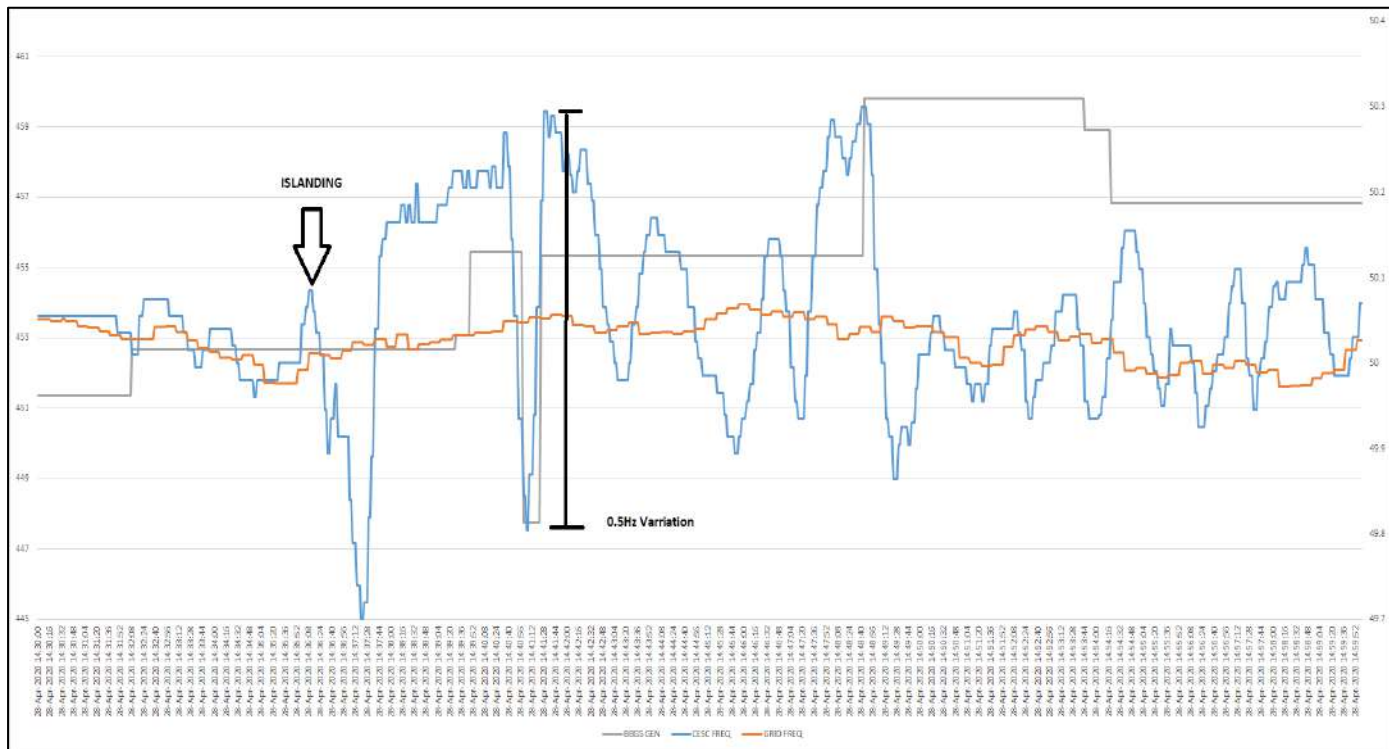



**Oscillation Frequency as observed from FFT Spectrum: Very low frequency of 0.014 Hz observed**

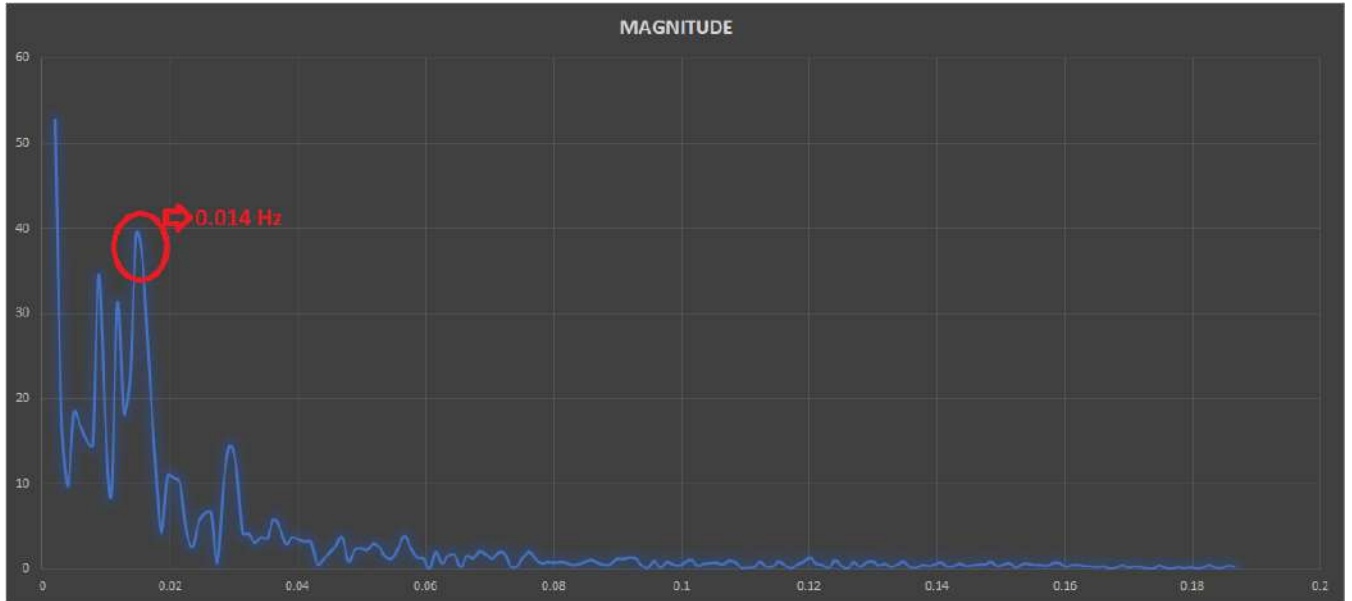

**UFR setting for First Two stages:**

Settings of Under frequency relays				
CESC system				
Stage	132/33kV G/S/S	33kV Feeder	Max Load in MW	
Stage-I			SUMMER	WINTER
49.4Hz	CHAKMIR	55 MVA TRF - 1 & 2	47	29
	NCGS	KAMARHATI TRF - 1	8	6
		KUTIGHAT TRF - 3	10	8
TOTAL			<b>65</b>	<b>43</b>
Stage-II				
49.2Hz	DUMDUM	NEW DUMDUM TRF - 1	15	11
		NEW DUMDUM TRF - 2	14	9
		SOUTH DUMDUM TRF - 1	15	8
		DUMDUM TRF - 3	12	7
	BBGS	BAURIA 1 & 3	18	12
		FORESHORE RD D/S( 6 KV FEEDER)	9	5
		SALIMAR D/S ( 6 KV FEEDER)	7	3
TOTAL			<b>90</b>	<b>55</b>

# VERIFICATION BY PMU PLOTS FOR ALL EVENTS

## EVENT 1: Frequency comparison by PMU Plot:

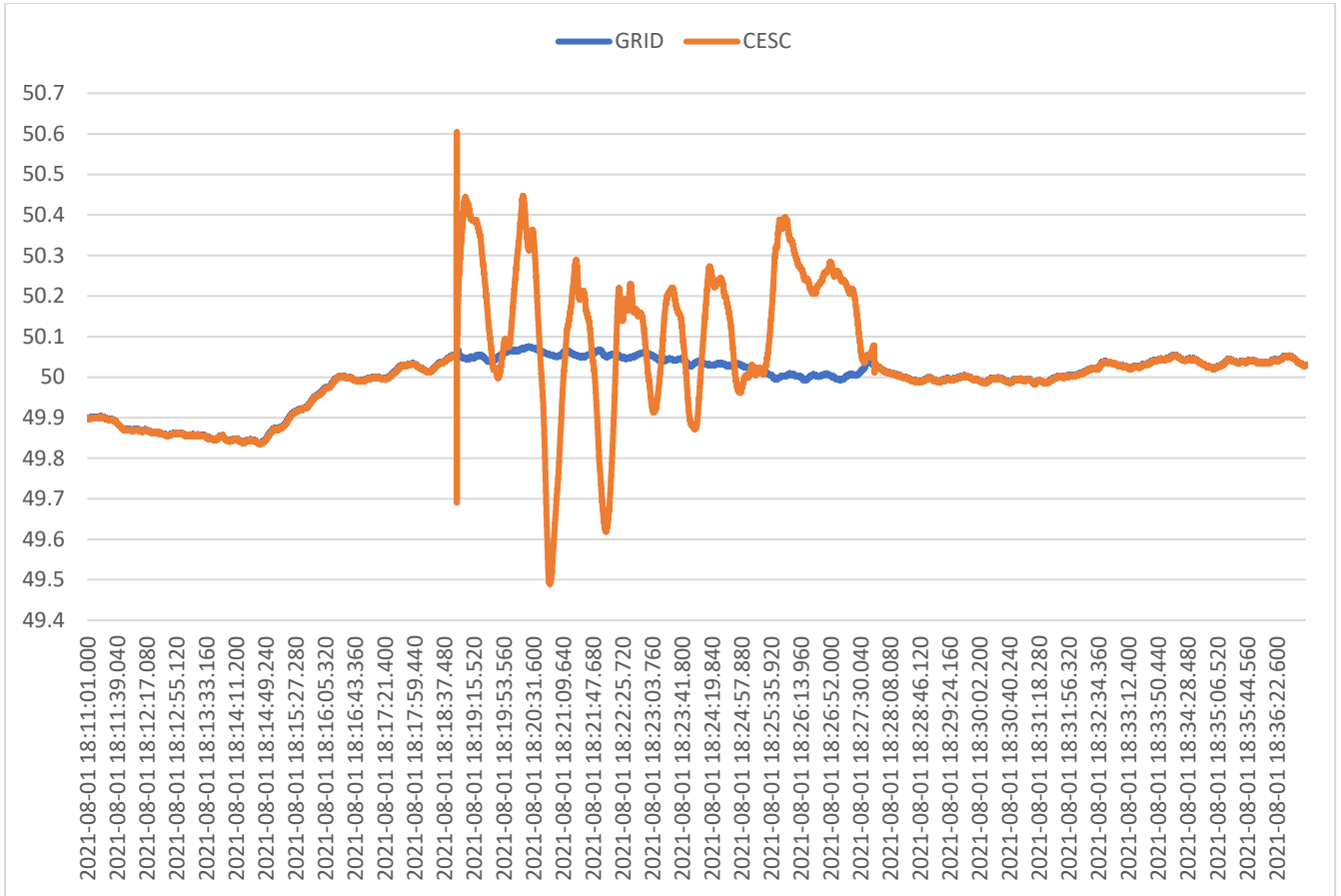

## EVENT 2 Frequency comparison by PMU Plot:

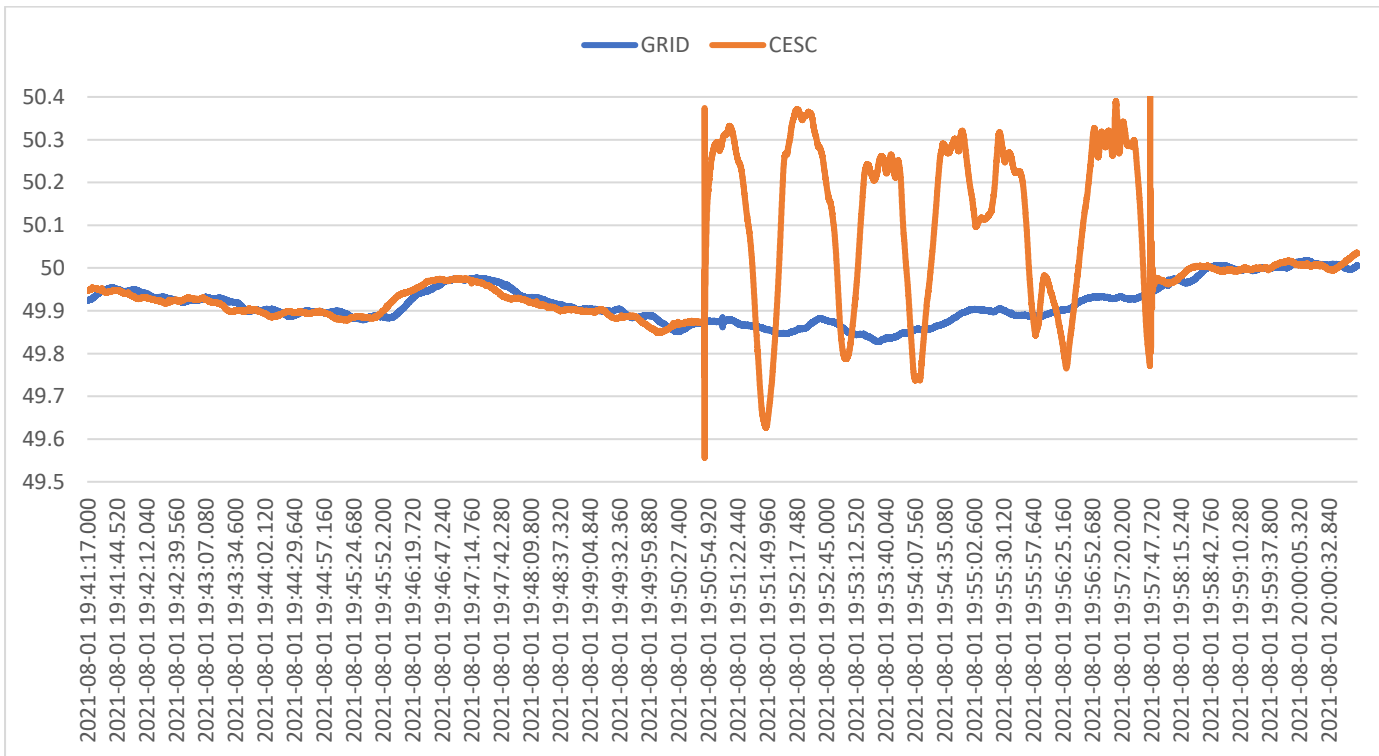

### EVENT 3: PMU PLOT 15 September 2021

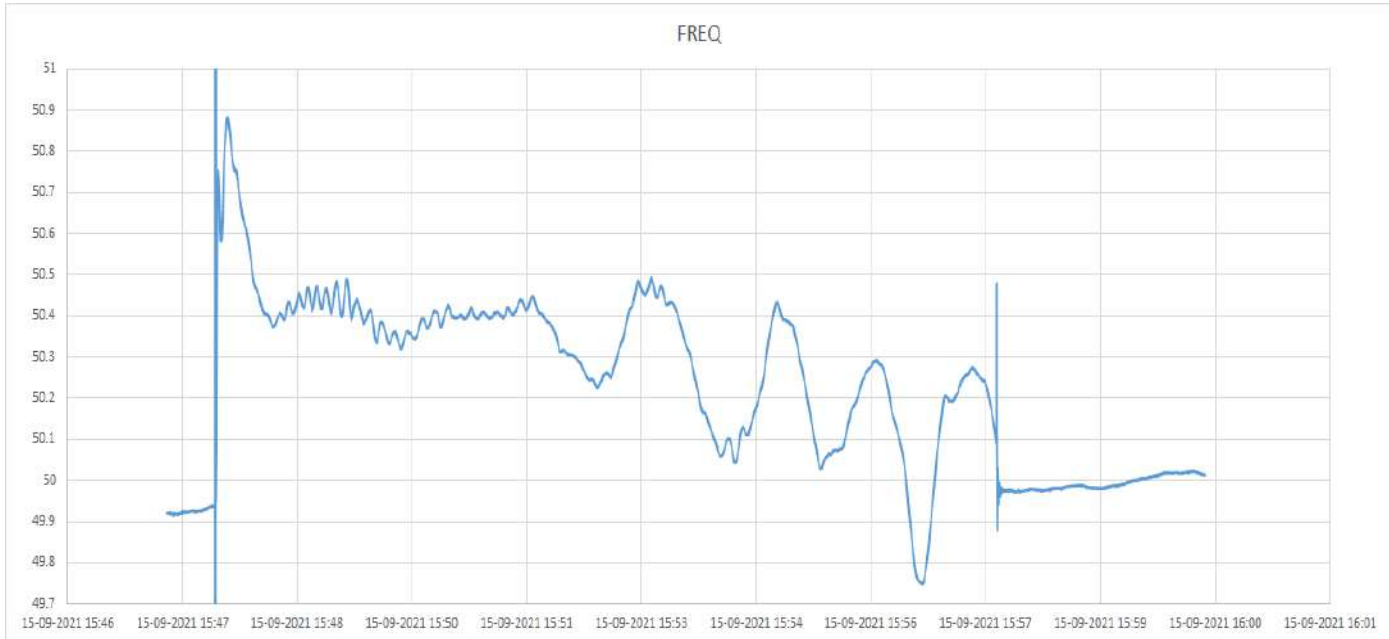

**MOM Held at ERLDC on 30.11.2021 between Officials of ERLDC & CESC regarding  
Agenda Item No. B. 8 of 185<sup>th</sup> OCC Meeting on 23.11.2021**

**Members Present:**

ERLDC	CESC
Mr Gopal Mitra	Mr Snehasis Samaddar
Mr Rajib Sutradhar	Mr Sibir Roy
Mr Amaresh Mallick	Mr Arunava Sen Gupta
Mr Shyamal Konar	Mr Susovan Narayan Choudhury
Mr Saugato Mondal	Mr Arghya Ghosal
Mr Saurav Kr. Sahay	
Mr Chandan Kumar	
Mr Raj Protim Kundu	
Mr Alok Pratap Singh	
Mr Saibal Ghosh	

**UEL and PSS**

1. A holistic study will be carried out by CESC regarding PSS and UEL of BBGS - Will start from January, 2022 and will take 2-3 months.
2. Network for Synchronization of CESC System at 220 KV with Kasba S/S of WBSETCL is expected to be ready by March, 2022.
3. PSS and UEL performance of BBGS will be checked and tuning parameters will be validated post synchronization at Kasba 220 KV. In case of any delay in Synchronization of CESC System at 220 KV with Kasba S/S, revised timeline for field testing of PSS and UEL may be decided after discussion in appropriate forum.

**Islanding Operation**

1. PFR testing of BBGS Units will be carried out in February, 2022.
2. 'Islanded' signal will be incorporated in BBGS Unit 3 DCS for RGMO - FGMO switchover and performance will be checked. This trial will be given after PFR testing.

**ERLDC Request**

1. Study regarding PSS and UEL of BBGS needs to be done considering connectivity at 220 kV level as well 132 kV level separately in view of operating scenario during any contingency – CESC will revert.
2. Study needs to be done to ascertain whether 150 ms time delay in Islanding Scheme of CESC can be increased post Synchronisation at Kasba 220 KV, considering the Critical Clearing Time of BBGS Units – Study will be done by CESC.
3. A single combined 'Load of CESC's Islanded System' (from Substations level) to be calculated and made available to ERLDC for enabling them to display in their SCADA – Feasibility will be checked by CESC.
4. Direct access to PMU at BBGS and EMSS to be provided to ERLDC for monitoring and analysis of islanding condition – Feasibility will be checked by CESC.

## LOW FREQUENCY OSCILLATION BETWEEN 03:52 TO 03:58 Hrs ON 20/09/2021

LFO of **0.8-0.9 Hz** was observed between 03:53 Hrs to 03:57 Hrs near Subhasgram area, magnitude of which was observed most near Subhas gram and magnitude started reducing as moving away from Subhasgram.

It was most prominent in Frequency only.

**LFO was of Local mode which indicates that the oscillation initiated with hunting of any nearby unit.**

### Subhas gram Frequency

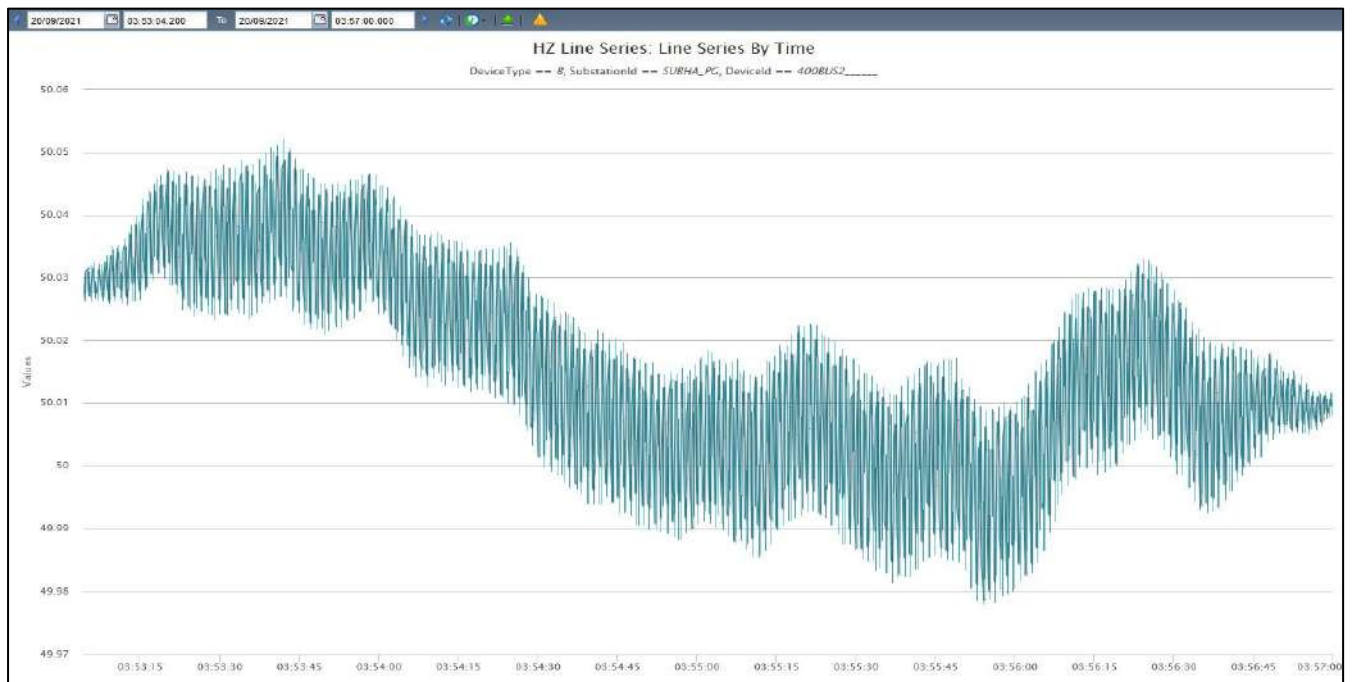

**Durgapur Frequency:** Frequency variation in Durgapur was comparatively less as moving away from Subhasgram

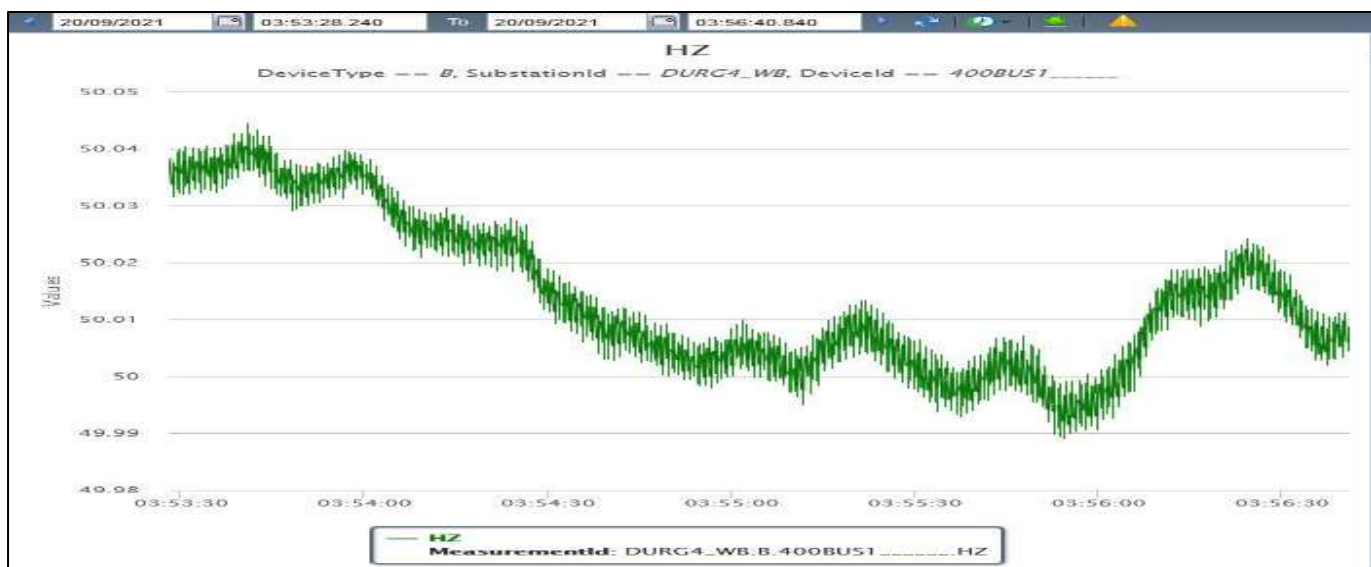

**Mode : 0.8 to 0.9 hz (Local mode)** ,This also indicates towards oscillation of any plant against the whole grid of Hunting of any unit due to any problem.

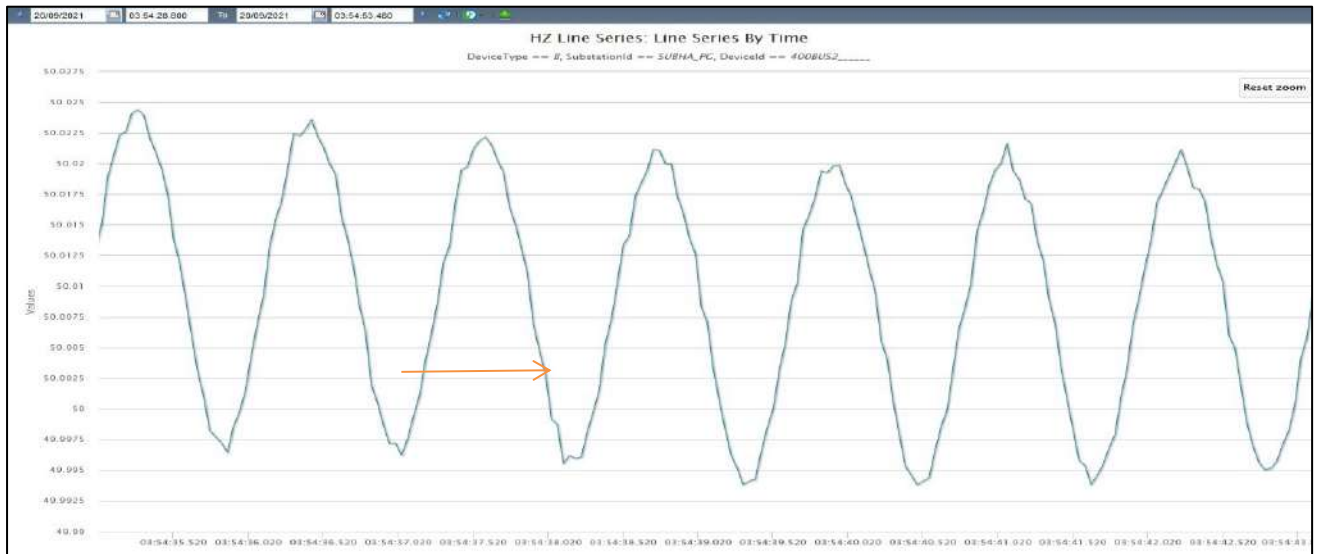

**Power Spectral Density** as shown below also shows that the highest energy is of 0.8-0.9Hz .

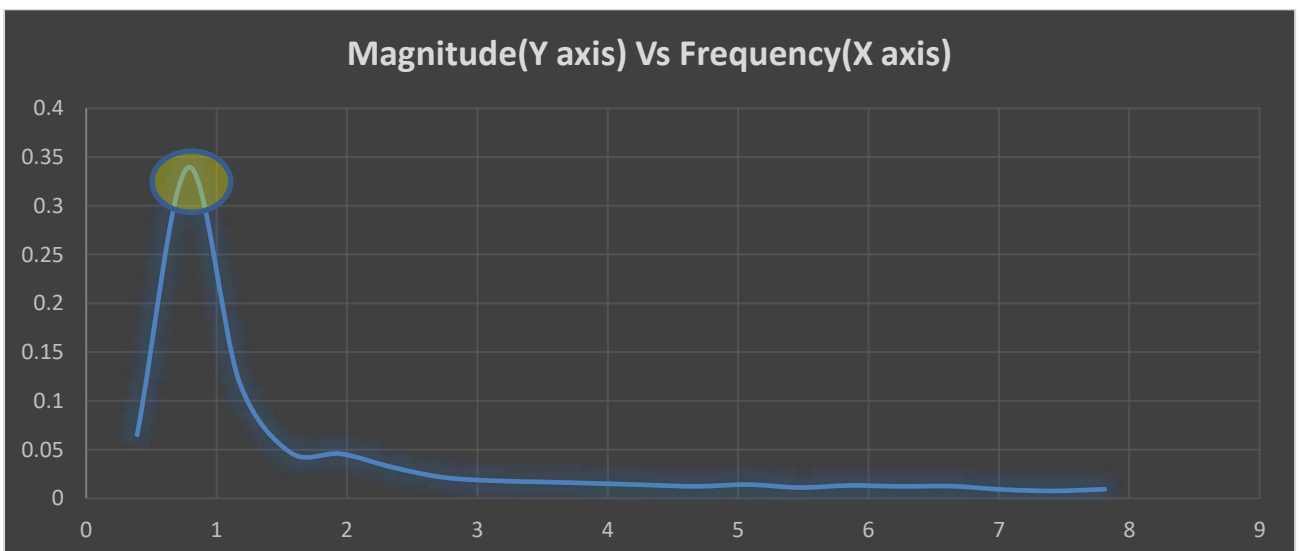
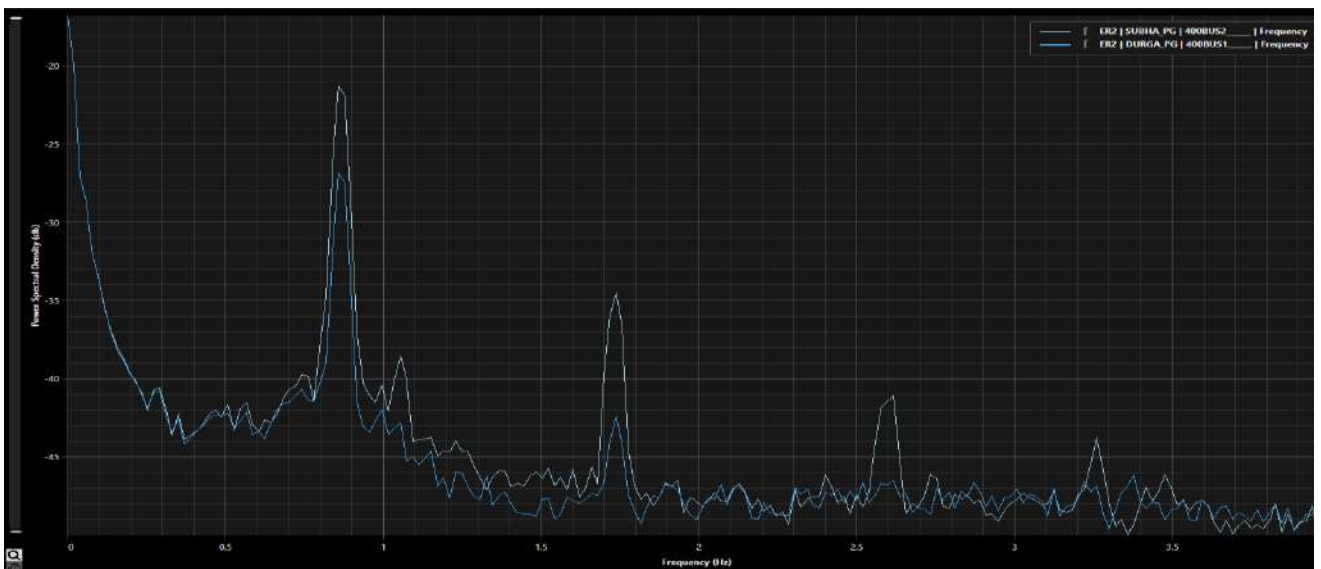

Above signal conditioning PSD and FFT of plot also shows Prominent mode of oscillating frequency 0.8-0.9 Hz (Local mode).

**Critical modes as observed** from below plot can be seen as between 0.8-0.9Hz with damping ratio less than 5%

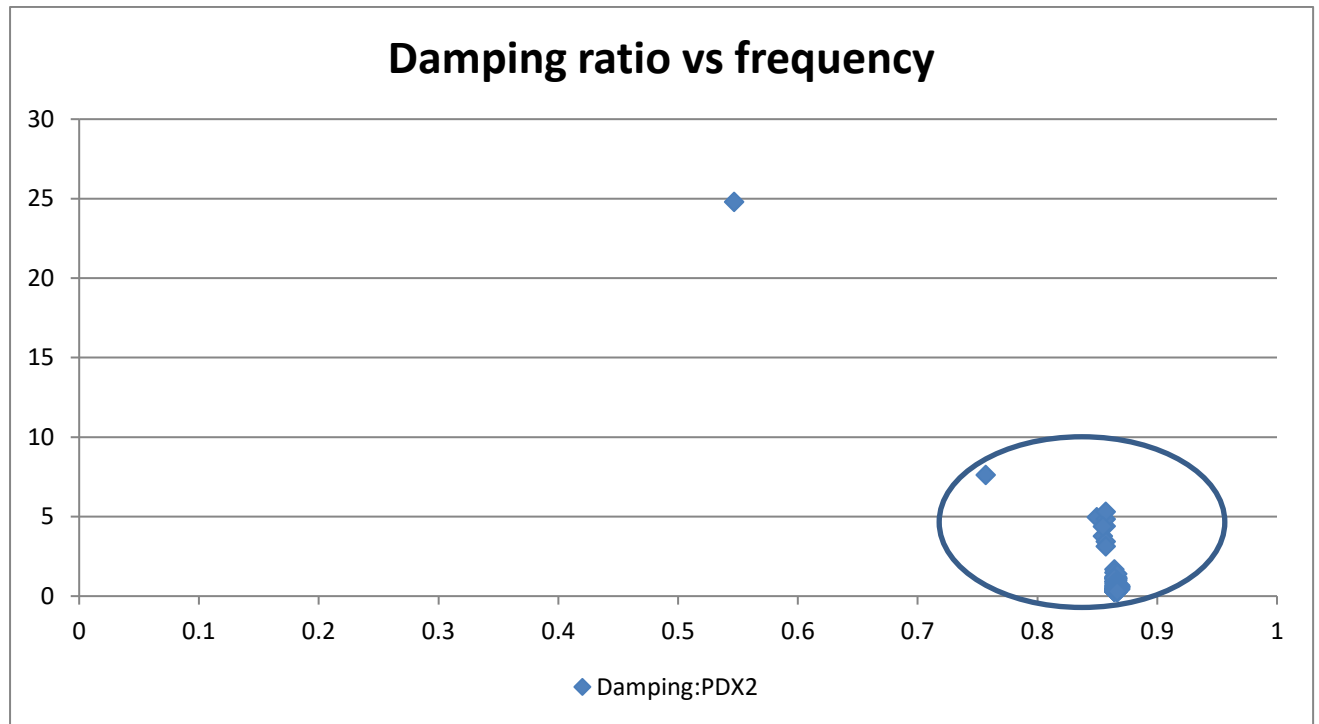

**Ringdown and application of Prony Method: 0.875Hz with Damping ratio of 0.23 Hz**

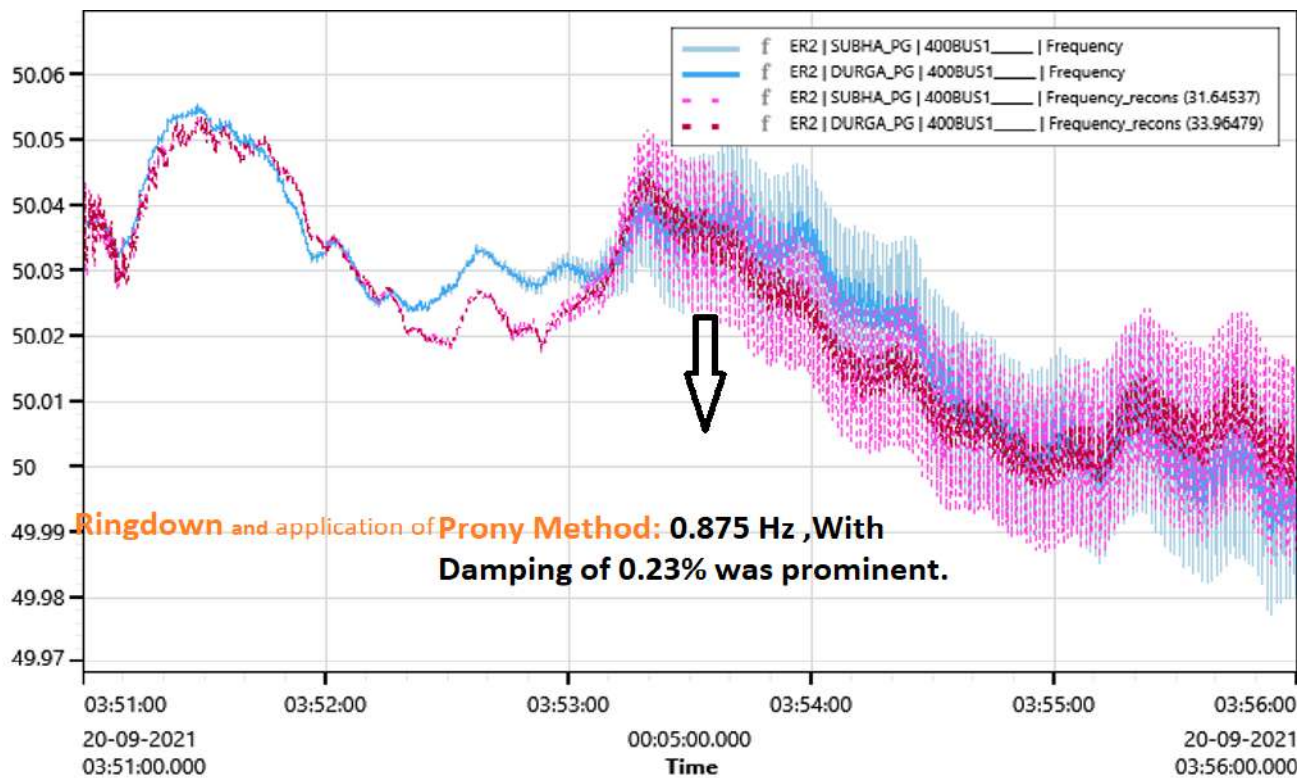



## SOURCE OF OSCILLATION:

Scada plot of active power variation of Nearby units:

**Farakka –Kahalgaon generation:**

Farakka overall plant wise only 10 Mw variation unit wise it was only 2 to 3 Mw.

While Kahalgaon no variation observed. This also indicates as we are moving further away from Subhasgram ,units are having less impact .

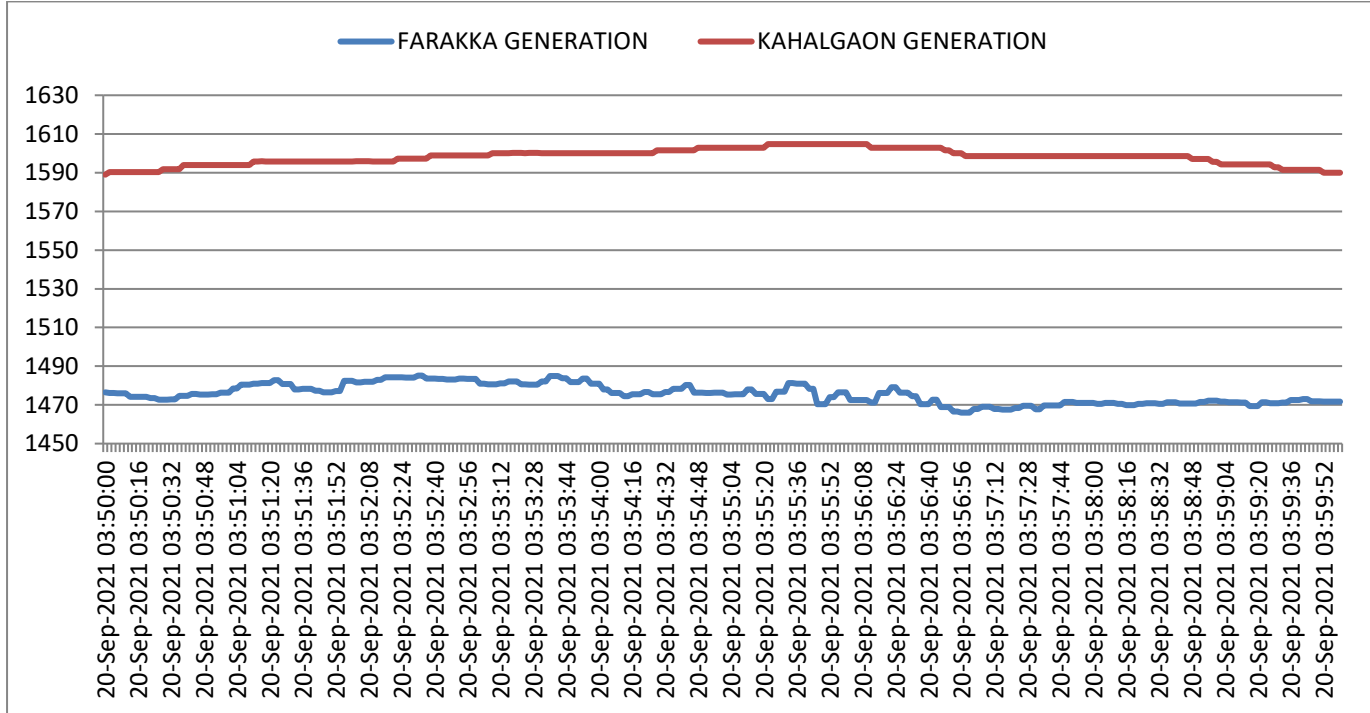

**HALDIA GENERATION VARRIATION:** 10 TO 20 Mw in each unit of Haldia observed .

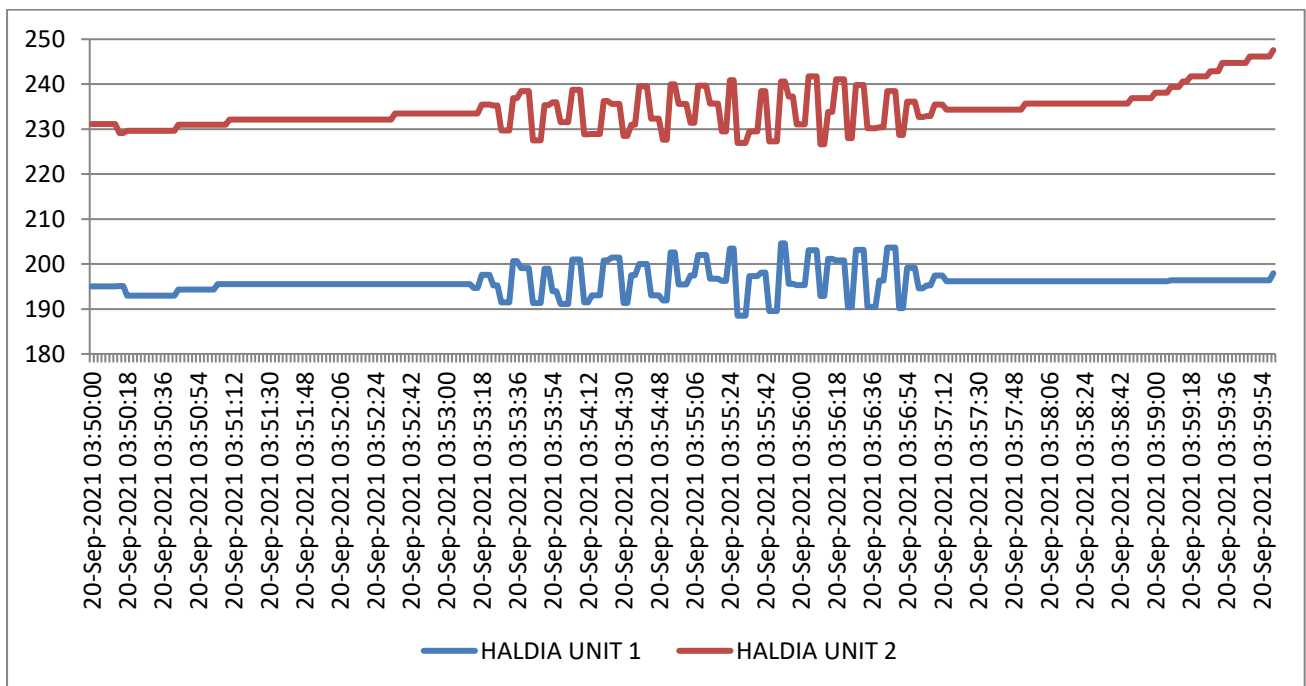

Same was also observed in Haldia Subhasgram power flow variation: 10 Mw variation in each circuit observed as Haldia generation varied.



It was most prominent in Budge-budge units: 140 to 160 Mw variation observed in each unit ,which is maximum and hunting of these units seems to be the source of oscillation .CESC also observed the hunting in these units.

**Unit wise variation of Budge-budge Plant:**

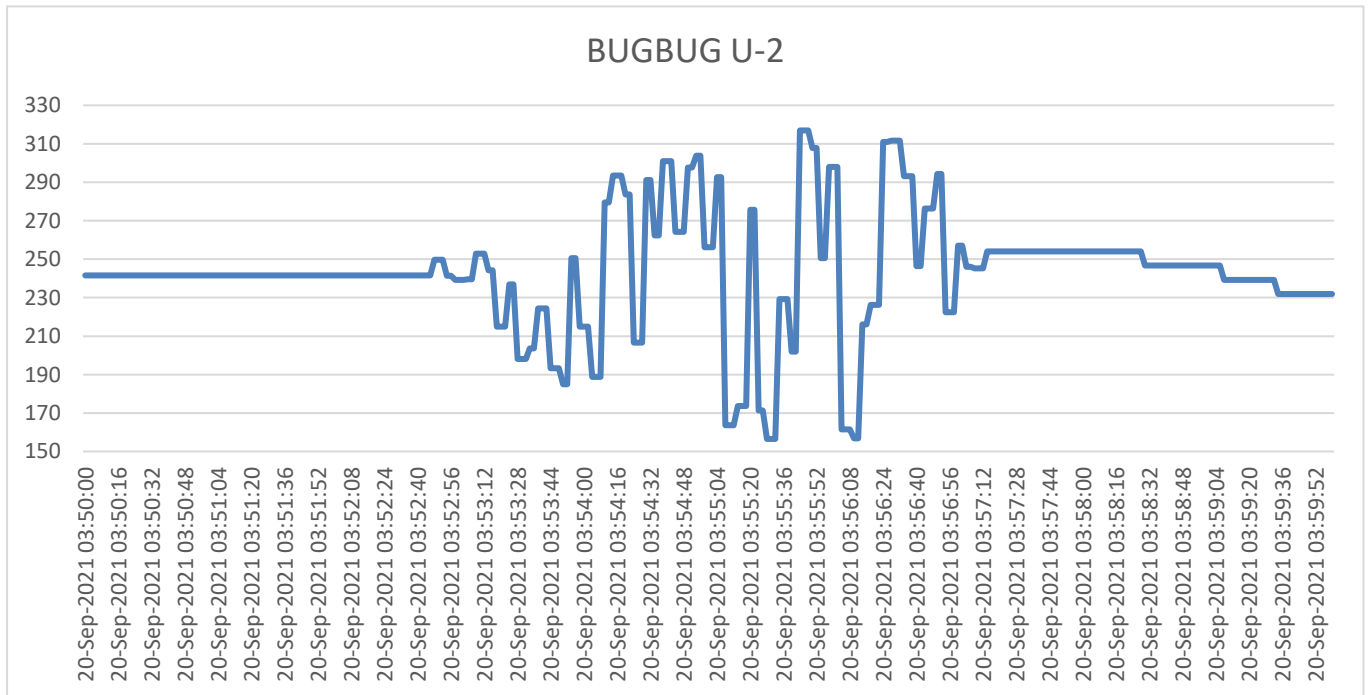

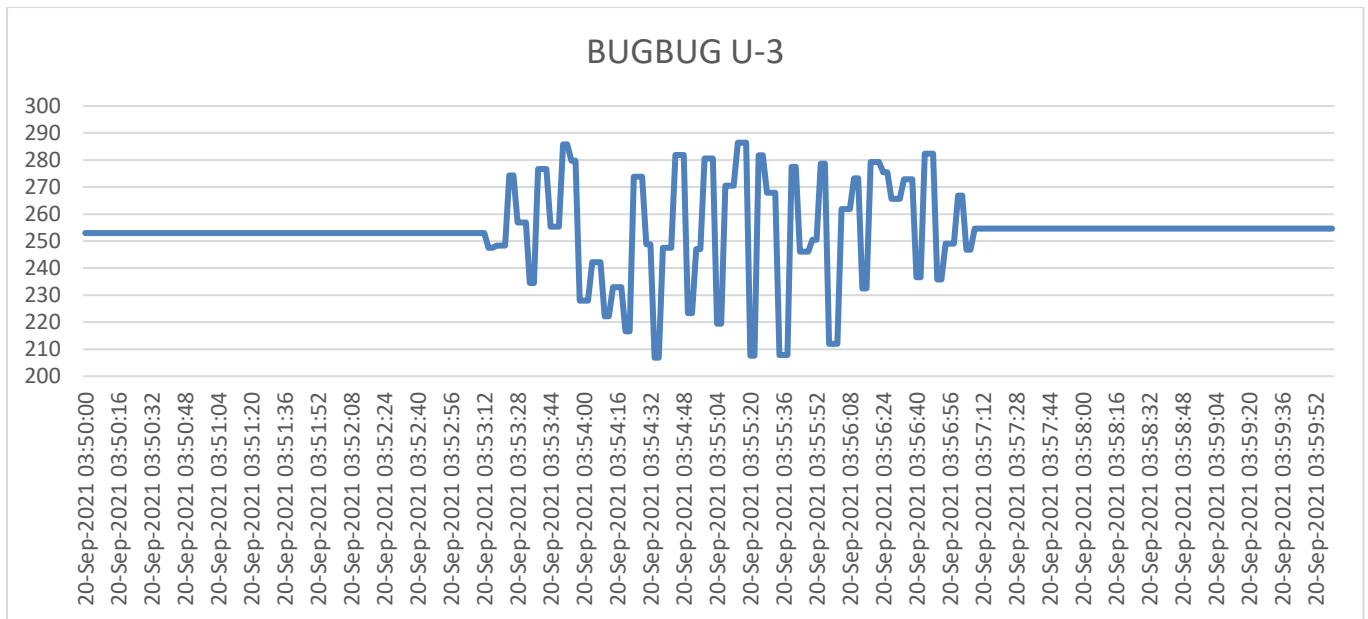

As observed from the above plots maximum variation in MW oscillation was observed for Budge-budge units ,which appears to be the source of oscillation as the Mw variation damped out ,oscillation was also damped .

At 03:46 Hrs BUDGE-BUDGE unit -1 was taken out due to suspected ash bridging over bottom ash hopper and after 8 minutes of taking unit 1 out hunting started .

**Detailed root cause analysis from CESC and reasons are required for the hunting of BUDGE-BUDGE units .**

## EVENT OF SMELTER LOAD TRIPPING ON 28<sup>th</sup> September

### Sterlite SLD:

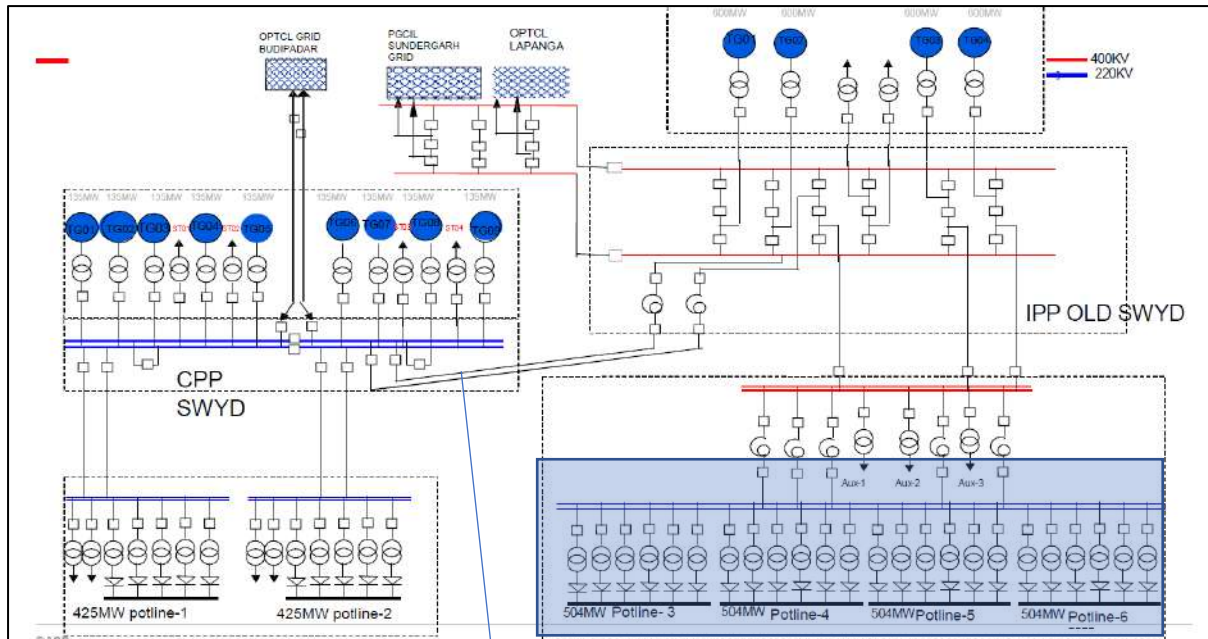

400 & 220 kv are decoupled with each other.

Smelter load at 400 Kv.

### Plant scenario prior to event:

- Unit 3 was out and Unit 1,2&4 was running with total generation of 1232 Mw.
- Sterlite was drawing 258 Mw from Grid ,so total load was 1490 MW.

At 17:48 Hrs due to fault in downstream within 400 kv Sterlite switchyard ,Smelter load reduced by 1450 Mw .

- As Sterlite load reduced ,Sterlite started exporting to the grid by 1182 Mw so total load reduced was 1450 Mw .
- At Sterlite SPS is there to take care of Huge injection in the grid which was set at 800Mw whenever injection is more than 800 MW it will limit it by generation reduction logic .
- Hence total generation to be reduced to limit till 800 Mw was ,1182-800= 382 Mw.

As per logic shown below priority 6 was satisfied

So generator 1 HP,LP Bypass occurred with generator 1 shedding which reduced the grid export within 800 Mw within 1 minutes .

Accumulated generation shed table	Priority	MW
GEN2 HPLP	1	81.417
GEN2 HPLP+GEN1 HPLP	2	225.621
GEN2HPLP+GEN1 HPLP+GEN 4 HPLP	3	369.45
GEN2HPLP+GEN1 HPLP+GEN 4 HPLP+GEN3 HPLP	4	369.45
GEN2	5	271.39
GEN2+ GEN1 HPLP	6	415.594
GEN2+ GEN1 HPLP+GEN4 HPLP	7	559.423
GEN2+ GEN1 HPLP+GEN4 HPLP+GEN 3 HPLP	8	559.423
GEN2+GEN1	9	752.07
GEN2+GEN1+GEN4 HPLP	10	895.899
GEN2+GEN1+GEN4 HPLP+GEN3 HPLP	11	895.899
GEN2+GEN1+GEN4	12	1231.5
GEN2+GEN1+GEN4+GEN3 HPLP	13	1231.5
GEN2+GEN1+GEN4+GEN3	14	1231.5

**ODISHA schedule vs Draw**

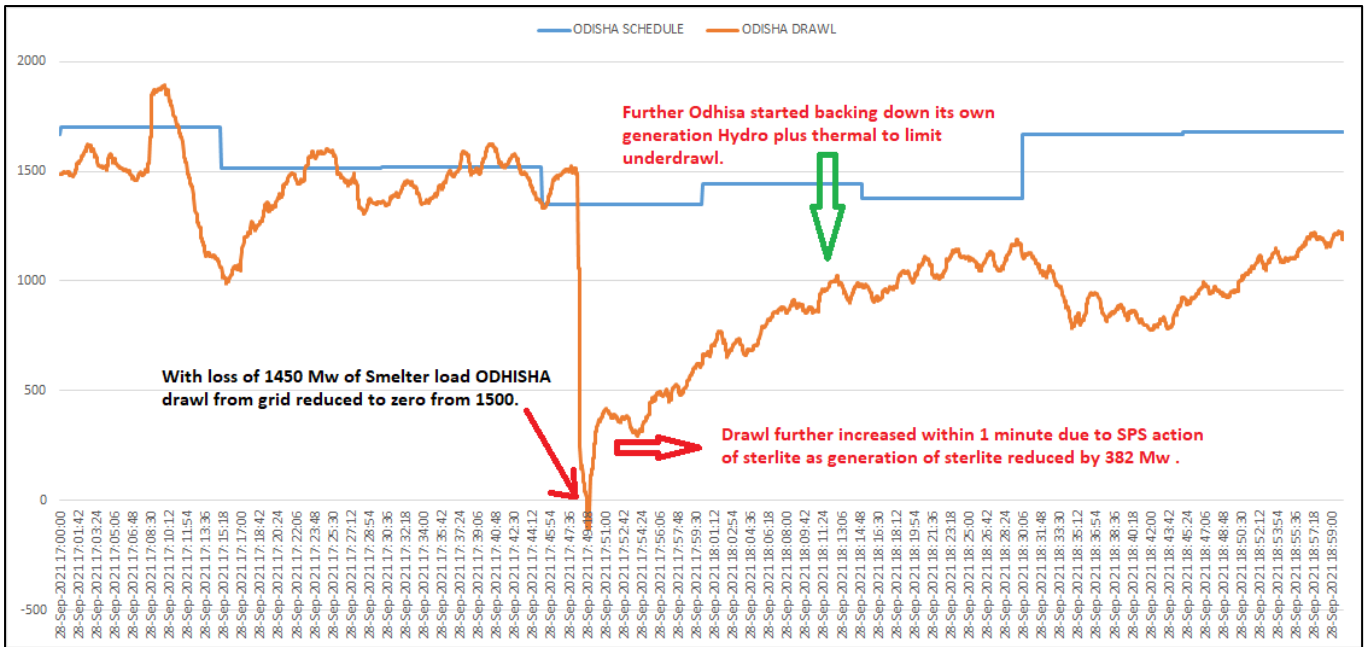

**Sterlite Draw from Grid:**

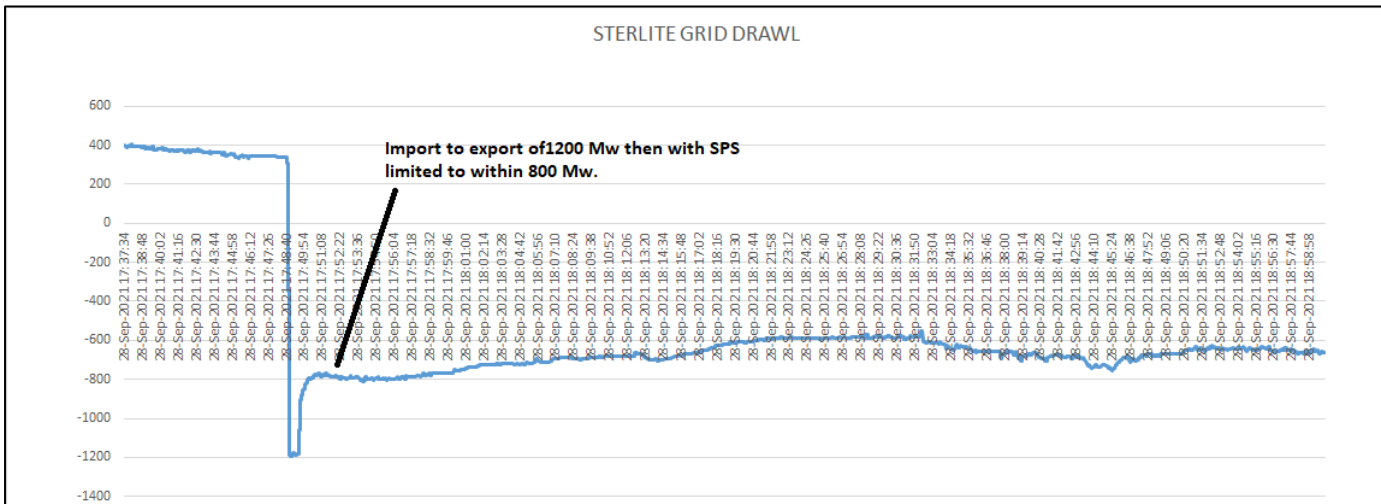

# Existing Arrangement

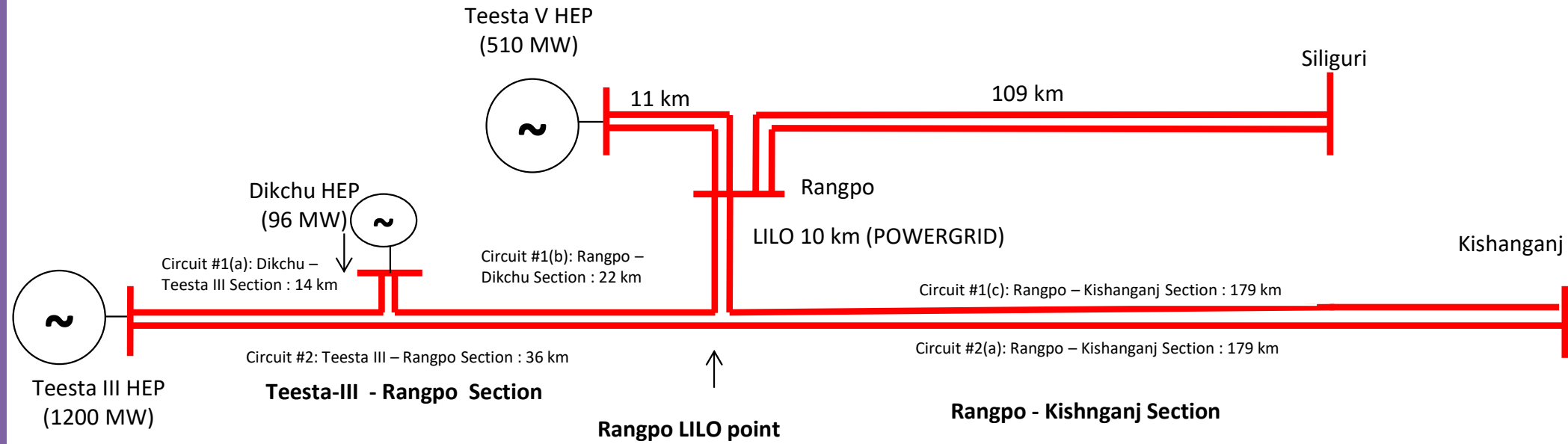

# Probable Arrangement after LILO works of CKT-II

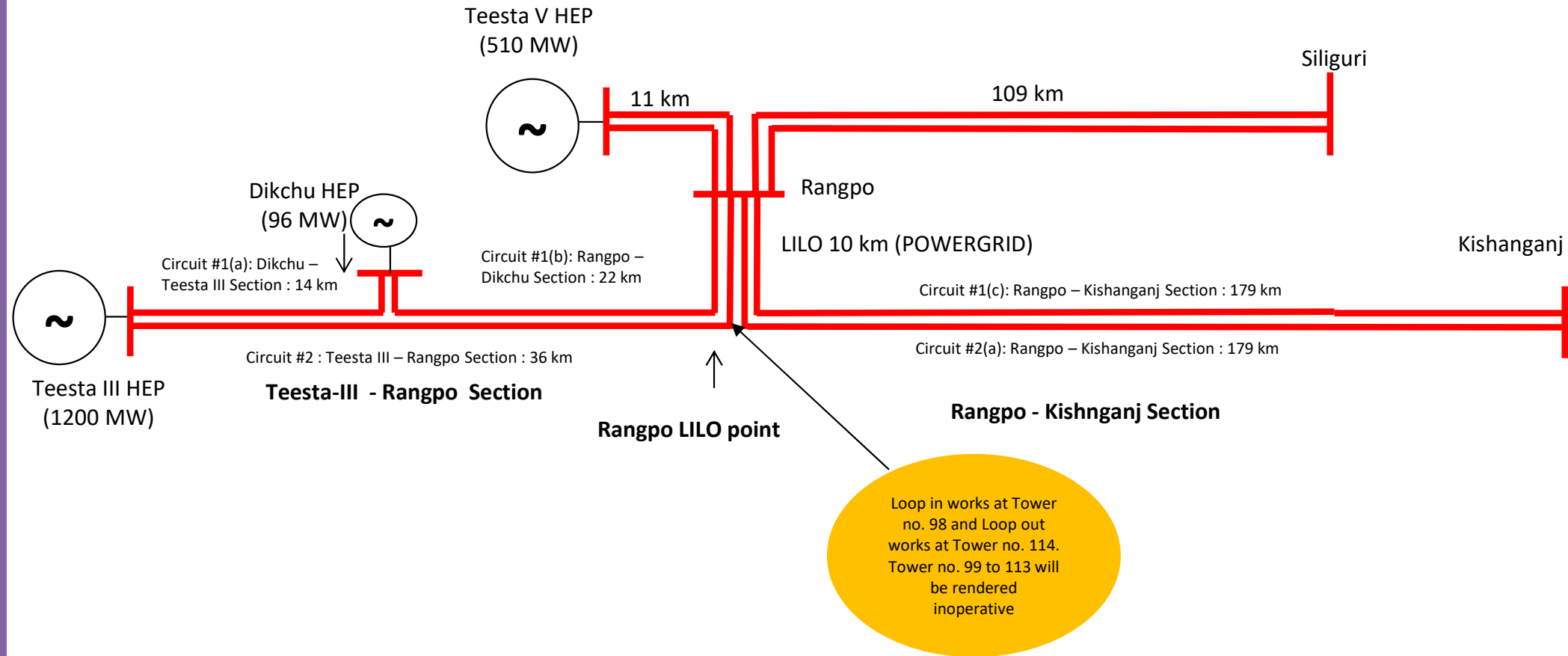





दामोदर घाटी निगम

**Damodar Valley Corporation**

मुख्य अभियंता-1 (एस.एल.डी.सी) का कार्यालय,

हावड़ा सब-स्टेशन, 31/1, आंदुल रोड,

डाकघर- दानेश शेख लेन,

जिला-हावड़ा - 711 109, पं. बंगाल, Howrah, West Bengal

दूरभाष: 033-2688 5019

Fax: 033-2688 5094

Office of the Chief Engineer-I, SLDC

31/1 Andul Road

PO. Danesh Shek Lane-711109

email: [dvcsldc@gmail.com](mailto:dvcsldc@gmail.com)

No. SLDC/25/ERPC/1943

Date: 15-12-2021

प्रति / To,

The Member Secretary, ERPC,  
14, Golf Club Road, Tollygunge,  
Kolkata - 700 033.

बिषय / Sub: Request for kind vetting of 'Force Majeure' condition

संदर्भ / Ref: Request from OS&U Dept., DVC, Kolkata for exemption of loss of DC on ground of force majeure situation, vide letter no-EDCON/OS&U/Correspondence/294 dated 15-12-2021,-copy attached.

Dear Sir,

Reference is invited to the captioned letter from OS&U Dept., DVC intimating a flood-like situation in the Bankura district and Asansol because of the incessant rainfall on 29.09.2021 to 30.09.2021 owing to the formation of a low-pressure area created over Gangetic West Bengal. The unprecedented rainfall in the lower valley area of DVC caused inundation in Mejia Thermal Power Station (MTPS) & Durgapur Steel Thermal Power Station (DSTPS).

In this context OS&U Dept., DVC has requested for exemption of loss of DC of MTPS#1,2,4 & 8 and DSTPS#1,2 on ground of force majeure condition. The appeal along with the relevant data and documentary proof of the above inundated condition, furnished by OS&U Dept., DVC, is hereby attached for your kind perusal.

The outage details of DSTPS units were also minuted in the 184<sup>th</sup> OCC, copy attached.

In view of above, appeal of OS&U Dept., DVC is recommended for kind vetting of force Majeure condition by ERPC for subsequent certification of the requested DC from SLDC, DVC end.

Encl: As stated above.

आपका विश्वस्त,

*[Handwritten Signature]*  
15/12/21

मुख्य अभियंता (विद्युत)

एस. एल. डी. सी, हावड़ा

Copy to:

1. The Executive Director, ERLDC, 14, Golf Club Road, Tollygunge, Kolkata-700033.
2. The Executive Director, Commercial, DVC, Kolkata - 700054.
3. The Executive Director, Operation, DVC, Kolkata - 700054.
4. The Chief Engineer-I, OS&U, DVC, Kolkata - 700054.



## Annexure-C4

POWER SYSTEM DEVELOPMENT FUND													
Status of the Projects in Eastern Region													
Sl No	State	Entity	Name of the scheme	Grant Approved	Grant sanctioned on	1st Installment grant released on	Completion Schedule	Completion schedule w.r.t date of 1st instalment	Grant aviled so far	Under process of release	Total awards amount of placed of till date	Latest status	
1	Bihar	BSPTCL	Renovation and Upgradation of protection system of substations. (18)	64.22	42135	42506	24	43236	56.04		69.195	90% grant availed on award cost.	
2			Installation of Capacitor bank in 20 Nos of Grid Sub Station. (74)	18.882	42618	43550	24	44281	16.99		21.55		
			<b>Total</b>	<b>83.10</b>					<b>73.03</b>		<b>90.745</b>		
5	Jharkhand	JUSNL	Renovation & Upgradation of protection system of Jharkhnad. (161)	138.13	15-Nov-17	28-Mar-19	16	28-Jul-20	114.68	1.01	145.674	90% grant availed on award cost. Project closure is expected by Q-2 of 2021-22.	
6			Reliable Communication & data acquisition system upto 132kV Substations ER. (177)	22.36	24-May-19		24						Price bid has been opened. Tender on awarding stage.
			<b>Total</b>	<b>160.49</b>					<b>114.68</b>		<b>145.674</b>		
7	Odisha	OPTCL	Renovation and Upgradation of protection system of substations. (08)	162.50	11-May-15	22-Mar-16	24	22-Mar-18	46.04		63.31	Project Completed on Dec-20. Request for release of final 10 % fund has been placed.	
8			Implementation of OPGW based reliable communication at 132 kv and above substations. (128)	25.61	15-Nov-17	29-Mar-19	36	29-Mar-22	23.04			51.22	90% grant availed on award cost. Work In Progress
9			Installation of 125 MVAR Bus Reactor along with construction of associated by each at 400kV Grid S/S of Mendhasal, Meramundali & New Duburi for VAR control & stabilisation of system voltage. (179)	27.23	27-Jul-18	1-Apr-19	18	1-Oct-20	8.17			24.5	90% grant availed . Rest work in progress
10			Implementation of Automatic Demand Management System (ADMS) in SLDC, Odisha. (196)	2.93	24-May-19	19-Feb-20	10	19-Dec-20	0.29			0.29	10% grant availed
11			Protection Upgradation and installation os Substation Automatic System (SAS) for seven nos of 220/132/33kV Substations (Balasore, Bidanasi, Budhipadar, Katapali, Narendrapur, New-Bolangir & Paradeep). (209)	29.56	24-May-19	13-Feb-20	18	13-Aug-21	8.87			32.85	30% grant availed. Work in Progress.
12		OHPCL	Renovation and Upgradation of protection and control system of OHPC. (109)	22.35	22-May-17	25-May-18	24	25-May-20	14.94			21.25	90% grant availed on award cost.
			<b>Total</b>	<b>270.18</b>					<b>101.35</b>		<b>193.42</b>		
14	West Bengal	WBSETCL	Installation of switchable reactor & shunt capacitor for voltage improvement. (88)	43.37	22-May-17	22-Jun-18	19	22-Jan-20	33.07		40.83	90% grant availed on award cost. Will get completed by Oct'21	
15			Renovation & Modernisation of Transmission System. (87)	70.13	22-May-17	25-Jun-18	25	25-Jul-20	63.12			96.44	90% grant availed on award cost. Will get completed by Mar'22
16			Installation of Bus Reactors at different 400kV Substation within the state of West Bengal for reactive power management of the Grid. (210)	71.74	24-May-19	23-Oct-19	19	23-May-21	39.3			45.62	30% grant availed on award cost. 04 Nos. of Reactors will be commissioned by December 2021. LoA of the 5th Reactor is yet to be placed.
17			Project for establishment of reliable communication and data acquisition at different substation at WBSWTCL. (222)	31.19	24-May-19	23-Oct-19	25	23-Nov-21	3.12				The tender has been been cancelled for OPGW. Re-tendering has to be done.
18			Implementation of Integated system for Scheduling, Accounting, Metering and Settlement of Transactions (SAMAST) system in West Bengal. (197)	10.08	43910		12						10% grant not yet requested
19		WBPDCL	Renovation and Modernization of 220/ 132 kV STPS switch yard and implementation of Substaion Automation System. (72)	23.48	5-Sep-16	18-May-17	18	18-Nov-18	21.13			32.09	Target date for completion of project is Sept.'21 subject to availability of S/D & Covid scenario. Request for release for final 10% grant has been placed.
21	WBPDCL	Renovation and Modernization of switchyard and related protection system of different power stations (BTPS, BKTPS and KTPS) of WBPDCL (155)	45.16	27-Jul-18	27-Mar-19	12	27-Mar-20	34.52			41.68	Target date for completion of project is Oct'21, subject to availability of S/D & Covid scenario. 90% grant availed on award cost.	
			<b>Total</b>	<b>295.15</b>					<b>194.26</b>		<b>256.661</b>		

POWER SYSTEM DEVELOPMENT FUND												
Status of the Projects in Eastern Region												
Sl No	State	Entity	Name of the scheme	Grant Approved	Grant sanctioned on	1st Installment grant released on	Completion Schedule	Completion schedule w.r.t date of 1st instalment	Grant aviled so far	Under process of release	Total awards amount of placed of till date	Latest status
22	DVC	DVC	Renovation and Upgradatg of the protection and control system of Ramgarh Sub Station. (81)	25.96	2-Jan-17	31-May-17	24	31-May-19	22.95	2.57	28.603	90% grant availed on award cost.
23			Renovation and Modernization of control and protection system and replACEMENT of equipment at Parulia, Durgapur, Kalyanewari, Giridhi Jamsedpur, Barjora, Burnpur, Dhanbad and Bundwan substation. (106)	140.50	16-May-17	14-Dec-17	24	14-Dec-19	102.43	0.98	127.684	
<b>Total</b>				<b>166.46</b>				<b>125.38</b>		<b>156.287</b>		
24	Sikkim	ENPD, Sikkim	Drawing of optical ground wire (OPGW) cables on existing 132kV & 66kV transmission lines and integration of leftover substations with State Load Despatch Centre, Sikkim. (173)	10.00	24-May-19		18		3.00		20	30% grant availed on award cost
<b>Total</b>				<b>10.00</b>					<b>3.00</b>		<b>20.00</b>	
26	ERPC	ERPC	Creation and Maintenance of web based protection database management. (67)	20.00	17-Mar-16	28-Jun-16	18	28-Dec-17	14.83		16.48	Project Completed
27			Study Programme on power trading at NORD POOL Academy for Power System Engineers of Eastern Region. (122)	5.46	27-Jul-18	27-Mar-19	13	27-Apr-20	4.61		5.37	
28			Traning Program for Power system Engineers of various constituents of Eastern Region. (117)	0.61	27-Jul-18	11-Apr-19	24	11-Apr-21	0.54		0.60888	90% grant availed on award cost.
<b>Total</b>				<b>26.07</b>					<b>19.98</b>		<b>22.45888</b>	
<b>GrandTotal</b>				<b>1,011.46</b>					<b>631.68</b>		<b>885.25</b>	

## Date of PFR testing scheduled /completed for generating stations in ER

Sr. No	Station	Generating Unit	Test schedule	Remarks
1	TALCHER STAGE 2	3	Unit 3 - 5: 23-11-2020 to 28-11-2020	Testing for unit 6 yet to be conducted
2		4		
3		5		
4		6		
5	Farakka	2	01-02-2021 to 10-01- 2021	Testing completed
6		3		
7		4		
8		5		
9		6		
10	Kahalgaon	1	August'21	Testing completed for Unit 1
11		5		
12		6		
13		7		
14	Barh	4	18-02-2021 to 21-02- 2021	Scheduled
15		5		
16	Teesta V	1	07-01-2021 - 08-01-2021	Testing completed
17	Teesta III	1	30-01-2021 - 10-02-2021	Testing completed
18		2		
19		3		
20		4		
21		5		
22		6		
23	Dikchu	1	Unit#1: 6th & 7th April' 21 Unit#2: 8th & 9th April' 21	Scheduled
24		2		
25	MPL	1	-	Postponed due to some technical issue
26		2		
27	GMR	1	August'21	Testing Completed
28		2		
29		3		
30	JITPL	1	August'21	Scheduled
31		2		
32		3		
33	NPGCL	1	August'21	Testing Completed
34	BRBCL		1 <sup>st</sup> Week of August'21	Testing Completed
35	APNRL	1&2	July'21-August-21	Testing Completed

## Annexure C8

Power Plant	Unit No	PSS tuned (Yes/No)	PSS in Service (Yes/No)	Last PSS Tuning Date	Whether Done in Last 3 Years	Whether Next to be planned	Planned Next PSS Tuning
<b>West Bengal</b>							
Kolaghat-WBPDCL	1	No	Yes	Long Back	No	Yes	Under retirement
Kolaghat-WBPDCL	2	No	Yes	Long Back	No	Yes	Under retirement
<b>Kolaghat-WBPDCL</b>	<b>3</b>	No	Yes	Long Back	No	Yes	To be done within Jan./Feb. 2022 after DAVR replacement.
<b>Bakreshwar-WBPDCL</b>	<b>2</b>	Yes	Yes	2019	Yes	Yes	PSS tuning to be done during Unit O/H in the month of November-December, 2021
<b>Bakreshwar-WBPDCL</b>	<b>4</b>	Yes	Yes	2019	Yes	Yes	BHEL offer received. PSS tuning to be done within Dec , 2021
<b>Bakreshwar-WBPDCL</b>	<b>5</b>	Yes	Yes	2019	Yes	Yes	BHEL offer received. PSS tuning to be done within Dec , 2021
DPL	8	No	Yes	No	No Detail	Yes	To be updated by WBPDCL/DPL
PPSP	1	No	Yes	2009	No	Yes	Dec-21
PPSP	2	No	Yes	2009	No	Yes	Dec-21
PPSP	3	No	Yes	2009	No	Yes	Dec-21
PPSP	4	No	Yes	2009	No	Yes	Dec-21
TLDP III	4 x 33			No Detail	No Detail	Yes	To be updated by WBSEDCL
TLDP IV	4 X 44			No Detail	No Detail	Yes	To be updated by WBSEDCL
<b>DVC</b>							
Bokaro B 210 MW	3				No Detail	Yes	Unit Is out of Service
Raghunathpur-DVC	1	No	No		No Detail	Yes	Will be done after AOH
Raghunathpur-DVC	2	No	No		No Detail	Yes	Jun-21
Waria	4	Yes	Yes	2008	No	Yes	Unit Is out of Service
<b>ISGS</b>							
Kahalgaon NTPC	1	Yes	Yes	2017	Yes	Yes	Apr-21
Kahalgaon NTPC	3	Yes	Yes	2016	Yes	Yes	Jul-21
Kahalgaon NTPC	4	Yes	Yes	2015	No	Yes	Mar-21
Kahalgaon NTPC	6	Yes	Yes	2009	No	Yes	Mar-21
Talcher Stage 2	3	Yes	Yes	2016	Yes	Yes	Nov-21
Talcher Stage 2	4	Yes	Yes	No Details	No Details	Yes	Nov-21

Talcher Stage 2	5	Yes	Yes	No Details	No Details	Yes	Nov-21
Talcher Stage 2	6	Yes	Yes	2016	Yes	Yes	Nov-21
Barh NTPC	4			2015		Yes	In Next AOH
Barh NTPC	5			During Unit commissioning		Yes	June 2021 (AOH)
Teesta V	1	Yes	Yes	2008	No	Yes	Oct-21
Teesta V	2	Yes	Yes	2008	No	Yes	Oct-21
Teesta V	3	Yes	Yes	2008	No	Yes	Oct-21
BRBCL	1	No	Yes	Vendor to Do	No	Yes	Jun-21
BRBCL	2	Yes	Yes	2019	Yes	Yes	Jun-21
BRBCL	3	No	Yes	Vendor to Do	No	Yes	Jun-21
KBUNL	1	Yes	Yes	2014	No	Yes	2021-22
KBUNL	2	Yes	Yes	2014	No	Yes	2021-22
KBUNL	3	Yes	Yes	Not Available	No	Yes	2021-22
KBUNL	4	Yes	Yes	Not Available	No	Yes	2021-22
Rangit	3 x 20			Not Available	No	Yes	To be updated by NHPC
<b>IPP</b>							
Jorethang	1	Yes	Yes	2015	No	Yes	Apr-21
Jorethang	2	Yes	Yes	2015	No	Yes	Apr-21
ADHUNIK	1	Yes	YES	2013	No	Yes	Mar-21
ADHUNIK	2	Yes	YES	2013	No	Yes	Mar-21
JITPL	1	Yes	Yes	2016	Yes	Yes	Jul-21
JITPL	2	Yes	Yes	2016	Yes	Yes	Jul-21
GMR	1	Yes	Yes	2013	No	Yes	Dec-21
GMR	2	Yes	Yes	2013	No	Yes	Dec-21
GMR	3	Yes	Yes	2013	No	Yes	Dec-21
<b>Orissa</b>							
IB TPS	1	Yes	Yes	2011	No	Yes	Mar'2021
IB TPS	2	Yes	Yes	2012	No	Yes	Mar'2021
Upper Indravati	1	Yes	No	2015	No	Yes	To be updated by OHPC
Upper Indravati	2	Yes	No	2015	No	Yes	To be updated by OHPC
Upper Indravati	3	Yes	No	2000	No	Yes	To be updated by OHPC
Upper Indravati	4	Yes	No	2001	No	Yes	To be updated by OHPC
Balimela	1 (60 MW)			No detail		Yes	To be updated by OHPC

Balimela	2 (60 MW)			No detail		Yes	To be updated by OHPC
Balimela	3 (60 MW)	No	No	Not tuned	No	Yes	To be updated by OHPC
Balimela	4 (60 MW)	No	No	Not tuned	No	Yes	To be updated by OHPC
Balimela	5 (60 MW)	No	No	Not tuned	No	Yes	To be updated by OHPC
Balimela	6 (60 MW)	No	No	Not tuned	No	Yes	To be updated by OHPC
Balimela	7 (75 MW)	No	No	Not tuned	No	Yes	To be updated by OHPC
Balimela	8 (75 MW)	No	No	Not tuned	No	Yes	To be updated by OHPC
Upper Kolab	1	Yes	Yes	2007	No	Yes	To be updated by OHPC
Upper Kolab	2	Yes	Yes	2007	No	Yes	To be updated by OHPC
Upper Kolab	3	Yes	Yes	2007	No	Yes	To be updated by OHPC
Upper Kolab	4	Yes	Yes	2007	No	Yes	To be updated by OHPC
Rengali	1	Yes	Yes	Not tuned	No	Yes	To be updated by OHPC
Rengali	2	Yes	Yes	Not tuned	No	Yes	To be updated by OHPC
Rengali	3	Yes	Yes	Not tuned	No	Yes	To be updated by OHPC
Rengali	4	Yes	Yes	Not tuned	No	Yes	To be updated by OHPC
Rengali	5	No	Yes	Not tuned	No	Yes	To be updated by OHPC
Sterlite	4 X 600			No detail		Yes	To be updated by SLDC
<b>Jharkhand</b>							
Tenughat	1	Yes	Yes	2017	Yes	Yes	Dec-21
Tenughat	2	Yes	Yes	2017	Yes	Yes	Dec-21
Subarnrekha	2 X 65					Yes	To be updated
<b>Bihar</b>							
BTPS	6 (110)					Yes	To be updated by BSPGCL
BTPS	7 (110)					Yes	To be updated by BSPGCL
BTPS	8					Yes	To be updated by BSPGCL
BTPS	9					Yes	To be updated by BSPGCL
<b>Bhutan</b>							
Tala	1	No	Yes			Yes	To be updated by BPC
Tala	2	No	Yes			Yes	To be updated by BPC
Tala	3	No	Yes			Yes	To be updated by BPC
Tala	4	No	Yes			Yes	To be updated by BPC
Tala	5	No	Yes			Yes	To be updated by BPC
Tala	6	No	Yes			Yes	To be updated by BPC
Chukha	1	No	Yes	2005	No	Yes	To be updated by BPC

Chukha	2	No	Yes	2005	No	Yes	To be updated by BPC
Chukha	3	No	Yes	2005	No	Yes	To be updated by BPC
Chukha	4	No	Yes	2005	No	Yes	To be updated by BPC
Mangdechu	1	No	Yes			Yes	Sep-21
Mangdechu	2	No	Yes			Yes	Sep-21

## Anticipated Peak Demand (in MW) of ER &amp; its Constituents for January 2022

		Demand (MW)	Energy Requirement (MU)
<b>1</b>	<b>BIHAR</b>		
	NET MAX DEMAND	5150	2875
	NET POWER AVAILABILITY- Own Sources	688	226
	Central Sector+Bi-Lateral	5867	3157
	SURPLUS(+)/DEFICIT(-)	1405	508
<b>2</b>	<b>JHARKHAND</b>		
	NET MAXIMUM DEMAND	1830	895
	NET POWER AVAILABILITY- Own Source	359	191
	Central Sector+Bi-Lateral+IPP	1069	529
	SURPLUS(+)/DEFICIT(-)	-402	-175
<b>3</b>	<b>DVC</b>		
	NET MAXIMUM DEMAND	3210	2086
	NET POWER AVAILABILITY- Own Source	5121	3177
	Central Sector+MPL	288	155
	Bi- lateral export by DVC	2280	1696
	SURPLUS(+)/DEFICIT(-) AFTER EXPORT	-81	-450
<b>4</b>	<b>ODISHA</b>		
	NET MAXIMUM DEMAND (OWN)	3800	2344
	NET MAXIMUM DEMAND (In Case of CPP Drawal)	5000	3045
	NET POWER AVAILABILITY- Own Source	3346	2204
	Central Sector	1906	848
	SURPLUS(+)/DEFICIT(-) (OWN)	1452	708
	SURPLUS(+)/DEFICIT(-) (In Case, 600 MW CPP Drawal)	252	7
<b>5</b>	<b>WEST BENGAL</b>		
<b>5.1</b>	<b>WBSEDCL</b>		
	NET MAXIMUM DEMAND	5190	2963
	NET MAXIMUM DEMAND (Incl. B'Desh+Sikkim)	5325	3051
	NET POWER AVAILABILITY- Own Source (Incl. DPL)	4633	2198
	Central Sector+Bi-lateral+IPP&CPP+TLDP	2339	1004
	EXPORT (TO B'DESH & SIKKIM)	5	4
	SURPLUS(+)/DEFICIT(-) AFTER EXPORT	1647	151
<b>5.2</b>	<b>IPCL</b>		
	IPCL Demand	130	84
	IPCL Import	130	84
	SURPLUS(+)/DEFICIT(-)	0	0
<b>5.3</b>	<b>CESC</b>		
	NET MAXIMUM DEMAND	1350	680
	NET POWER AVAILABILITY- Own Source	770	474
	FROM OTHER SOURCE (INCL. IPP/CPP-29-30 MU/M)	310	55
	IMPORT FROM HEL	270	151
	TOTAL AVAILABILITY OF CESC	1350	680
	SURPLUS(+)/DEFICIT(-)	0	0
	<b>WEST BENGAL (WBSEDCL+CESC+IPCL)</b>		
	(excluding DVC's supply to WBSEDCL's command area)		
	NET MAXIMUM DEMAND	6670	3727
	NET POWER AVAILABILITY- Own Source	5403	2672
	CS SHARE+BILATERAL+IPP/CPP+TLDP+HEL	2919	1210
	SURPLUS(+)/DEFICIT(-) BEFORE WBSEDCL'S EXPORT	1652	155
	SURPLUS(+)/DEFICIT(-) AFTER WBSEDCL'S EXPORT	1647	151
<b>6</b>	<b>SIKKIM</b>		
	NET MAXIMUM DEMAND	130	64
	NET POWER AVAILABILITY- Own Source	2	1
	Central Sector	193	74
	SURPLUS(+)/DEFICIT(-)	65	11
	<b>EASTERN REGION</b>		
	NET MAXIMUM DEMAND	20382	11991
	NET MAXIMUM DEMAND (In Case of CPP Drawal of Odisha)	21431	12692
	BILATERAL EXPORT BY DVC	2280	1696
	EXPORT BY WBSEDCL TO SIKKIM & B'desh	5	4
	EXPORT TO B'DESH & NEPAL OTHER THAN DVC	642	187
	NET TOTAL POWER AVAILABILITY OF ER	27161	14444
	(INCLUDING CS ALLOCATION +BILATERAL+IPP/CPP+HEL)		
	SURPLUS(+)/DEFICIT(-)	3852	566
	SURPLUS(+)/DEFICIT(-) (In Case, 600 MW CPP Drawal of Odisha)	2803	-135