



**AGENDA  
FOR  
187<sup>th</sup> OCC MEETING**

**Date: 21.01.2022**

**Eastern Regional Power Committee**

**14, Golf Club Road, Tollygunge**

**Kolkata: 700033**

## **EASTERN REGIONAL POWER COMMITTEE**

**AGENDA FOR 187<sup>TH</sup> OCC MEETING TO BE HELD ON 21.01.2022 (FRIDAY) AT 10:30 HRS**

### **PART – A**

**ITEM NO. A.1: Confirmation of Minutes of 186<sup>th</sup> OCC Meeting held on 22<sup>nd</sup> December 2021 through MS Teams online platform.**

The minutes of 186<sup>th</sup> Operation Coordination sub-Committee meeting held on 22.12.2021 was circulated vide letter dated 11.01.2022.

Members may confirm the minutes of 186<sup>th</sup> OCC meeting.

### **PART B: ITEMS FOR DISCUSSION**

**ITEM NO. B.1: Ensuring resource adequacy to meet high electricity demand during forthcoming summer.**

It is to mention that, highest all India electricity demand more than 200GW was met on 7<sup>th</sup> July 2021 with energy consumption of 4508 MU. It is expected that all India electricity demand may touch 215GW and 130BU/month in terms of energy during upcoming summer months based on estimate at our end. Generally, thermal based generation contributes around 75-82% of the total generation to meet the all-India demand. Hence, availability of thermal machines and fuel adequacy at plant level is vital to meet the forecasted demand of 215GW.

At present, generation from imported coal and gas-based plants is very low due to high market prices of gas and imported coal. Generally, generation at imported coal-based plants was about 300MU/day however it is around 120MU/day currently. This has put additional stress on domestic coal-based generation plants. As per resource adequacy, it is envisaged that around 86% capacity of coal based installed capacity would be required during the peak demand period. The details are provided at **Annexure B.1**.

Therefore, it is important that availability of units and coal/fuel stock is monitored closely and regularly at all plants and it may be discussed among all stake holders in Operation coordination meeting (OCC). Some of the points/suggestions have also been listed in the note given as annexure B.1. This would help in meeting the demand in secure manner.

**Members may discuss.**

**ITEM NO. B.2: Removal of technical minimum schedule support from ISGS plants to facilitate full surrender of power by Constituents.**

As per prevailing practice in Eastern Region, ISGS stations are provided with Technical Minimum schedule support. In the event where sum of requisition from all the beneficiaries falls below technical minimum, the beneficiary schedule is jacked up to provide technical minimum schedule to the generators.

However, in the light of recent CERC Order on Petition No: 60/MP/2019, the practice of jacking up surrendered schedule of beneficiaries shall be withdrawn, except in cases as mandated in

Section 5.7 of detailed Reserve Shutdown Procedure (RSD) (CERC Order No. - L-1/219/2017-CERC), which states:

Quote

*RLDC shall Suo-moto revise the schedule of any generating station as per clauses 6.5.14 and 6.5.20 of the Grid Code to operate at or above technical minimum in the ratio of under-requisitioned quantum (with respect to technical minimum) in the interest of smooth system operation under the following conditions:*

- ✓ *Extreme variation in Weather Conditions*
- ✓ *High Load Forecast*
- ✓ *To maintain reserves on regional or all India basis*
- ✓ *Network Congestion*
- ✓ *Any other event which in the opinion of RLDC/NLDC shall affect the grid security.*

*While doing so, it is possible that the requisition of some beneficiaries may go up to ensure technical minimum. In this case, SLDCs may surrender power from some other inter-State generating station(s) or intra-State generating station(s) based on merit order. The concerned RLDC shall issue R-1 schedule accordingly and this shall be intimated to the concerned generating station, through the scheduling process.”*

Unquote.

As per the deliberations of the Special Meeting held on 30.12.2021 and also in line with the discussion of the 1st Working Committee Meeting held on 10.01.2022 following points were finalized.

1. "Beneficiaries to bear a certain percentage (e.g., 100%, 75%, 50%, 0% etc) of fixed charge (FC) of the URS availed by the availing beneficiary/beneficiaries up to the technical minimum. This FC waive off % to be finalized by the beneficiaries"
2. All the concerned beneficiaries (West Bengal, Bihar, Odisha, Jharkhand, DVC, Sikkim) were advised to finalize their FC waive off % and submit the same to ERPC latest by 14<sup>th</sup> January 2022. Making use of these inputs from the beneficiaries the logic for the methodology would be devised. So, keeping in view about the stipulated timeline as already discussed in the Special Meeting and also in various OCC forums, beneficiaries were requested to submit the data within the given timeline.
3. Further it was deliberated that this FC waive off % was to be submitted on monthly basis. The submitted FC waive off % of the previous month(n-1) would be applied if a beneficiary doesn't submit the waive off % for a particular month(n).

E.g., Say the FC waive off % submitted by West Bengal for the month of February 2022 is 100%. Now the same or revised FC waive off % may be submitted by West Bengal for the month of March 2022. If West Bengal does not submit the FC waive off % for March 2022, 100% FC waive off would be applied for March 2022 and so on.

WBSEDCL vide mail dated 14.01.2022 informed that they are willing to bear **100%** fixed charges (FC) of the proportionate quantum of the URS availed by the availing beneficiaries up to Technical Minimum for the first month (February 2022) which may be revised in the subsequent months.

**Bihar, Odisha, Jharkhand, Sikkim and DVC may confirm their FC waive off %.**

### **ITEM NO. B.3: Replacement of ICT- Powergrid Odisha.**

#### **A. Urgent requirement for replacement of 315MVA, 400/220/33kV ICT#2 at Rengali S/S:**

- I. The BHEL make 315MVA, 400/220/33kV ICT#2 of Rengali Substation was commissioned in 1990 under JTSS Project and the said ICT is of 32 years old (Year of Manufacturing: 1987). The said ICT has completed its useful life of 25 years.
- II. Condition based monitoring/ maintenance of transformers/ reactors like DGA, Tan delta measurement of bushings & windings, oil parameters, Furan analysis, FDS, IR of core insulation etc are being carried out by POWERGRID to know the healthiness. During condition monitoring of the said ICT, violation has been observed in the test parameters and condition of the ICT found not good. M/s CPRI (Third party) was approached by POWERGRID to analyse the test results of said equipment and to know the condition of the equipment. The test results were analysed by CPRI and based on the test results, CPRI has recommended to replace the said unit. The letter of CPRI is enclosed herewith.
- III. Said ICT has already completed more than 25 years of useful service life and due to ageing chances of its failure is always high. Failure of the transformer may result into constraint in meeting power demand of Odisha.
- IV. Therefore, it was proposed to replace the 400kV 3ph BHEL make 315MVA ICT-II at Rengali under ADDCAP. Petition for approval of replacement of the ICT was filed in CERC under JTSS system. CERC has directed POWERGRID to seek approval of RPC.
- V. Based on the 41<sup>st</sup> TCC recommendation (copy relevant portion enclosed at **Annexure-B.3**) in respect of the replacement of old 315 MVA ICTs, the subject 315MVA ICT of Rengali S/S may please be agreed to be replaced with a 500MVA ICT considering increased power requirement, availability and reliability of power supply to the state of Odisha.

#### **B. Urgent Requirement for replacement of 3x105 MVA, 400/220/33KV ICT-1 at Jeypore S/s.**

- I. The BHEL make 3x105MVA, 400/220/33kV ICT#1 of Jeypore Substation was commissioned in 1990 under JTSS Project and the said ICT is of 32 years old (Year of Manufacturing: 1987). The said ICT has already successfully completed its useful life of 25 years.
- II. Condition based monitoring/ maintenance of transformers/ reactors like DGA, Tan delta measurement of bushings & windings, oil parameters, Furan analysis, FDS, IR of core insulation etc are being carried out by POWERGRID to know the healthiness. During condition monitoring of the ICT-I Yph, violation has been observed in the test parameters and condition of the ICT found not good. M/s CPRI (Third party) was approached by POWERGRID to analyse the test results of said unit and to know the condition of the equipment. The test results were analysed by CPRI and based on the test results, CPRI has recommended to replace the said unit. The letter of CPRI is enclosed herewith.
- III. Therefore, Petition for approval of replacement of the ICT was filed in CERC under JTSS system. CERC has directed POWERGRID to seek approval of RPC.
- IV. This is also pertinent to mention here that, the balance 2 Nos. single phase units (R-Ph & B-Ph) of 315MVA ICT#1 had already completed more than 25 years of useful service life and due to ageing chances of its failure is always high. Failure of the transformer may result into constraint in meeting power demand of Odisha. Hence, it is prudent to go for replacement of all the 3 single Phase units with a 500 MVA 3-Ph Unit at Jeypore S/S.

Hence, replacement of the subject 3x105MVA ICT with a new 3ph ICT under O&M ADD-CAP is proposed.

- V. Based on the 41st TCC recommendation (copy relevant portion enclosed at **Annexure-B.3**) in regards to the replacement of old 315 MVA ICTs, the subject 3x105MVA ICT of Jeypore S/S may please be agreed to be replaced with a 500MVA ICT considering increased power requirement, availability and reliability of power supply to the state of Odisha.

**Powergrid may explain. Members may discuss.**

#### **ITEM NO. B.4: Islanding Schemes in Eastern Region.**

##### **B4.1. Implementation of Islanding Schemes in Eastern Region**

In the meeting held on 28<sup>th</sup> December 2020 and chaired by the Hon'ble Minister of State (IC) it was directed that islanding schemes should be implemented for all major cities of the country considering all the strategic and essential loads. Subsequently, in line with the direction given in the meeting, the subject matter was discussed in PCC meeting of ERPC and it was finalized that new islanding scheme would be implemented for capital city of Patna & Ranchi.

##### **I. Patna Islanding Scheme:**

In the special meeting held on 06.08.2021, it was decided that Patna islanding scheme would be designed considering two unit of Nabinagar STPP (2\*660 MW) of NPGCL as participating generator and loads of in and around Patna city. The provision of island formation with one unit of NPGC with corresponding load is also to be included in the island logic.

The islanding frequency & logic will be finalized based on the result of dynamic study to be carried out by SLDC Bihar/ERLDC.

The following timelines were decided:

1. Submission of requisite information by SLDC, Bihar: 2nd week of Aug' 2021.
2. Completion of Islanding simulation study by ERLDC: 4th Week of Aug' 2021
3. Review of islanding study & designing of the logic: By September'2021
4. Implementation & Operationalization of the Islanding Schemes: By March'2022

In 106<sup>th</sup> PCC meeting held on 16.09.2021 it was informed that the requisite information had already been shared by SLDC Bihar and the study is under progress by ERLDC. Further SLDC Bihar was advised to prepare the DPR by September'2021 for PSDF funding, if required.

In the 44<sup>th</sup> TCC Meeting, BSPTCL updated that preparation of DPR for PSDF funding is under process and the same would be completed within 15 days.

TCC stressed on the fact that this issue is being regularly monitored by MoP and advised BSPTCL for timely implementation of the Islanding Scheme.

OCC advised BSPTCL to expedite the matter with Siemens and prepare the DPR as per the said schedule without any further delay.

In the 185<sup>th</sup> OCC meeting, BSPTCL representative mentioned that presently M/s Siemens is carrying out some tests for the preparation of DPR which is scheduled to be completed by last week of November'2021. As soon as the proposal from M/s Siemens is received, they would place the order.

OCC expressed serious concern over the issue and advised BSPTCL to expedite the matter with M/s Siemens at the earliest.

In the 186<sup>th</sup> OCC meeting, BSPTCL representative informed that approval from their higher Management is awaited and the work would be started on receipt of the approval.

**BSPTCL may update.**

## **II. Ranchi Islanding Scheme:**

In the special meeting held on 06.08.2021, it was decided that Ranchi islanding scheme would be formed with one unit of Tenughat TPS (150-160 MW average generation) & Inland IPP (50-55 MW average generation) as participating generator & essential/critical loads of Ranchi to the tune of 180 MW. The islanding frequency & logic will be finalized based on the result of dynamic study to be carried out by SLDC Jharkhand/ERLDC.

The following timelines were decided:

1. Submission of requisite information by SLDC, Jharkhand: 2nd week of Aug' 2021.
2. Completion of Islanding simulation study by ERLDC: 4th Week of Aug' 2021
3. Review of islanding study & designing of the logic: By September'2021
4. Implementation & Operationalization of the Islanding Schemes: By February'2022

In 106<sup>th</sup> PCC meeting held on 16.09.2021 it was informed that the requisite information had already been shared by SLDC Jharkhand and the study is under progress by ERLDC. Further SLDC Jharkhand was advised to prepare the DPR by September'2021 for PSDF funding, if required.

In the 44<sup>th</sup> TCC Meeting, JUSNL updated that preparation of DPR for PSDF funding is under process and the same would be completed within 15 days.

TCC stressed on the fact that this issue is being regularly monitored by MoP and advised JUSNL for timely implementation of the Islanding Scheme.

In the 184<sup>th</sup> OCC meeting, JUSNL representative submitted that they had requested for budgetary offer from GE, Siemens and ABB and after getting the same they would prepare the DPR.

OCC advised JUSNL to expedite the work and prepare the DPR within the stipulated time frame.

In the 185<sup>th</sup> OCC meeting, JUSNL informed that the tender for DPR would be opened on 25<sup>th</sup> Nov 2021.

In the 186<sup>th</sup> OCC meeting, JUSNL representative informed that the tender had been finalized and the DPR would be placed by 5<sup>th</sup> Jan 2022.

OCC advised JUSNL to inform ERPC once DPR gets submitted.

**JUSNL may update on the DPR submission status and further progress.**

**In addition to above new islanding schemes, the following schemes have already been finalized and under different stage of implementation:**

### **III. Chandrapura Islanding Scheme:**

The scheme detail in brief is as follows:

- The CTPS-B islanding scheme is to be designed with two units of CTPS-B (2x250 MW) generating station as participating generator and connected loads at CTPS, Putki, Biada, Nimiaghata & Patherdih. The estimated off-peak and peak load in the proposed islanding system is 280 MW & 420 MW respectively.
- The islanding frequency for CTPS-B islanding system was decided as 48.4 Hz.

In special meeting held on 06.08.2021, following deliberations took place: Representative of SPE wing of DVC updated that necessary discussion for implementation of the scheme at CTPS-B is going on with M/s GE for finalization of the scope of work & other modalities. He submitted that the tender process for implementation of islanding scheme would be initiated within two weeks.

In the 44<sup>th</sup> TCC Meeting, DVC representative informed that the work order for implementation of Chandrapura Islanding Scheme would be placed by March-2022 and the same would be implemented within 6 months.

In the 184<sup>th</sup> OCC meeting, DVC representative submitted that the scope of work has already been finalized but the budgetary offer is yet to be received from GE & Siemens. He further intimated that after getting necessary details from GE and Siemens, approval from their appropriate authority would be taken.

On query, he submitted that they are following up the matter with Siemens and GE on daily basis and stated that they would resolve the issue within one week.

OCC advised DVC to update the status to ERPC and ERLDC.

In the 185<sup>th</sup> OCC meeting, DVC representative informed that the scope of work and scheme for the islanding of CTPS unit # 7 & 8 has been prepared and the budgetary offer from M/s Siemens & M/s GE has also been collected. The scheme would be finalized within 2-3 months and subsequently the tendering process would be initiated.

OCC advised DVC to complete the work within the stipulated time period.

In the 186<sup>th</sup> OCC meeting, DVC representative informed that the project is in the process of approval and the NIT would be floated within a month.

**DVC may update.**

### **IV. KBUNL Islanding Scheme:**

In special meeting held on 08.06.2021, following deliberations were made:

1. KBUNL Islanding scheme would be designed considering both units of KBUNL stage-II
2. (2x195 MW) as participating generator and connected radial loads at Gopalganj along with in-house load of KBUNL.



3. The islanding frequency will be at 48.6 Hz and this is subject to revision based on the suggestion received from KBUNL/OEM on under frequency settings of the generator units.

4. KBUNL would expedite the construction work related to implementation of Islanding scheme in switchyard. They would also take up with concerned OEM for testing and commissioning of islanding relay panel at their end.

In 106<sup>th</sup> PCC Meeting following deliberations were took place -

Regarding bay construction work at KBUNL switchyard, NTPC informed that civil work would be completed by October-21 & further testing & commissioning would be completed by January-21.

ERPC secretariat informed that time line for implementation of KBUNL islanding scheme had been decided as December-21 and advised NTPC to complete the bay construction work as well as other pending works related to implementation of the islanding scheme at the earliest.

In the 44<sup>th</sup> TCC Meeting, NTPC representative informed that the Islanding Scheme would be implemented by February-2022.

TCC advised NTPC representative to share the detailed timelines for completion of the remaining work to ERPC.

TCC further advised NTPC to implement the KBUNL Islanding Scheme as per the timeline.

In the 184<sup>th</sup> OCC meeting, KBUNL representative submitted that 4 nos. of bays are under erection, however, the civil work for construction of Bus-sectionalizer is under progress and after completion of the same erection work would be started.

Further, KBUNL representative expressed that the islanding frequency i.e., 48.4Hz, as proposed by ERLDC, needs to be reviewed as they have their low frequency tripping command at 48.5Hz. ERLDC representative advised KBUNL to consult with their OEM and OS and thereafter getting the inputs from OEM and OS the matter may be further discussed for finalization of the frequency.

In the 185<sup>th</sup> OCC meeting, KBUNL representative informed that the matter of islanding frequency has been taken up with their OS & OEM. Further, a meeting with ERLDC was also held wherein some issues were highlighted. After the receipt of final simulation study from ERLDC, the approval from their OS & OEM would be taken.

ERLDC submitted that KBUNL is a unit of less capacity (less than 200MW) and does not have either RGMO or FGMO mode of frequency response. Further, without any mode of governor response it is very difficult for the Islanding scheme to sustain. KBUNL has some mechanical form of governor response for which detailed modeling is not possible at ERLDC side. In view of the above ERLDC suggested KBUNL to carry out the simulation study through some other agencies.

On query, KBUNL representative informed that the bus sectionalizer bay is still under the process of erection because of hamper in civil works due to heavy rainfall. The work has been started since 1<sup>st</sup> Nov 2021 and would be completed in another 3-4 months.

In the 186<sup>th</sup> OCC meeting, KBUNL representative informed that the details of simulation study for the Islanding Scheme have been received from ERLDC, wherein they have been advised to incorporate some changes in the under-frequency settings for the successful implementation of the Islanding Scheme. He further informed that, in order to take up the matter with their OS &



OEM, some documentary confirmation from ERLDC side would be required.

OCC advised KBUNL to bilaterally resolve the issue with ERLDC at the earliest.

Regarding bay construction work at KBUNL, it was informed that the bus sectionalizer erection work is under progress and would be completed in another 3-4 months.

OCC expressed serious concern over the issue and advised KBUNL to complete the erection, commissioning & testing works by the end of March 2022.

**KBUNL may update.**

**V. IB-TPS Islanding Scheme:**

The scheme was finalized in the special Meeting on Islanding Scheme of IB-TPS held at ERPC, Kolkata on 12th December 2018.

In special meeting held on 06.08.2021, OPGC representative informed that work order had been placed on OEM (M/s BHEL) for implementation of the Islanding scheme at IB TPS units.

OPGC was also advised to take up the issue with their highest authority as well as with the OEM for expediting the implementation of islanding scheme.

In the 44<sup>th</sup> TCC Meeting, OPGC representative informed that IB TPS Islanding Scheme would be implemented as per the given timeline i.e., April-22.

In the 184<sup>th</sup> OCC meeting, OPGC representative informed that the erection and testing work has been completed. He further submitted that the islanding scheme would be implemented after consultation with OPTCL regarding the load details (144 MW).

OCC advised OPGC to update the status of their meeting with OPTCL regarding this to ERPC and ERLDC.

In the 185<sup>th</sup> OCC meeting, OPGC representative submitted that a meeting with OPTCL has been conducted on 11.11.2021 regarding erection and commissioning of DTPC at OPGC and Tarkera ends. The work has already been started at the Tarkera end and the whole work is scheduled to be completed by the end of December 2021.

OCC advised OPGC to complete the commissioning work of DTPC coupler at the earliest.

In the 186<sup>th</sup> OCC meeting, OPTCL representative informed that the installation and commissioning work of DTPC at both Budhipadar and IB TPS end are in progress and would be completed shortly. Further, co-ordination with M/s ABB regarding the commissioning work had also been done and the work is expected to be completed by the end of January 2022.

**OPTCL may update.**

**B4.2. Separate Display of Islanding Schemes (IS) on SCADA of respective states LDCs/Sub SLDs and RLDCs**

Hon'ble Minister for Power and New & Renewable Energy had taken a meeting to review the Islanding Schemes in Indian Power system on 28<sup>th</sup> December 2020. Further, on 19<sup>th</sup> August 2021

Secretary, Ministry of Power had taken another meeting (MoM enclosed) in this regard wherein it was decided that for real time monitoring of participating generators & critical loads of Islanding schemes, a separate display of Islanding Schemes on SCADA of respective states LDCs/Sub SLDCs and RLDCs may be prepared. Delhi SLDC and NAPS IS had already prepared the display page on their SCADA.

Separate displays of the Islanding Schemes on SCADA may be set up in the SLDCs/Sub SLDCs and RLDCs.

In the 184<sup>th</sup> OCC meeting, OCC advised all the concerned state SLDCs to set up a separate SCADA display at their control room end so that the same can be extended to ERLDC. The display needs to be set up for both the existing and the proposed Islanding schemes.

OCC advised ERLDC SCADA representative to co-ordinate with the concerned utilities regarding the same.

In the 185<sup>th</sup> OCC meeting, ERLDC SCADA team informed that separate display for CESC islanding scheme has already been prepared. Necessary details of Farakka islanding scheme have also been received. Upon receipt of details from other concerned utilities, the separate display of SCADA for the respective islanding schemes would be set up.

OCC advised ERLDC SCADA team to implement the displays for the islanding schemes by December'2021.

In the 186<sup>th</sup> OCC meeting, ERLDC representative informed that the SCADA display of Farakka Islanding Scheme had been implemented on ERLDC side.

He further informed that, the Bandel and Haldia Islanding Scheme displays would be completed by the end of December 2021. For the Bakreshwar Islanding scheme display, some clarifications are required and update regarding its implementation would be shared in upcoming OCC meeting.

It was further deliberated that the displays of the Islanding Schemes had to be implemented on the SLDC level which would be further extended to the ERLDC level.

SLDC West Bengal representative informed that the implementation of Islanding Scheme displays had already been completed for Bandel, Bakreshwar and Tata Power. The same for CESC is also in process and would be completed shortly.

**ERLDC may update.**

**ITEM NO. B.5: Reliable Power Supply to Lalmatia/Godda/Dumka areas of JUSNL**

**B5.1. Restoration of 220kV Farraka-Lalmatia S/C line**

The 220 kV Farakka-Lalmatia S/C was out of service since April 2021 due to tower collapse. The 220/132/33 kV Lalmatia substation is relying on only 132 kV lines. At present the local load at 220 kV Dumka and Godda S/S were being radially fed from 400/220 kV Maithon S/S through 220 kV Maithon-Dumka D/C and 220 kV Dumka-Godda D/C.

In 181<sup>st</sup> OCC Meeting, JUSNL representative submitted that they had got a letter from NTPC on

19<sup>th</sup> July '21 regarding anti-theft charging of the 220kV Farraka-Lalmatia S/C line at 33kV level. Earlier the anti-theft charging of the line was done at 11kV level but incidents of thefts have been reported in some portion of the conductor.

Further, Jharkhand representative requested NTPC to submit the details of the 33kV lines passing below 220kV Farakka-Lamatia T/L. He added that as per information obtained from their JUSNL Discom part, the 33kV lines are mostly connected with 11kV feeders and due to this it would be difficult to charge the Farakka-Lalmatia line at 33kV level in Pakur area.

NTPC representative informed that they had charged the line up to loc no.241 but in between loc no.76-82 only the top conductor was in charged condition and the bottom rest were not; because of this theft might have happened in that portion. He further added that they had already isolated the section from loc no.76-82, whereas up to loc no.76 the line is in charged Condition and from loc no.82-241 the line needs to be charged.

ERPC advised NTPC and Jharkhand to explore the possibility of anti-theft charging at 33kV level first and if that is not feasible then charging at 11kV can be assessed.

In the meeting held on 10<sup>th</sup> August 2021 by the Hon'ble Secretary, Ministry of Power, Government of India, ECL was directed to handover the FLTS assets on "as is where is basis" to

JUSNL, the Operation and Maintenance whereof as was with the NTPC is also to be transferred to the JUSNL without any further delay and latest by 20<sup>th</sup> August 2021. Further JUSNL was directed to comply with all other directions of the CERC's order dated 21.07.2020, after the transfer of the FLTS from ECL.

In the 182<sup>nd</sup> OCC meeting, JUSNL representative submitted that the tripartite agreement for taking over of FLTS as well as O&M of FLTS is in process and the same would be done after getting the consent from the competent authority by 4<sup>th</sup> week of August'2021.

OCC advised JUSNL to expedite the work for anti-theft charging without any further delay. JUSNL representative ensured to do the same.

ERLDC representative advised JUSNL for putting 220kV Lamatia-Godda line into service. JUSNL representative informed that they had tried to charge the line once but due to voltage rise at Lalmatia end, they had to open the line.

OCC advised JUSNL to re-check the possibility of charging the 220kV Lamatia-Godda line for reliable power supply to Lalmatia.

ERLDC representative opined that restoration of the 10 nos. of collapsed towers may be done first on priority basis.

JUSNL representative stated that the estimate for restoration of the lines has already been approved by their BoD and Govt. of Jharkhand has been approached for fund requisition. In the meantime, the tendering process would be finalized and after getting the necessary fund approval the work order for the same would be placed.

On query, JUSNL representative ensured that the line would be restored by June'22.

In the 185<sup>th</sup> OCC meeting, JUSNL representative informed that fund requisition to their energy department has been requested on 8<sup>th</sup> Nov 2021 and the work would be started upon receipt of funds.

It was highlighted by OCC that restoration of the line to be taken on priority basis, since it serves commercial interest of Jharkhand by drawing power directly from Farakka STPS. Besides, restoration of the line would also improve reliability of power supply.

In the 186<sup>th</sup> OCC meeting, JUSNL representative informed that a query regarding the proposal had been received from their Energy Department and the reply for the same had already been given. The work would be started after the receipt of funds from their Energy Department.

**JUSNL may update the progress of restoration of Farakka-Lalmatia 220KV S/C line.**

#### **B5.2. Commissioning of 220kV Tenughat-Govindpur line**

In 179<sup>th</sup> OCC meeting, ERLDC representative stressed over the fact that commissioning of 220kV Tenughat-Govindpur line would increase the system reliability and the said line may be commissioned at the earliest.

In 181<sup>st</sup> OCC Meeting, Jharkhand representative submitted that as per the information received from Powergrid the line would be ready by July'21 end and it would take another 15 days for getting the necessary Statutory Clearance.

OCC advised Jharkhand to apply for the necessary Statutory Clearance in the meanwhile so that further delay can be avoided when the line gets ready. OCC advised Jharkhand to co-ordinate with Powergrid and get the said line ready by 15<sup>th</sup> August 21.

In the 182<sup>nd</sup> OCC meeting, JUSNL representative submitted that they had already got all the Statutory Clearance. He further added that only one railway crossing is pending which is expected to be completed by 10<sup>th</sup> Sept'21.

In the 183<sup>rd</sup> OCC meeting, JUSNL representative submitted that all pending work has been completed and final checking of the line is under progress.

They intimated that the line would be charged by first week of Oct'21.

In the 184<sup>th</sup> OCC meeting, JUSNL representative submitted that the line would be charged by 26.10.2021.

In the 185<sup>th</sup> OCC meeting, JUSNL representative informed that one circuit has been commissioned on 3<sup>rd</sup> Nov 2021. Because of some breaker issues in the second circuit the commissioning is yet to be done. He further added that the commissioning would be done by 10<sup>th</sup> December'2021.

In the 186<sup>th</sup> OCC meeting, JUSNL representative informed that the work would be completed by the end of December 2021.

OCC advised JUSNL to expedite the work at the earliest.

**JUSNL may update the status of completion of work.**

### **B5.3. Status of O & M agreement with Powergrid for bay equipment at Maithon end and resolution of auto recloser issues in the 220 kV Maithon-Dumka Lines**

In 103<sup>rd</sup> PCC meeting, during discussion of tripping of 220 kV Maithon-Dumka line-2 on 15/05/21, it was informed that the auto-recloser in the said line is not in operation due to some issues in PLCC. It was also come to notice that there was no formal agreement between JUSNL & Powergrid for O & M of the bay equipment at Maithon end. As a result, bay equipment at Maithon end for 220 kV Maithon-Dumka D/C lines are not being maintained properly.

In 181<sup>st</sup> OCC Meeting, Jharkhand representative submitted that some queries along with few finance observations had been raised to Powergrid in this regard. However, complete reply from Powergrid side is yet to be received and as soon as they receive the response from Powergrid, they would proceed for the agreement. However, in principle they are ready for the agreement.

ERPC opined that as Farakka-Lalmatia line is not in service at present, Maithon-Dumka line is of vital importance and healthiness of PLCC at both ends is to be ensured.

OCC advised Jharkhand to take up the necessary rectification work for ensuring the healthiness of the PLCC. In this regard, Powergrid has also given consent to Jharkhand for the necessary PLCC work at Maithon end.

Jharkhand representative assured that the PLCC would be restored by 15<sup>th</sup> August 21.

In the 182<sup>nd</sup> OCC meeting, JUSNL representative submitted that Powergrid had submitted the revised estimate and the same is in the process for approval by competent authority. He further informed that it would be completed by 1<sup>st</sup> week of September'2021.

In the 183<sup>rd</sup> OCC meeting, JUSNL representative intimated that in-principle approval for the O & M agreement had already been accorded to Powergrid. Further, signing of the agreement would be completed by September'21.

In the 184<sup>th</sup> OCC meeting, JUSNL representative submitted that the agreement would be signed after getting necessary approval from their Finance wing.

In the 185<sup>th</sup> OCC meeting, JUSNL representative informed that approval has been received from their finance department on 22.11.2021 and the agreement would be signed by 10<sup>th</sup> December 2021.

In the 186<sup>th</sup> OCC meeting, JUSNL representative informed that the agreement had already been signed on 1<sup>st</sup> December 2021.

**JUSNL may update about the status of O&M agreement.**

#### **ITEM NO. B.6: Restoration of PLCC for 220 kV Chandil-STPS S/C line**

In 101<sup>st</sup> PCC meeting held on 13.04.2021, it was come to notice that both the channels of PLCC of 220 kV Chandil-Santaldih S/C line is unhealthy at Chandil end since May-2020. PCC advised JUSNL to rectify the PLCC issue at Chandil end at the earliest.

In 108<sup>th</sup> PCC meeting held on 16.11.2021, JUSNL representative informed that the PLCC

rectification work could not be carried out as they are yet to receive the financial approval for the said work from their higher authority.

220 kV Chandil-STPS being an inter-state line and connected to generating station, healthiness of PLCC/line shall be ensured for overall reliability & security of the grid.

In the 185<sup>th</sup> OCC meeting, OCC expressed serious concern over the issue and advised JUSNL to update the status at the earliest.

In the 186<sup>th</sup> OCC meeting, JUSNL representative informed that the technical part of the tender has been opened and PLCC rectification work would be carried out after finalization of the tender.

**JUSNL may update.**

**ITEM NO. B.7: Outage of Important Transmission System.**

**B7.1. 132kV Sagbari–Melli.**

Sikkim vide mail dated 09.06.2021 updated the following status:

- 1) In loc 82,83 & 84 we have low ground clearance which need hill cutting but if needed TL can be charged after putting temporarily barbed wire fencing.
- 2) In loc 98-99 a house had been constructed just below the line and warning had been issued to the owner for not to do vertical extension of the house till any such arrangement is made.
- 3) In loc 116 &117 land owner demanding for intermediate tower and not allowing for us to clear the jungles.
- 4) Loc 128 is in dilapidated condition due to sinking effect posing threat to lives and properties. Local public are asking to shift the tower in safe place before restoration of supply in the TL.
- 5) 80% of jungle clearance has been completed and remaining 20% is in Forest area most of it is under west district and waiting for permission from Forest department.
- 6) The delay in obtaining permission for following trees in forest land is that it cannot be ascertained whether FCA clearance during construction of TL was obtained as the record is not available either in power department or in DFO Office. Regarding this it had been told by ERPC that once obtaining environment clearance at the time of construction there need not to take permission for further clearance of ROW from Forest dept and this matter is been conveyed to the Forest department but they informed us as per Forest Act of Sikkim state permission has to be obtained for fresh felling with payment of compensation. File for approval is being send to conservator of Forest from DFO on 10/6/2021.

In the 181<sup>st</sup> OCC meeting, Sikkim representative submitted that for the rest 20% work, they are yet to get clearance from the Forest Department. He further informed that there are also some RoW issues in that portion of the line. Further, ERLDC representative stressed over the fact that being a very important line, the restoration of the 132kV Sagbari–Melli linemay be done at the earliest.

OCC advised Sikkim to take up the matter with Forest Department for obtaining necessary clearance and also to resolve the ROW issues without any further delay.

In the 182<sup>nd</sup> OCC meeting, Sikkim informed that the matter is under persuasion.

In the 184<sup>th</sup> OCC meeting, the agenda could not be discussed as Sikkim representative was not available in the meeting.

In the 185<sup>th</sup> OCC meeting, Sikkim representative was not available in the meeting.

In the 186<sup>th</sup> OCC meeting, Sikkim representative was not present during the discussion.

**Sikkim may update.**

## **B7.2. 220kV Pandiabili - Samangara D/C**

220kV Pandiabili-Samangara D/C line tripped on 03-02-2019 during the event of Fani due to Tower collapse. 48 no towers got fully damaged and 12 no towers got partially damaged. Presently the line is charged from Pandiabili end up to location no 58. It is a very important line for supplying power to Puri area. The line is under outage more than 2 years.

In the 182<sup>nd</sup> OCC meeting, OPTCL representative submitted that the restoration work for 220kV Pandiabili - Samangara D/C line has been assigned to Powergrid. He further added that redesigning of tower in view of change of wind zone from Zone 4 to Zone 6 has also been taken up by Powergrid.

On query, OPTCL representative informed that the line is expected to be restored by March'2022.

ERLDC representative expressed that as 220kV Pandiabili - Samangara D/C line is of utmost important; thus, the restoration of the said line may be expedited.

OCC advised OPTCL to expedite the work and also advised OPTCL to submit the work schedule mentioning the timelines for completion of designing, procurement and erection activities to ERPC and ERLDC.

In the 183<sup>rd</sup> OCC meeting, OPTCL representative informed that design of all the tower foundations of subjected line has been changed from open cast to pile foundation-based tower. Therefore, the restoration of the line would take considerable time. He submitted that restoration of the line is expected by June'23.

In the 184<sup>th</sup> OCC meeting, OPTCL representative submitted that the restoration work has been undertaken by Powergrid.

He added that DA & DD type tower design has already been tested and passed by CPRI, however, the prototypes of DB & DC type tower are under testing. Once the testing of the same is successfully completed, the action plan of the restoration work would be submitted by Powergrid.

OCC advised OPTCL to share the action plan to ERPC & ERLDC.

In the 185<sup>th</sup> OCC meeting, OPTCL representative informed that permission for testing of type DB & DC towers has been taken from CPRI but the tentative timelines for completion of test are yet to be received from CPRI.

In the 186<sup>th</sup> OCC meeting, OPTCL representative informed that the type testing of DB & DC towers is under progress at CPRI. Type testing of DB & DC type tower is expected to be completed by 22<sup>nd</sup> and 28<sup>th</sup> December 2021 respectively. Further, the foundation work of towers has also started and is under progress.

**OPTCL may update the status of restoration work.**



### **B7.3. 440/220kV 315 MVA ICT 2 at Meramundali:**

400KV/220KV 315 MVA ICT 2 at Meramundali tripped on 21-02-2021 due to fire hazard at Meramundali SS. The ICT is under outage since then. Meramundali S/S is serving the important load of the Odisha. Long outage of an ICT at such crucial S/S may hamper the reliability of the Grid.

In the 182<sup>nd</sup> OCC meeting, OPTCL representative submitted that the old ICT, which was completely damaged, would be replaced by a new one. The new 315 MVA ICT of BHEL make has already arrived at site and the foundation modification work is going on. OPTCL representative stated that the replacement work is expected to be completed by 30th Nov'21.

OCC advised OPTCL to expedite the work and also to share the work schedule of the same to ERPC & ERLDC for effective monitoring of the same.

In the 183<sup>rd</sup> OCC meeting, OPTCL representative submitted that the foundation work has been completed and the remaining work is expected to be completed by Nov'21.

In the 184<sup>th</sup> OCC meeting, OPTCL representative submitted that the work would be completed by December'21. He further mentioned that representative of BHEL (OEM) is yet to visit the site, however, the civil construction work has been completed and the said transformer is on the plinth.

OCC advised OPTCL to expedite the work and complete it by 31<sup>st</sup> Dec'21.

In the 185<sup>th</sup> OCC meeting, OPTCL representative informed that they are in constant touch with the OEM and after receipt of some of the materials at the site the erection work is expected to be completed by the end of December 2021.

OCC advised OPTCL to expedite the matter with the OEM and complete the work at the earliest.

In the 186<sup>th</sup> OCC meeting, OPTCL representative informed that some materials are yet to be received for which the order has already been placed. After receipt of materials and arrival of OEM representatives, work would be started and would be completed in another 2 months.

OCC advised OPTCL to co-ordinate with their OEM and complete the work without any further delay.

**OPTCL may update the progress of work.**

### **B7.4. Outage of 400kV Main Bus-2 at Dikchu HEP.**

400kV Main Bus-2 at Dikchu HEP has been out since 05.05.2021.

In the 185<sup>th</sup> OCC meeting, Dikchu representative was not available in the meeting.

Dikchu vide mail dated 27.11.2021 informed that, on 07.09.2021 a test had been conducted by them to pin point the fault location. Subsequently, the fault was found in the B phase Circuit Breaker Compartment of 400 KV Dikchu-Teesta 3-line bay 403.

So as suggested by the OEM, there was a need to replace the CB compartment.

In this regard, the offer for new CB compartment from OEM GE(T&D) had already been received on 15<sup>th</sup> Nov' 21. The procurement process is in progress & the works are being planned to be carried out in 3rd week of Jan' 22.

In the 186<sup>th</sup> OCC meeting, Dikchu representative informed that OEM M/s GE had given a lead time of 8 months for the supply of new CB compartment, but considering the seriousness of the issue, M/s GE has now agreed to provide the same in 3 months. The work is expected to be completed by the end of March 2022.

Considering the importance of Dikchu-Teesta-III line, OCC advised Dikchu to expedite the work at the earliest in consultation with their OEM.

**Dikchu HEP may update.**

#### **B7.5. Prolonged outage of Bus-2 at Rangit HEP.**

During providing shutdown of different elements around Rangit complex, ERLDC came to know that one bus of Rangit (Bus-2) is out since long. Such prolonged outage of one bus at important ISGS power station is an issue of concern for grid security. NHPC is requested to provide the details of outage and restoration plan for same.

In the 186<sup>th</sup> OCC meeting, it was deliberated that separate communication shall be done with NHPC regarding this issue.

**NHPC may update.**

**ITEM NO. B.8: Inadequate reactive power absorption by Sagardighi units resulting in high voltage in pocket leading to payment of high voltage VAR charges by West Bengal.**

Sagardighi is a major generating plant in West Bengal having a total capacity of 1600 MW. However, it has been observed that Sagardighi is not absorbing reactive power up to its capability, which in turn results in high voltage in and around Durgapur/Sagardighi. This may be noted especially at the backdrop of West Bengal paying high reactive due to such injection of VAR at high voltage.

Even one ckt. of Durgapur-Sagardighi also opened on number of occasions to control the overvoltage.

Reactive performance of Units at Sagardighi is as follows:

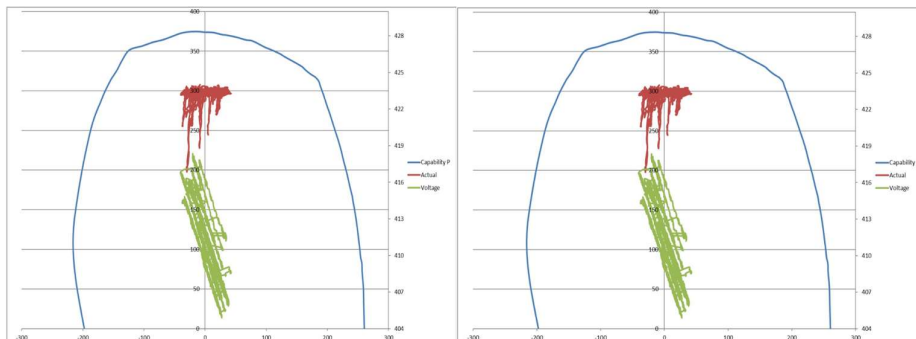

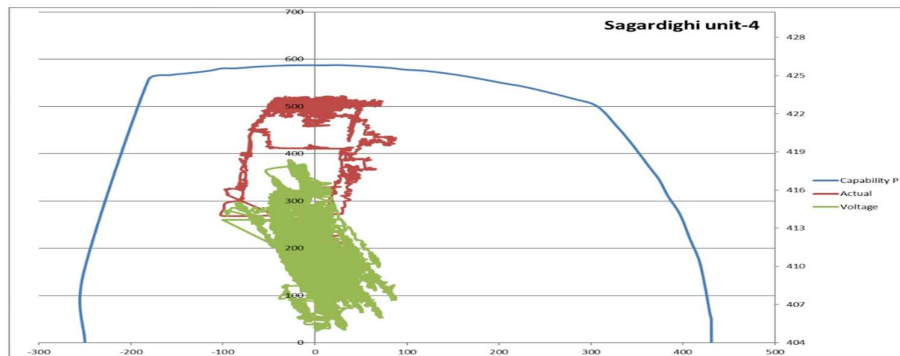

- It can be seen in above capability curve that reactive power absorption was very minimum for most of the time, even when volage was more than 420 kV on multiple occasions.
- 500 MW units can absorb almost 150 MVar more while 300 MW can absorb 100 MVar more reactive power
- Fault MVA of Sagardighi is approximately 30000 MVA. So, if each unit contributes 100 MVar absorption and stop injecting then in total 400 Mvar relief will be there and Sagardighi bus voltage is expected to reduce by 6 KV.

#### GT TAP OPTIMIZATION:

- It was later communicated that at LV side Sagardighi is facing low voltage and is not able to absorb Mvar further.
- As per information received present GT tap is 03 at Sagardighi which corresponds to 21/420 kV. So, GT tap may be increased to reduce the HV side voltage.

**WBPDCL may update.**

**ITEM NO. B.9: Shifting/Re-routing of transmission line tower located in campus of Mahabodhi Convention Centre, Bodhgaya.**

132KV Barhi-Biharsharif T/L is crossing in the construction area of under construction cultural center. This line is under the jurisdiction of DVC (132 kv Barhi DVC sub-station). Tower no. 1 to 246 is under the jurisdiction of DVC, whereas tower no. 21 to 189 are under jurisdiction of BSPTCL.

Tower location 227 to 229 is located in campus of under construction Mahabodhi cultural center, Bodhgaya and location no. 228 is exist in center of campus. Type of tower has been constructed at approx. 13-meter distance from center of corridor of this line.

Considering the large gathering of people here in future this shifting/re-routing work needs to be done on priority basis due to safety concerns.

**DVC is requested to submit a plan for above work at the earliest.**

**ITEM NO. B.10: Agenda by OPTCL**

#### **B.10.1. Splitting of Budhipadar 220kV Bus due to high fault level.**

OPTCL vide mail dated 30.08.2021 submitted that the fault level at Budhipadar 220 kV bus during steady state is 42.79 kA which is beyond the breaker rating of 40 kA. OPTCL has conducted the system study and the study reveals that in the base case the fault level is 42.79 kA

while during splitting the fault level at the two buses are 30.40kA and 12.72kA. ERPC may advise suitable scenario to mitigate the fault level at Budhipadar.

In the 183<sup>rd</sup> OCC meeting, OPTCL informed that the fault level at 220 kV Budhipadar S/s is found to be crossed more than 42 kA and there are multiple generating units connected to 220 kV buses. In order to reduce the fault level, they proposed to segregate the 220 kV bus & connected feeders by opening the bus coupler breaker. In this regard they had carried out a study.

ERLDC pointed out that the proposal of segregating the bus by opening of bus coupler breaker reduces the overall reliability of the system.

OPGC informed that in the given study all four evacuating lines from IB TPS is connected to same bus at Budhipadar thereby affecting the reliability of the evacuation of IB TPS generation in case of any bus fault at Budhipadar.

ERPC secretariat informed that as per the decision taken in the special meeting on “implementation of SPS at Budhipadar S/s” the 220 kV Vedanta-Budhipadar D/C is to be made off after commissioning of second 220/132 kV ATR at Budhipadar and as such Vedanta injection at Budhipadar shall not be considered in the study. Further on suggestion of proper bus split at Budhipadar by bus-sectionalizer, OPTCL submitted that it would take considerable time to implement the proper bus splitting scheme.

After detailed deliberation, OCC advised OPTCL to carry out revised study in consultation with OPGC & SLDC Odisha for different scenarios and submit the report to ERPC/ERLDC for further discussion in this regard.

#### **B.10.2. Splitting of Meramundali 220 kV Bus due to high fault level.**

OPTCL vide mail dated 15.09.2021 submitted that the fault level at Meramundali 220 kV bus during steady state is 40.89 kA which is beyond the breaker rating of 40 kA. OPTCL has already conducted the system study. However, ERPC may advise suitable scenario to mitigate the fault level at Meramundali.

In the 183<sup>rd</sup> OCC meeting, after detailed deliberation, OCC advised OPTCL to carry out revised study in consultation with OPGC & SLDC Odisha for different scenarios and submit the report to ERPC/ERLDC for further discussion in this regard

In the 184<sup>th</sup> OCC meeting, OPTCL representative submitted that due to the ongoing festive month, meeting with OPGC and SLDC Odisha could not be convened. He further intimated that a meeting would be convened by 1<sup>st</sup> week of November 2021 and the outcome of the meeting would be shared with ERPC & ERLDC.

In the 185<sup>th</sup> OCC meeting, OPTCL representative informed that the meeting with OPGC & SLDC Odisha is yet to be convened and is scheduled to be held by the end of November 2021. He further stressed on the fact that if all the four lines are connected to the same bus the issue of power evacuation through IB TPS generation would persist. Therefore, in order to balance the load and generation the bus coupler is kept in open condition. He further submitted that the 2<sup>nd</sup> auto transformer is at the final stage of erection at Budhipadar S/s and after commissioning of the same, a joint discussion may be carried out to discuss the matter of bus splitting.

ERLDC representative mentioned that opening the bus coupler to reduce the fault level critically hampers the reliability aspect and OPTCL along with its beneficiaries may discuss upon formulating suitable plans like installation of bus sectionalizer, up gradation of circuit breakers,

bus augmentation, etc. for the implementation of bus splitting scheme.

OCC opined that the fault level at Budhipadar is very high and action has to be taken to reduce the same. OCC further advised OPTCL to convene a joint meeting along with its beneficiaries to explore the possibilities of finding a permanent solution to the above problem.

In the 186<sup>th</sup> OCC meeting, OPTCL representative informed that the meeting would be convened after commissioning of the second auto transformer.

OCC advised OPTCL to convene the meeting with concerned parties at the earliest to work out a permanent solution for the problem.

**OPTCL may update.**

**ITEM NO. B.11: Event of Smelter Load tripping at Sterlite CPP on 20<sup>th</sup> & 28<sup>th</sup>  
September 2021**

Smelter load tripping of 400 kV Sterlite CPP was observed on two occasions i.e., on 20 & 28<sup>th</sup> September 2021 due to electrical disturbance in the downstream side which resulted into Smelter load reduction of more than 1000 MW.

- This has caused under drawl of Odisha by more than 1000 MW. Subsequently with SPS action at Sterlite, injection to grid was limited up to 800 MW.
- Intimation of such events is necessary in real time as grid flow pattern gets affected considerably and also this is important for frequency response assessment purpose.

Report by ERLDC is attached at **Annexure-B11**.

In the 184<sup>th</sup> OCC meeting, ERLDC representative submitted that due to the Smelter load tripping at Sterlite CPP, there was huge under drawl on that day. Odisha tried to mitigate the problem by reducing their hydro but the under drawl persisted for more than one hour.

Odisha representative mentioned that they had taken remedial actions like reducing the hydrogeneration but still the issue of under drawl persisted. He further added that the matter would be discussed with their higher authority and the details of the same would be shared with ERPC and ERLDC by 10<sup>th</sup> November'21.

OCC advised Odisha to send their action plan regarding mitigating the above-mentioned issue so that it can be discussed further in next OCC.

In the 185<sup>th</sup> OCC meeting, SLDC Odisha representative informed that a meeting with OPTCL would be convened to discuss the issue and based on the discussion of the meeting; necessary action plan regarding the issue would be shared to ERPC/ERLDC.

OCC advised SLDC Odisha to take up the matter with OPTCL at the earliest and send the detailed report so that it can be discussed in the upcoming OCC meeting.

In the 186<sup>th</sup> OCC meeting, OCC advised SLDC Odisha to send the detailed report to ERPC so that it could be discussed in the upcoming OCC meeting.

**SLDC Odisha may update.**

**ITEM NO. B.12: Technical overview of AMR Data Center hardware and application refreshment program for Eastern Region**

AMR Hardware and Software/ Application installed and running since 2013 at ERLDC for all the constituents of ER. All the Hardware equipment installed in the system has already elapsed almost 08 Years and being IT equipment, as per present CERC regulation already usable life is consumed.

Accordingly for running the system smoothly, with latest Cyber security aspects/compliances, both, Hardware and Software refreshment is required. New Hardware will be installed as per the CEA/CERC guideline for IT Network equipment along with New AMR application will be developed, with latest JAVA version and new features.

In view of above, M/S. TCS shall deliver a presentation on above for better understanding. Further, after finalization of technical aspects/features, necessary commercial offer shall be submitted.

In the 184<sup>th</sup> OCC meeting, Powergrid representative submitted that AMR Hardware and Software/ Application which have been running since 2013 at ERLDC for all the constituents of ER became old and have already consumed its usable life. He also added that as per CERC guidelines regarding Cyber security aspects/compliances both the Hardware & Software need to be updated.

M/s TCS representative gave a brief presentation on the same.

OCC agreed to give go ahead to Powergrid for finalizing the technical aspects so that financial cost assessment can be done. Powergrid representative informed that they would provide the cost estimate for the up-gradation project within 10 days.

Further, OCC advised Powergrid to co-ordinate with ERLDC for finalization of the technical aspects.

In the 185<sup>th</sup> OCC meeting, Powergrid representative informed that after having several meetings with M/s TCS a preliminary offer for both software and hardware part has been received amounting to Rs. 1 Crores 14 Lakhs. He added that for the detailed technical study another 1-week time would be required.

In the 186<sup>th</sup> OCC meeting, Powergrid representative informed that the detailed report has been sent to ERLDC.

ERLDC representative informed that the comments would be sent to Powergrid for further deliberation with M/s TCS.

**Powergrid may update.**

**ITEM NO. B.13: Agenda by TPTL.**

With reference to the 185<sup>th</sup> OCC Shutdown meeting dated 18.11.2021 wherein the shutdown of 400 kV D/C Teesta-III – Kishanganj Transmission Line viz. CKT – I (B), CKT -I (C) & CKT -II from 16.12.2021 to 24.12.2021 was approved by ERLDC. The Shutdown is requested by PGCIL ER-II for completing LILO works of 400 kV Teesta III – Kishanganj line at Rangpo substation. Currently in the existing transmission system CKT-I of the transmission line is LILO at Rangpo Sub-station

(current SLD diagram of the Transmission line is attached). As a consequence of LILO of CKT-II of the line, transmission tower(s) 99 to 113 of the 400kV Teesta-III – Kishanganj Transmission line will be rendered inoperative. The said transmission towers were constructed by TPTL after facing huge ROW challenges. Due to non-operation of the encompassing section of the line between these towers, the said section is at risk of theft. The said towers are a part of an important ISTS line of the Eastern Region and shall be kept safeguarded for any future utilization purpose. It is requested that a suitable arrangement may be planned by the nodal authority to keep the section of the line safeguarded from theft.

In the 186<sup>th</sup> OCC meeting, TPTL representative informed that the shutdown of 400 KV D/C Teesta-III – Kishanganj line at Rangpo S/s for LILO works would render the 14 nos. of transmission towers from loc 99 to 113 ineffective thereby increasing the chances of theft. He further stressed upon the fact that, being an asset of worth Rs. 50 crores, utmost care must be taken to safeguard the same. Considering the line to be very short, it could be easily charged in T-connection for anti-theft safeguard.

ERLDC representative informed that TPTL would have to take permission from the appropriate authority for the T-connection.

OCC advised all the associated parties (e.g., Powergrid, TPTL, TUL etc. to explore the possibilities for the provision of charging the section of the unused line by nearby 220 KV/132 KV/66 KV lines. After getting inputs from the concerned parties a special meeting would be convened to further deliberate on this matter.

OCC further opined that regarding permission of T-connection, ERPC would take up the matter with CEA for further clarification in this regard.

In the Special Meeting held on 13.01.2022 Powergrid representative proposed an arrangement for the LILO connection of the 2<sup>nd</sup> circuit of the 400kV Teesta-III – Kishanganj Transmission line. The pictorial representation of the same is attached at **Annexure-B13**. All the members agreed to the proposal.

**Members may note.**

**ITEM NO. B.14: Frequent Grid disturbance in OPTCL's (STU) 220KV network.**

Odisha Power Generation (OPGC) is operating its 2x210 MW units at IB Thermal Power Station, Banharpali, Jharsuguda. The entire capacity has been allocated to GRIDCO. The units have been operating since the year 1994. The electrical power from the plant is being evacuated to OPTCL's 220KV Budhipadar substation at Jharsuguda through OPTCL's 02 nos. 220KV D/C line.

In this reference the grid failure (black out) has happened 3 times this year (2021). The details of the tripping are mentioned below.

| SL No. | TRIP DATE | TRIP TIME | CAUSE OF TRIPPING  |
|--------|-----------|-----------|--|
| 1      | 08-Apr-21 | 14:07     | <ul style="list-style-type: none"> <li>• At our end Distance Protection Zone – 2, Zone – 3 &amp; directional Earth Fault Initiated in all four outgoing lines.</li> <li>• Both Unit-01 &amp; 02 tripped on over frequency protection.</li> </ul> |



|   |           |       |   |
|---|-----------|-------|---|
| 2 | 09-Oct-21 | 11:57 | <ul style="list-style-type: none"> <li>• At our end Directional Earth fault initiated in all three IB-Budhipadar outgoing lines (Lin-01, Line-03 &amp; Line-04). IB-Budhipadar Line-02 tripped on</li> <li>• Distance protection zone-1 (fault loop: L1-N).</li> <li>• Both unit-01 &amp; 02 tripped on over frequency protection.</li> </ul> |
| 3 | 30-Nov-21 | 10:12 | <ul style="list-style-type: none"> <li>• At our end “zone-2 start” &amp; “zone-3 start” initiated in all four IB-Budhipadar outgoing lines (Line-1, Line-2, Line-3 &amp; Line-4).</li> <li>• Both Unit-1 &amp; 2 tripped on “over frequency” protection.</li> </ul>   |

This type of disturbance puts thermal, electrical and mechanical stress on our Power plant equipment which is affecting the reliability of the plant and also the life cycle of the equipment.

In the 186<sup>th</sup> OCC meeting, OPTCL representative informed that some protection issues related to the bus scheme were identified and the matter has already been discussed with M/s Siemens for further deliberation in this regard. From the short-term perspective planning for some hardware related augmentation is going on. Further, replacement of bus conductors is also planned to be implemented in coming months.

ERLDC representative advised OPTCL to implement the bus bar protection scheme.

Regarding blackout at Tarkera end, OPTCL representative informed that any protection related issues or any abnormality in the switchyard could not be identified. However, investigation on the whereabouts of the signal that triggered the tripping command is underway.

**OPTCL may update.**

**ITEM NO. B.15: Issue in smooth transition from ground return mode to metallic return mode during tripping or revival of one pole in +/-500KV Talcher-Kolar HVDC.**

In the recent past during tripping or revival of one pole of +/-500KV Talcher-Kolar HVDC, smooth transition from ground return mode to metallic return mode had failed to take place.

As per the implemented logic, other live pole is supposed to be switched to metallic return mode immediately after tripping of one pole, if there is no fault in the line of tripped pole. The same logic is followed in case of revival of one pole from shutdown of both poles. However, it was observed that there was failure in auto switchover to metallic return from the ground return mode for 3 instances in the last 2 weeks. The event list is as follows:

| Sl. No | Date       | Event                                  |
|--------|------------|--|
| 1      | 09-01-2022 | During revival of pole-1 from shutdown |
| 2      | 07-01-2022 | During availing of shutdown of Pole-1  |
| 3      | 27-12-2022 | During tripping of pole-1              |

+/-500KV Talcher-kolar HVDC is the major evacuation path of 2000MW Talcher-STPS Stage-II generation to SR & one pole of +500kV Talcher-kolar HVDC is able to evacuate only 150MW during ground return mode. It leads to overloading condition in 400KV-Talcher-Meermundali- DC and associated N-1 violation in case of failure of smooth transition which may lead to untoward events such as cascaded tripping and major Grid Disturbance.

**Powergrid may update.**

**ITEM NO. B.16: Delay in change of STATCOM setting at Rourkela.**

STATCOM is dynamic reactive power compensating device. These devices are used for improving steady state performance as well as the dynamic stability of the system. Therefore, based on system condition there may be requirement of changing the setting even in real time other than the normal seasonal revision. However recently when change in STATCOM setting at Rourkela was suggested by ERLDC it took almost 5 days to change. In case of any technical issues being faced while changing the setting leading to inordinate delay, same may be discussed and the commonly agreed setting may be implemented at the earliest.

One example of impact of quick STATCOM setting change is discussed below:

Instruction was given to Kishanganj for changing the STATCOM setting on 5th January when both the 400 kV bus of the Rangpo was under shutdown and Teesta-III and Dikchu was experiencing very high voltage during lean hydro period. From the plot below it can be seen that post STATCOM setting changed voltage of Kishanganj reduced by 3-4 kV and this helped operator in avoiding any O/V tripping and controlling the voltage. In view of the same it is required to comply the operator instruction of STATCOM setting change at the earliest for better system operation.

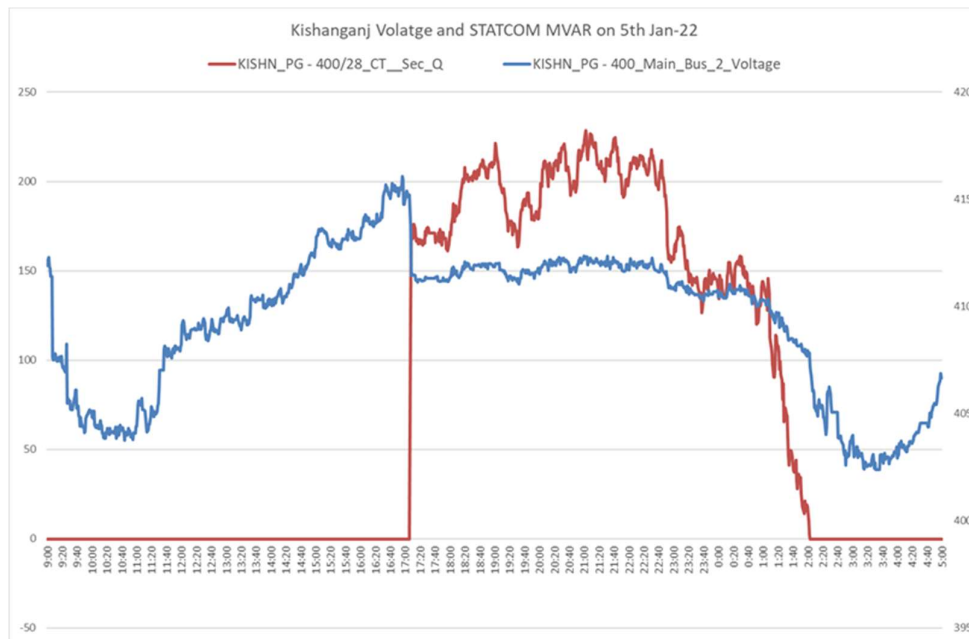

**Powergrid may update.**

**ITEM NO. B.17: Sharing of information regarding change in point of Synchronization of CESC.**

In the recent past it has been observed that CESC shifts its point of synchronization between Kasba to Howrah on multiple occasions. Such information of shifting of point of synchronization may be shared with ERLDC control room on real time basis for better system operation & coordinated operation of regional grid.

**WBSLDC and CSEC may update.**

**ITEM NO. B.18: Finalizing schedule for Mock Black Start, Reactive Power Testing, PSS Tuning and PFR Testing for financial year 2022-23.**

Every year a schedule for mock black start exercise is prepared and finalized before starting of the financial year for monitoring and better coordination. In line with same it is proposed that a schedule for Reactive capability testing, PSS tuning and PFR testing of states units may also be prepared so that same can be monitored.

**Generators may update.**

**ITEM NO. B.19: Draft Central Electricity Authority (Technical Standards for Construction of Electrical Plants and Electric Lines) Regulations-2021**

Central Electricity Authority (CEA) In exercise of the powers conferred under section 177 of the Electricity Act, 2003 had notified "Central Electricity Authority (Technical Standards for Construction of Electrical Plants and Electric Lines) Regulations, 2010" on 20.08.2010 & 07.09.2010 (Hindi version).

Now CEA has proposed to replace the "Central Electricity Authority (Technical Standards for Construction of Electrical Plants and Electric Lines) Regulations, 2010" by a new regulation. Accordingly, the draft new regulation namely "**Draft Central Electricity Authority (Technical Standards for Construction of Electrical Plants and Electric Lines) Regulations, 2021**" is being published for comments/ suggestions/ objections.

The draft regulation is available on CEA Website [www.cea.nic.in](http://www.cea.nic.in). The same is enclosed at **Annexure-B.19**.

The comments/ suggestions/ objections on aforementioned draft regulations may be sent to Chief Engineer (Legal), Sewa Bhawan (North Wing), Room No. 622, 6th Floor, R. K. Puram, New Delhi-110066 by post or through e-mail ([celegal-cea@gov.in](mailto:celegal-cea@gov.in)) latest by 14.02.2022.

**Members may note.**

## PART C: ITEMS FOR UPDATE

### ITEM NO. C.1: ER Grid performance during December 2021

The average and maximum consumption of Eastern Region and Max/Min Demand (MW), Energy Export for the month December-2021 were as follows:

| Average Consumption (MU) | Maximum Consumption (MU)/ Date | Maximum Demand (MW) Date/Time         | Minimum Demand (MW) Date/Time            | Schedule Export (MU) | Actual Export (MU) |
|--------------------------|--------------------------------|---------------------------------------|--|----------------------|--------------------|
| 380.9                    | 408<br>24-12-2021              | 20603 MW,<br>23-12-2021<br>18:52 Hrs. | 11949 MW,<br>29-12-2021 at<br>03:49 Hrs. | 5052                 | 4978               |

**ERLDC may Highlight the Performance of Eastern Regional Grid.**

### ITEM NO. C.2: Review of implementation of PSDF approved projects of ER.

In 10<sup>th</sup> NPC meeting held on 09.04.2021, RPCs were advised take up the matter for improvement of the fund disbursement and expeditious implementation of the sanctioned projects under PSDF.

In view of the above, status review of the projects being executed under PSDF funding in Eastern Region would be carried out on regular basis for expediting the projects. All the constituents are requested to furnish/update the status of their respective project in every month.

Concerned utilities may update the present status of the project as given in the **Annexure-C.2**.

**Members may update.**

### ITEM NO. C.3: Status of implementation of AGC as a pilot project in States.

In 42<sup>nd</sup> TCC, DVC intimated that AGC shall be implemented in unit 7 and 8 of Mejia as per the given schedule by 31st July 2020.

WBPDCCL informed that they have already collected offer from Siemens for implementation of

AGC and they are awaiting the concurrence from SLDC.

SLDC, WB informed that they are not in a position to implement AGC unless a clear direction is given by WBERC. Further, implementation of intra state DSM is a prerequisite for implementation of AGC in the states.

It was decided to request CERC to include this as an issue in the agenda for discussion in the meeting of Forum of Regulators.

OCC advised SLDC Odisha and OPGC to interact with Barh NTPC & ERLDC to get the technical specifications & the procedure for implementation of AGC.

In the 183<sup>rd</sup> OCC meeting, OPGC representative informed that work order has been issued to M/s Siemens for implementation of AGC. The work would be carried out during the unit shutdown which is scheduled from 18.10.2021.

| State  | Station/Unit    | Deliberation in 184 <sup>th</sup> OCC Meeting  |
|--------|-----------------|--|
| DVC    | Mejia unit#7 &8 | DVC representative informed that NIT is to be floated.   |
| Odisha | Unit#3 of OPGC  | OPGC vide email dated 25 <sup>th</sup> Oct'21 informed that some additional data is needed from SLDC Odisha and after getting the same AGC would be implemented. |

In the 185<sup>th</sup> OCC meeting, DVC representative informed that the NIT for implementation of AGC will be floated by 9<sup>th</sup> December 2021.

OPGC representative was not present during the discussion.

In the 186<sup>th</sup> OCC meeting, DVC representative informed that the NIT would be floated by 31<sup>st</sup> December 2021.

**Members may update.**

**ITEM NO. C.4: Primary Frequency Response Testing of ISGS Generating Units**

In the 180<sup>th</sup> OCC meeting, ERLDC representative informed that as per communication received from GMR and JITPL PFR testing has been scheduled by Siemens in August'21.

MPL representative submitted that they would carry out the PFR testing in the month of July'21.

In the 181<sup>st</sup> OCC meeting, ERLDC representative informed that PFR testing of MPL got postponed due to some technical issue. He further informed that PFR testing is going on in APNRL and that of NPGC and BRBCL is scheduled in the last week of July'21 and 1<sup>st</sup> week of August'21 respectively.

In the 182<sup>nd</sup> OCC meeting, ERLDC representative submitted that During July – August 2021, PFR testing has been conducted at the following generating units:

1. Adhunik TPS Unit 1 & 2
2. BRBCL TPS Unit 2 & 3
3. Nabinagar STPS Unit 1
4. Kahalgaon STPS Unit 1

In the 183<sup>rd</sup> OCC meeting, ERLDC representative updated that PFR testing for Unit# 1 & 2 of GMR had been completed.

The updated status is enclosed at **Annexure-C4**.

In the 185<sup>th</sup> OCC meeting, ERLDC representative informed that PFR testing of Dikchu is being carried out.

The Committee advised all the members to provide the updated status of PFR testing, if any, to the ERPC and ERLDC.

**Members may update.**

**ITEM NO. C.5: Testing of Primary Frequency Response of State Generating units by third party agency.**

In the 171<sup>st</sup> OCC Meeting, OCC advised all the SLDC's to prepare the action plan for their state generators and submit the details to ERPC and ERLDC at the earliest.

DVC vide-mail dated 6<sup>th</sup> Oct 2020 informed that the Primary Frequency Response Testing may be carried out for the following generating units:

| Sl. No. | Name of the Units  | Capacity (MW)             |
|---------|--------------------|---------------------------|
| 1       | BTPS-A             | 500                       |
| 2       | CTPS Unit #7&8     | 2X250                     |
| 3       | DSTPS Unit#1&2     | 2X500                     |
| 4       | KTPS Unit # 1&2    | 2X500                     |
| 5       | MTPS Unit # 3 to 8 | 2 X 210 +2 X 250 + 2X 500 |
| 6       | RTPS Unit # 1 & 2  | 2 X 600                   |

In the 182<sup>nd</sup> OCC meeting, WBPDC representative submitted that they had taken the budgetary offer form Siemens and Solvina and the same is in process for administrative approval. PO would be issued to the selected party after getting the necessary approval.

Jharkhand representative submitted that no update has been obtained from Tenughat in this regard.

DVC representative submitted that the Indent for this work had been placed in April'21 and they are in the process for floating the NIT.OHPC representative submitted that the order would be

issued to M/s Solvina by 1<sup>st</sup> week of September'2021.

In the 183<sup>rd</sup> OCC meeting, OHPC representative submitted that work order has been placed on M/s Solvina and they are planning to conduct the test in the month of Nov'21 for unit#5 of Rengali& Unit #4 of Indravati HEP.

TVNL representative submitted that due to coal shortage issue, the PFR testing of Unit #1 could not be planned. The same would be taken up once the coal supply gets improved.

WBPDC representative submitted that they are yet to receive the administrative approval. The work order would be placed after getting the approval.

In the 184<sup>th</sup> OCC meeting, OHPC representative submitted that the order has been placed to M/s Solvina on 3rd Sept'21 and the testing of unit#5 of Rengali & Unit #4 of Indravati HEP are scheduled to be conducted in the month of Nov'21.

TVNL representative was not available in the meeting.

WBPDCL representative submitted that the tender has been floated and the bid opening is scheduled in the 1st week of Nov'21. He further informed that the order would be placed by 3<sup>rd</sup> week of November'21.

In the 185<sup>th</sup> OCC meeting, OHPC representative informed that testing of Primary Frequency Response of all the units of Rengali and Indravati will be done by the end of December 2021.

WBPDCL representative informed that they will place the order in the month of December 2021.

In the 186<sup>th</sup> OCC Meeting, OHPC representative informed that the testing of Primary Frequency Response of all the units of Rengali and Indravati would be done by the 2<sup>nd</sup> week of January 2022.

DVC representative informed that the bid opening had been done on 22<sup>nd</sup> December 2021.

**Members may update.**

**ITEM NO. C.6: PSS tuning of Generators in Eastern Region.**

The PSS tuning activity is mandatory in line with IEGC and CEA regulations. The Procedure of PSS tuning for helping utilities in getting this activity carried out has been approved in 171<sup>st</sup> OCC Meeting and shared with all concerned utilities.

CESC representative submitted that PSS tuning for Budge Budge unit#1 & 2 was done on 16<sup>th</sup>& 17<sup>th</sup> Aug'21 respectively.

ERLDC representative informed that PSS tuning for Mejia unit#4, Mangdechhu unit#3 & 4, DPL unit#7 and Kahalgaon unit#2 was done satisfactorily. However, PSS tuning for APNRL was not successful.

DGPC Bhutan representative submitted that for Chuka, Tala and Mangdechhu they had shared their report to ERPC.

In the 183<sup>rd</sup> OCC meeting, DVC representative informed that for PSS tuning for Unit#1 of Koderma TPS was carried out on 07/09/2021.

OCC advised DVC to submit the test report to ERLDC/ERPC.

In the 184<sup>th</sup> OCC meeting, ERLDC representative submitted that PSS tuning for Teesta-III is scheduled on 17th Nov'21. However, update from Bhutan is still pending.

OHPC representative mentioned that PSS tuning for all the units of Rengali was carried out from 10<sup>th</sup> to 13th Oct'21 and was tuned properly. He further added that the report would be shared to ERPC and ERLDC.

The updated schedule for PSS tuning of the units is attached at **Annexure-C6**.

In the 185<sup>th</sup> OCC meeting, ERLDC informed the forum that PSS Tuning of Teesta-V was



conducted but was not successful. Further, it was also informed that Rongnichu and Chuzachen are also going to carry out the PSS Tuning.

In the 186<sup>th</sup> OCC Meeting, Teesta –V representative informed that the PSS tuning would be conducted in the last week of January 2022.

It was informed in the OCC that PSS tuning of Rongnichu and Chuzachen had been completed.

DVC representative informed that PSS tuning of RTPS unit-1 & 2 would be done in the month of March 2022.

BRBCL representative informed that PSS tuning of BRBCL unit-1 has also been completed.

**Members may update.**

**ITEM NO. C.7: Status of UFRs healthiness installed in Eastern Region.**

**Members may update** the status of UFR healthiness installed in Eastern Region.

**ITEM NO. C.8: Status of Islanding Schemes healthiness installed in Eastern Region.**

As per the decision taken in the meeting held on 8<sup>th</sup> July 2021 and chaired by member (GO&D), CEA, data in prescribed formats may be submitted by concerned utilities to RPCs on monthly basis to certify the healthiness of the Islanding Schemes.

**a. Format - I for RLDC/SLDCs**

| S.NO | Name of Islanding Scheme | Healthiness of Communication channel |
|------|--------------------------|--------------------------------------|
|      |                          |                                      |

**b. Format - II for Generating Station**

| S.NO | Name of Islanding Scheme | Healthiness of Islanding Relay | Healthiness of Communication channel |
|------|--------------------------|--------------------------------|--------------------------------------|
|      |                          |                                |                                      |

**c. Format - III for Transmission Utility/DISCOMs**

| S.NO | Name of Islanding Scheme | Elements considered for tripping to from Island | For communication-based tripping logic Of feeders | For UFR based tripping logic of feeders |
|------|--------------------------|---|---|---|
|      |                          |   |   |   |

|  |  |  |   |   |                              |
|--|--|--|---|---|------------------------------|
|  |  |  | <b>Healthiness of Communication channel</b> | <b>Healthiness of PT Fuse and status of DC supply to UFR relay*</b> | <b>Healthiness of Relay#</b> |
|  |  |  |   |   |                              |

\* Where dedicated UFR relay have been installed for tripping of the feeders under Islanding scheme

# Where UFR functions have been enabled within backup protection relay of the line.

**d. Format - IV for collecting Relay details of the Islanding scheme.**

The following format may be used to get Relay details of the Islanding scheme:

| <b>S.NO</b> | <b>Description</b>   | <b>UFRs-for load relief (A)</b> | <b>df/dt -for load relief (B)</b> | <b>Relay for Island creation(C)</b> |
|-------------|--|---------------------------------|-----------------------------------|-------------------------------------|
| 1           | Relay location (S/s name)  |                                 |                                   |                                     |
| 2           | Relay make & model   |                                 |                                   |                                     |
| 3           | Frequency setting of the relay (at which load shedding is envisaged)   |                                 |                                   |                                     |
| 4           | Feeder name (voltage level and source-destination name) signaled by the Islanding Relay for separation /load shedding/separation from outside grid |                                 |                                   |                                     |
| 5           | Quantum of load relief due to tripping of feeder (as per state's peak of previous year)  |                                 |                                   |                                     |
| 6           | Quantum of load (Min, Avg, Max in MW) on the feeder (as per state's peak of previous year)   |                                 |                                   |                                     |

**e. Format - V for Contact details of all Nodal Officer**

| <b>Utility Name &amp; Location</b> | <b>Name</b> | <b>Designation</b> | <b>Organization</b> | <b>Email ID</b> | <b>Mobile No.</b> |
|------------------------------------|-------------|--------------------|---------------------|-----------------|-------------------|
|                                    |             |                    |                     |                 |                   |

It was deliberated in the 186<sup>th</sup> OCC meeting that except West Bengal all the entities are sending the report as per the new format.

**Members may update.**

**ITEM NO. C.9: Transfer capability determination by the states.**

**Latest status of State ATC/TTC declared by states during the month of February-2022**

To harmonise the ATC/TTC calculation methodology and timeline One to one meeting and hands on training with each SLDC was conducted in the month of Sep-21 and Oct-21. As per the common agreed procedure and timeline ATC/TTC calculation in three months advance and reconciliation of the TTC/ATC figure for the upcoming month between RLDC and SLDC has started from month Dec-21. Reconciled ATC/TTC figure are as follows:

| SI No | State/Utility | TTC (MW) |        | RM(MW) |        | ATC Import (MW) |        | Remark |
|-------|---------------|----------|--------|--------|--------|-----------------|--------|--------|
|       |               | Import   | Export | Import | Export | Import          | Export |        |
| 1     | BSPTCL        | 5150     | --     | 103    | --     | 5047            | --     | Feb-22 |
| 2     | JUSNL         | 1702     | --     | 49     | --     | 1653            | --     | Feb-22 |
| 3     | DVC           | 1577     | 2878   | 63     | 50     | 1514            | 2828   | Feb-22 |
| 4     | OPTCL         | 2770     | 1154   | 104    | 59     | 2666            | 1095   | Feb-22 |
| 5     | WBSETCL       | 5488     | --     | 450    | --     | 5031            | --     | Feb-22 |
| 6     | Sikkim        | 148      | --     | 2.48   | --     | 145.52          | --     | Feb-22 |

As per the agreed philosophy the status of month wise ATC/TTC submission is as follows:

| State         | Bihar     | Jharkhand | DVC       | Odisha    | West Bengal | Sikkim    |
|---------------|-----------|-----------|-----------|-----------|-------------|-----------|
| <b>Month</b>  |           |           |           |           |             |           |
| <b>Jan-22</b> | Submitted | Submitted | Submitted | Submitted | Submitted   | Submitted |
| <b>Feb-22</b> | Submitted | Submitted | Submitted | Submitted | Submitted   | Submitted |
| <b>Mar-22</b> | Submitted | Submitted | Submitted | Submitted | Submitted   | Pending   |
| <b>Apr-22</b> | Pending   | Pending   | Pending   | Submitted | Pending     | Pending   |
| <b>May-22</b> | Pending   | Pending   | Pending   | Pending   | Pending     | Pending   |

**Declaration of TTC/ATC on SLDC Website:**

| SI. No | SLDC   | Declared on Website | Website Link  | Constraint Available on Website | Type of Website Link  |
|--------|--------|---------------------|---|---------------------------------|-----------------------|
| 1      | BSPTCL | Yes                 | <a href="http://www.bsptcl.in/ViewATCTTCWeb.aspx?GL=12&amp;PL=10">http://www.bsptcl.in/ViewATCTTCWeb.aspx?GL=12&amp;PL=10</a> | Yes                             | Static Link-Table     |
| 2      | JUSNL  | Yes                 | <a href="http://www.jusnl.in/pdf/download/ttc_atc_nov_2020.pdf">http://www.jusnl.in/pdf/download/ttc_atc_nov_2020.pdf</a>     | Yes                             | Static link –pdf file |
| 3      | DVC    | Yes                 | <a href="https://application.dvc.gov.in/CLD/atctcmenu.jsp#">https://application.dvc.gov.in/CLD/atctcmenu.jsp#</a>             | Yes                             | Static Link-Word file |

|   |         |     |   |                   |                        |
|---|---------|-----|---|-------------------|------------------------|
| 4 | OPTCL   | Yes | <a href="https://www.sldcorissa.org.in/TTC_ATC.aspx">https://www.sldcorissa.org.in/TTC_ATC.aspx</a> | Yes               | Static Link-pdf file   |
| 5 | WBSETCL | Yes | <a href="http://www.wbsldc.in/atc-ffc">http://www.wbsldc.in/atc-ffc</a>                             | No (Not updating) | Static Link-Table      |
| 6 | Sikkim  | No  | <a href="https://power.sikkim.gov.in/atc-and-ffc">https://power.sikkim.gov.in/atc-and-ffc</a>       | No (Not updating) | Static Link-Excel file |

It is necessary to highlight that the ATC/TTC declaration on website need to be updated in timely manner. It is suggested that along with PDF copies, a tabular format may also kindly be provided so that it can be utilized for preparing ERLDC portal on State ATC/TTC. In addition, ATC/TTC may be declared three months in advance and periodically reviewed based on any shutdown causing leading to any constraint.

**Members may update.**

**ITEM NO. C.10: Mock Black start exercises in Eastern Region**

Mock black start date for financial year 2021-22 is as follows:

| Sl. No | Name of Hydro Station | Schedule                         | Tentative Date | Schedule                  | Tentative Date |
|--------|-----------------------|----------------------------------|----------------|---------------------------|----------------|
|        |                       | Test-I                           |                | Test-II                   |                |
| 1      | U. Kolab              | Last week of Oct 2021            |                | Second Week of Feb 2022   |                |
| 2      | Balimela              | Second week of Nov 2021          |                | First Week of March 2022  |                |
| 3      | Rengali               | Second week of Nov 2021          |                | First 2week of March 2022 |                |
| 4      | Burla                 | Second week of Nov 2021          |                | First Week of March 2022  |                |
| 5      | U. Indravati          | Last week of Oct 2021            |                | Second Week of Feb 2022   |                |
| 6      | Maithon               | Third Week of Nov 2021           |                | First Week of March 2022  |                |
| 7      | TLDP-III              | Second week of Nov 2021          |                | Second Week of Feb 2022   |                |
| 8      | TLDP-IV               | Third Week of Nov 2021           |                | First Week of March 2022  |                |
| 9      | Subarnarekha          | Second week of Nov 2021          |                | Second Week of Feb 2022   |                |
| 10     | Teesta-V              | Third Week of Nov 2020           |                | Third Week of March 2022  |                |
| 11     | Chuzachen             | Done on 9 <sup>th</sup> April'21 |                | First Week of March 2022  |                |
| 12     | Teesta-III            | Third Week of Nov 2021           |                | First Week of March 2022  |                |
| 13     | Jorethang             | Third Week of                    |                | First Week of March       |                |

|    |           |                         |  |                          |  |
|----|-----------|-------------------------|--|--------------------------|--|
|    |           | Nov 2021                |  | 2022                     |  |
| 14 | Tasheding | Second week of Nov 2021 |  | First Week of March 2022 |  |
| 15 | Dikchu    | Second week of Nov 2021 |  | Second Week of Feb 2022  |  |

SLDC, Odisha representative informed that they would go for Mock Black Start of Balimela in the 2<sup>nd</sup> week of August '21.

In the 182<sup>nd</sup> OCC meeting, OHPC representative submitted that Mock Black Start had been done for Rengali on 18<sup>th</sup> August'21 and they would go for Mock Black Start of Balimela in Sept'21.

OCC advised the concerned utilities to give prior intimation to ERLDC and ERPC regarding Mock Black Start.

In the 183<sup>rd</sup> OCC meeting, SLDC Odisha representative informed that mock black start for Balimela has been scheduled in Nov-21.

Teesta III HEP representative submitted that mock black would be carried out for their plant in Nov'21 as per the schedule.

In the 185<sup>th</sup> OCC meeting, SLDC Odisha representative was not present in the discussion.

JUSNL vide letter dated 25.11.2021 informed that the Mock Black Start exercise at Subarnarekha Hydel Power, Sikidiri is scheduled on 03.12.2021 (Friday) from 11:00 hrs. to 13:00 hrs.

In the 186<sup>th</sup> OCC meeting, ERLDC representative informed that Mock Black Start of unit-7 of Burla and TLDP unit-4 were successfully completed on 15<sup>th</sup> & 16<sup>th</sup> December 2021 respectively.

Teesta-III representative informed that Mock Black Start would be done after completion of LILO work of Teesta-III Kishanganj.

Jharkhand representative informed that Mock Black Start at Subarnarekha was completed on 3<sup>rd</sup> December 2021.

Odisha representative informed that the Mock Black Start of Balimela is planned in the 2<sup>nd</sup> week of January 2022.

**Members may update.**

**ITEM NO. C.11: Updation of Black Start and Restoration procedure of Eastern Region**

As per clause IEGC 5.8(a)

“Detailed plans and procedures for restoration of the regional grid under partial/total blackout shall be developed by RLDC in consultation with NLDC, all Users, STU, SLDC, CTU and RPC Secretariat and shall be reviewed / updated annually.”

The restoration procedure of Eastern Region was last updated in the month of Jan-2021 and

same can be accessed through following link

[https://app.erldc.in/Content/Upload/System%20Study/System\\_Reliability%20report/ER%20Restoration%20procedure%20Jan%202021.pdf](https://app.erldc.in/Content/Upload/System%20Study/System_Reliability%20report/ER%20Restoration%20procedure%20Jan%202021.pdf)

ERLDC is in the process of updating Black Start and Restoration Procedure for Year 2022. All utilities are requested to go through the last updated restoration procedure and provide the input for changes if any. Further all the SLDCs are requested to share updated restoration procedure of their respective state so that information from same can be appropriately included in Eastern Regional Restoration Procedure.

**Till date comments/information received from Bihar, Jharkhand, DVC, Railways, BRBCL, Odisha and Jorethang. Others are requested to give the information at the earliest. Based on the comment received the Black Start and Restoration procedure of Eastern Region will be finalized by 31<sup>st</sup> Jan 2022.**

**ITEM NO. C.12: Status update on transmission constraint from the respective state.**

In the meeting Chaired by Joint Secretary (OM & RR) dated 12.01.2022, transmission constraints for drawl of power by states were discussed.

In line with same it is required to update on approved plan, prospective schedule of the project completion and reasons for delay in commissioning if any. List of the lines is given in **Annexure-C.12**.

**Members may update.**

## PART D: OPERATIONAL PLANNING

### **ITEM NO. D.1: Anticipated power supply position during February 2022**

The abstract of peak demand (MW) vis-à-vis availability and energy requirement vis-à-vis availability (MU) for the month of February 2022 were prepared by ERPC Secretariat on the basis of LGBR for 2021-22 and feedback of constituents, keeping in view that the units are available for generation and expected load growth etc. is enclosed at **Annexure D1**.

**Members may update.**

### **ITEM NO. D.2: Shutdown proposal of generating units for the month of February 2022**

Generator unit shutdown schedule for February' 2022 is given in the table:

| <b>Proposed Maintenance Schedule of Thermal Generating Units of ER during 2021-22 in the month of February' 2022</b> |                 |          |               |                              |            |             |                    |         |
|--|-----------------|----------|---------------|------------------------------|------------|-------------|--------------------|---------|
| System   | Station         | Unit No. | Capacity (MW) | Period (As per LGBR 2021-22) |            | No. of Days | Reason             | Remarks |
|  |                 |          |               | From                         | To         |             |                    |         |
| WBPDC  | Kolaghat TPS    | 5        | 210           | 01.02.2022                   | 09.02.2022 | 9           | PG Test            |         |
|  | Bakareshwar TPS | 2        | 210           | 10.02.2022                   | 19.02.2022 | 10          | PG Test            |         |
| CESC/HEL   | HEL             | 2        | 300           | 21.02.2022                   | 25.02.2022 | 5           | Short Maintenance  |         |
| NTPC   | Farakka STPS    | 5        | 500           | 01.02.2022                   | 17.03.2022 | 45          | Boiler+FGD+Turbine |         |
|  | Barh STPS       | 4        | 660           | 14.02.2022                   | 30.03.2022 | 45          | Boiler+LPT+IPT+HPT |         |
| DVC  | Mejia TPS       | 1        | 210           | 15.02.2022                   | 22.03.2022 | 36          | COH                |         |

**Members may update.**

### **ITEM NO. D.3: Shutdown of 400KV Nabinagar (NPGCL)-Patna D/C line.**

The following shutdown schedule was proposed by BSPTCL/BGCL for tower erection & stringing work associated with LILO of 400 kV NPGC-Patna D/c line at 400 kV Jakkampur (new) S/s.

In 187<sup>th</sup> OCC Outage Coordination meeting, BGCL was advised to explore the possibility of keeping one circuit in service using the ERS during the proposed shutdown. Further NPGC representative was not available in the meeting.

It was decided to discuss the proposed shutdown in the forthcoming OCC meeting.

| Element | Type | D/C | Reason                     | From Date | From Time | To Date | To Time |
|---------|------|-----|----------------------------|-----------|-----------|---------|---------|
| 400KV-  | LINE | C   | De-stringing/stringing and | 22-Feb-   | 08:00     | 07-Mar- | 18:00   |



|   |      |   |   |                 |       |                 |       |
|---|------|---|---|-----------------|-------|-----------------|-------|
| PATNA<br>-<br>NABIN<br>AGAR(<br>NPGC)-<br>1           |      |   | tower dismantling /erection<br>work LILO of 400 KV<br>D/C(Quad), Nabinagar II-<br>Patna (PG) transmission<br>line at Jakkanpur (New).                               | 2022            |       | 2022            |       |
| 400KV-<br>PATNA<br>-<br>NABIN<br>AGAR(<br>NPGC)-<br>2 | LINE | C | De-stringing/stringing and<br>tower dismantling /erection<br>work LILO of 400 KV<br>D/C(Quad), Nabinagar II-<br>Patna (PG) transmission<br>line at Jakkanpur (New). | 22-Feb-<br>2022 | 08:00 | 07-Mar-<br>2022 | 18:00 |

BSPTCL/BGCL may explain. NPGCL may respond.

**ITEM NO. D.4: Major Generating Units/Transmission Element outages/shutdown in ER Grid (as on 11.01.2022)**

**a) Thermal Generating Stations outage report:**

| SL No | STATION           | STATE       | AGENCY    | UNIT NO | CAPACITY (MW) | REASON(S)   | OUTAGE DATE |
|-------|-------------------|-------------|-----------|---------|---------------|---|-------------|
| 1     | KOLAGHAT          | WEST BENGAL | WBPD CL   | 1       | 210           | Initially taken under ESP R & M. Presently Under consideration for De-commissioning.                | 07-Jun-2018 |
| 2     | BARAUNI TPS       | BIHAR       | BSPHCL    | 6       | 110           | Abnormal TSI parameter  | 17-Mar-2021 |
| 3     | KOLAGHAT          | WEST BENGAL | WBPD CL   | 2       | 210           | Initially taken under ESP & Ash Handling R & M. Presently Under consideration for De-commissioning. | 26-Jun-2021 |
| 4     | MUZAFFARPUR TPS   | BIHAR       | BSPHCL    | 1       | 110           | Completion of tenure of PPA   | 08-Sep-2021 |
| 5     | MUZAFFARPUR TPS   | BIHAR       | BSPHCL    | 2       | 110           | Completion of tenure of PPA   | 08-Sep-2021 |
| 6     | TSTPP             | ODISHA      | NTPC      | 1       | 500           | For Annual overhauling  | 04-Dec-2021 |
| 7     | Sterlite          | ODISHA      | SEL       | 3       | 600           | Ash handling problem  | 08-Dec-2021 |
| 8     | BANDEL TPS        | WEST BENGAL | WBPD CL   | 5       | 210           | Annual overhauling  | 24-Dec-2021 |
| 9     | HALDIA ENERGY LTD | WEST BENGAL | HEL, CESC | 1       | 300           | Annual overhauling  | 05-Jan-2022 |

|    |                |             |         |   |     |   |             |
|----|----------------|-------------|---------|---|-----|---|-------------|
| 10 | BOKARO-A'      | DVC         | DVC     | 1 | 500 | Ash pond evacuation problem                             | 05-Jan-2022 |
| 11 | HEL HIRANMAYEE | WEST BENGAL | WBPD CL | 2 | 150 | Tripped due to Turbine thrust bearing temperature high. | 05-Jan-2022 |
| 12 | SANTALDIH TPS  | WEST BENGAL | WBPD CL | 5 | 250 | Annual overhauling                                      | 07-Jan-2022 |
| 13 | DARLIPALI      | ODISHA      | NTPC    | 1 | 800 | Boiler Tube Leakage                                     | 09-Jan-2022 |
| 14 | WARIA TPS      | DVC         | DVC     | 4 | 210 | Due to suspected re-heater tube leakage.                | 09-Jan-2022 |
| 15 | BARH           | BIHAR       | NTPC    | 4 | 660 | Boiler Tube Leakage                                     | 11-Jan-2022 |
| 16 | OPGC           | ODISHA      | OPGC    | 4 | 660 | Boiler Tube Leakage                                     | 11-Jan-2022 |

All Generating stations are requested to update expected restoration time and reason outage to ERLDC/ERPC on weekly basis in case of any change at their end.

Generators/ constituents are requested to update the expected date of revival of the units.

b) Major Generating stations Out on Reserve Shutdown due to low system demand:

| S. NO | STATION     | STATE | AGENCY | UNIT NO | CAPACITY (MW) | REASON(S)   | OUTAGE DATE |
|-------|-------------|-------|--------|---------|---------------|---|-------------|
| 1     | BARAUNI TPS | BIHAR | BSPHCL | 7       | 110           | RSD/ LOW SYSTEM DEMAND  | 29-Oct-2021 |
| 2     | MEJIA TPS   | DVC   | DVC    | 1       | 210           | TRIPPED ON BTL. LATER THE UNIT IS DECLARED OUT ON LOW SYSTEM DEMAND | 14-Dec-2021 |

c) Hydro Unit Outage Report:

| S. NO | STATION             | STATE  | AGENCY | UNIT NO | CAPACITY (MW) | REASON(S)                               | OUTAGE DATE |
|-------|---------------------|--------|--------|---------|---------------|---|-------------|
| 1     | BALIMELA HPS        | ODISHA | OHPC   | 1       | 60            | R & M WORK                              | 05-Aug-2016 |
| 2     | BALIMELA HPS        | ODISHA | OHPC   | 2       | 60            | R & M WORK                              | 20-Nov-2017 |
| 3     | BURLA HPS/HIRAKUD I | ODISHA | OHPC   | 5       | 37.5          | R & M WORK                              | 25-Oct-2016 |
| 4     | RENGALI HPS         | ODISHA | OHPC   | 3       | 50            | DUE TO HEAVY OIL LEAKAGE FROM SUMP TANK | 19-Jul-2021 |

It is seen that about 207.5 MW hydro capacities in Odisha is under forced outage / planned outage and therefore not available for providing the much-needed peaking support during evening peak.

SLDC / OHPC may please indicate restoration plan of the units.

d) Long outage report of transmission lines:

| SL. NO | TRANSMISSION ELEMENT / ICT                | AGENCY       | OUTAGE DATE | REASONS FOR OUTAGE  |
|--------|---|--------------|-------------|---|
| 1      | 400 KV IBEUL JHARSUGUDA D/C               | IBEUL        | 29.04.2018  | TOWER COLLAPSE AT LOC 44,45   |
| 2      | 220/132 KV 100 MVA ICT II AT LALMATIA     | FSTPP/JU SNL | 22.01.2019  | FAILURE OF HV SIDE BREAKER  |
| 3      | 220 KV PANDIABILI - SAMANGARA D/C         | OPTCL        | 03.05.2019  | 49 NOS OF TOWER COLLAPSED.AS REPORTED BY SLDC OPTCL, TOTAL 60 NOS OF TOWER IN BETWEEN 220KV PANDIABILI – SAMANGARA LINE IN WHICH 48 NOS TOWERS FULLY DAMAGED AND 12 NOS TOWERS PARTIALLY DAMAGED. WORK UNDER PROGRESS. PRESENTLY CHARGED FROM PANDIABILLI END (LOC 156) TO LOC 58 |
| 4      | 220KV BARAUNI-HAJIPUR CKT-1               | BSPTCL       | 28.09.2019  | TOWER COLLAPSE AT LOCATION 38 & 39. CKT-2 IS ON ERS SINCE 13.01.2020.   |
| 5      | 220/132 KV 100 MVA ICT 3 AT CHANDIL       | JUSNL        | 30.04.2020  | ICT BURST AND DAMAGED AFTER FIRE REPORTED   |
| 6      | 220KV/132 KV 100 MVA ICT 4 AT RANGPO      | PGCIL        | 08.04.2021  | HAND TRIPPED AFTER TRIPPING OF ALL 400/220 ICTS AT RANGPO ON 08/04/21 AFTER DISTURBANCE AND THERAFTER DEVELOPED RELAY RESET PROBLEM, NOT COMMISSIONED.  |
| 7      | 400KV/220KV 315 MVA ICT 2 AT MEERAMUNDALI | OPTCL        | 21.02.2021  | FIRE HAZARD   |
| 8      | 400KV/220KV 315 MVA ICT 4 AT JEERAT       | WBSETCL      | 09.04.2021  | VERBALLY CONFIRMED BY WB THAT NEW TRANSFORMER PROCUREMENT UNDER PIPELINE AND SHALL BE REPLACED IN THE NEAR FUTURE.  |

|    |                        |               |            |   |
|----|------------------------|---------------|------------|---|
| 9  | 220KV-FSTPP-LALMATIA   | JUSNL         | 21.04.2021 | THREE TOWER COLLAPSED NEAR LALMATIA   |
| 10 | 220KV-CHUKHA-BIRPARA-2 | PGCIL/ Bhutan | 29.12.2021 | BENDING OF TOWER NO. CB113 REPORTED. LINE IS ANTITHEFT CHARGED FROM BIRPARA UPTO INDIA BORDER.                            |
| 11 | 400KV-BINAGURI-TALA-4  | PGCIL/ Bhutan | 31.12.2021 | S/D TAKEN BY BHUTAN AS TALA GENERATION IS GOING IN SHUTDOWN TILL END OF MARCH,2022 TO CARRY OUT RECTIFICATION WORK IN HRT |

Transmission licensees/ Utilities are requested to update expected restoration date & work progress regarding restoration regularly to ERLDC/ERPC on monthly basis by 5th of each month so that status of restoration can be reviewed in OCC. Utilities are also requested to update outage of any elements within their substation premises like isolator/breaker to ERLDC/ERPC regularly. (Reported as per Clause 5.2(e) of IEGC).

**Members may update.**

**ITEM NO. D.5: Commissioning of new units and transmission elements in Eastern Grid in the month of December-2021**

The details of new units/transmission elements commissioned in the month of December-2021 based on the inputs received from beneficiaries:

| NEW ELEMENTS COMMISSIONED IN DECEMBER-2021 |         |               |                                      |                    |                    |                |           |  |                              |
|--|---------|---------------|--------------------------------------|--------------------|--------------------|----------------|-----------|--|------------------------------|
| ICTs                                       |         |               |                                      |                    |                    |                |           |  |                              |
| REGION                                     | SL. NO. | Agency/ Owner | SUB-STATION                          | ICT NO             | Voltage Level (kV) | CAPACITY (MVA) | DATE      | TIME                                   | REMARKS                      |
| ER   | 1       | JUSNL/TVNL    | Tenughat                             | 1                  | 400                | 250            | 20-Dec-21 | 17:15                                  | ICT Charged from 220 kV Side |
|  | 2       | JUSNL         | Patratu                              | 2                  | 400                | 315            | 29-Dec-21 | 18:04                                  |                              |
| TRANSMISSION LINES                         |         |               |                                      |                    |                    |                |           |  |                              |
| REGION                                     | SL. NO. | Agency/ Owner | LINE NAME                            | Length (KM)        | Conductor Type     | DATE           | TIME      | REMARKS                                |                              |
| ER   | 1       | SLDC ODISHA   | 33KV-DARLIPALLI (NTPC)-DULANGA CMP-2 | 7.5(OH) + 0.8 XLPE | PANTHER            | 24-Dec-21      | 17:31     | OH, is Overhead plus 0.8 KM XLPE cable |                              |
|  | 2       | JUSNL         | 400KV-NEW RANCHI-PATRATU-1           | 48.986             | ACSR TWIN MOOSE    | 29-Dec-21      | 14:24     |  |                              |

|   | 3       | JUSNL         | 400KV-NEW RANCHI-PATRATU-2                              | 48.986      | ACSR TWIN MOOSE    | 29-Dec-21 | 16:06 |   |
|---|---------|---------------|---|-------------|--------------------|-----------|-------|---|
| <b>LILO/Re-Arrangement OF TRANSMISSION LINES</b>  |         |               |   |             |                    |           |       |   |
| REGION  | SL. NO. | Agency/ Owner | LINE NAME/LILO at                                       | Length (KM) | Conductor Type     | DATE      | TIME  | REMARKS   |
| ER  | 1       | PGCIL ER-II   | 400KV-DURGAPUR-KAHALGAON-2                              | 242.941     | ACSR TWIN MOOSE    | 18-Dec-21 | 18:09 | It is reconfiguration of 400 kV Kahalgaon-Farakka III & IV and 400 kV Farakka-Durgapur I & II bypassing Farakka and it will ultimately form 400 kV Durgapur-Kahalgaon-I & II. |
|   | 2       | PGCIL ER-II   | 400KV-DURGAPUR-KAHALGAON-1                              | 242.941     | ACSR TWIN MOOSE    | 29-Dec-21 | 15:10 |   |
| <b>Bays of Line/ICT/Reactor associated System</b> |         |               |   |             |                    |           |       |   |
| REGION  | SL. NO. | Agency/ Owner | Element Name  | SUB-STATION | Voltage Level (kV) | DATE      | TIME  | REMARKS   |
| ER  | 1       | PMTL          | 400KV MAIN BAY OF PATNA -1 AT SAHARSA                   | SAHARSA     | 400                | 8-Dec-21  | 17:39 | Charged through only Tie Bay 409 on 02 October. FTC of Main Bay is done only.   |
|   | 2       | JUSNL/TVNL    | 400KV MAIN BAY OF 400KV/220KV 250 MVA ICT 1 AT TENUGHAT | TENUGHAT    | 400                | 20-Dec-21 | 17:36 |   |
|   | 3       | JUSNL/TVNL    | 220KV MAIN BAY OF 400KV/220KV 250 MVA ICT               | TENUGHAT    | 220                | 20-Dec-21 | 17:15 |   |

|            |            |                  | 1 AT<br>TENUGHAT   |                     |                          |               |       |             |
|------------|------------|------------------|--|---------------------|--------------------------|---------------|-------|-------------|
|            | 4          | JUSNL            | 400KV MAIN<br>BAY OF NEW<br>RANCHI -2 AT<br>PATRATU              | PATRA<br>TU         | 400                      | 29-<br>Dec-21 | 16:06 |             |
|            | 5          | JUSNL            | 400KV TIE<br>BAY OF NEW<br>RANCHI -2<br>AND FUTURE<br>AT PATRATU | PATRA<br>TU         | 400                      | 29-<br>Dec-21 | 16:09 |             |
| <b>BUS</b> |            |                  |  |                     |                          |               |       |             |
| REGI<br>ON | SL.<br>NO. | Agency/<br>Owner | Element Name   | SUB-<br>STATI<br>ON | Voltage<br>Level<br>(kV) | DATE          | TIME  | REMAR<br>KS |
| ER         | 1          | JUSNL            | 400KV MAIN<br>BUS - 1 AT<br>PATRATU                              | PATRA<br>TU         | 400                      | 29-<br>Dec-21 | 14:24 |             |
|            | 2          | JUSNL            | 400KV MAIN<br>BUS - 2 AT<br>PATRATU                              | PATRA<br>TU         | 400                      | 29-<br>Dec-21 | 16:09 |             |

Members may update.

**ITEM NO. D.6: UFR operation during the month of December 2021**

Frequency profile for the month as follows:

| Month                | Max  | Min  | Less IEGC<br>Band (%) | Within IEGC<br>Band (%) | More IEGC<br>Band (%) |
|----------------------|--|--|-----------------------|-------------------------|-----------------------|
|                      | (Date/Time)                                | (Date/Time)                                |                       |                         |                       |
| <b>Dec,<br/>2021</b> | 50.34 Hz on<br>20.12.2021 at<br>02:03 Hrs. | 49.62 Hz on<br>31.12.2021 at<br>11:54 Hrs. | 06.92                 | 73.14                   | 19.95                 |

Hence, no report of operation of UFR has been received from any of the constituents.

Members may note.

## Exercise in regard to forecast of all India energy requirement and peak demand from Jan-22 to Dec-22

Date: 23/12/21

### Section-I:

#### **Introduction:**

All India energy consumption for last five years i.e. from January 2019 to 19<sup>th</sup> December 2021 is given in figure-1.

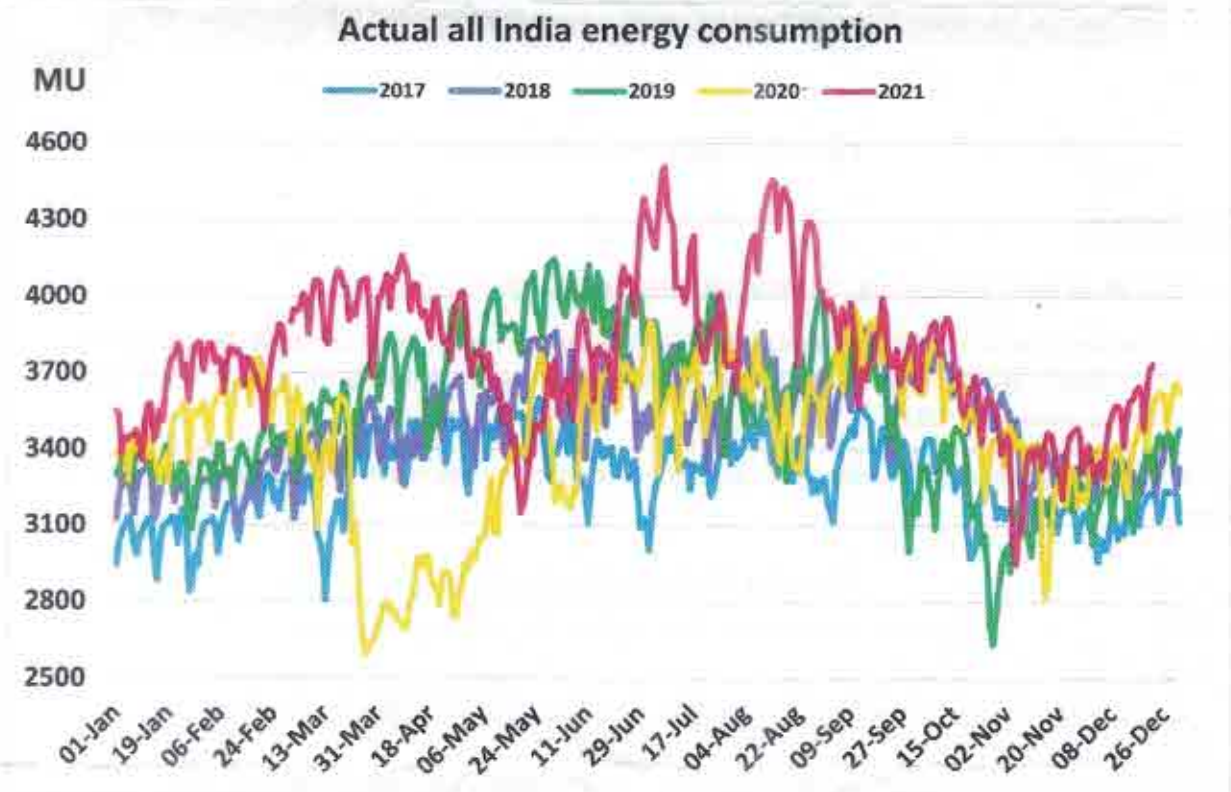

**Figure 1: All India energy consumption**

Last 5 years data has been examined to understand the all India energy consumption pattern. Generally, it is observed that energy consumption starts increasing from last week of December and continue till June and afterwards it starts to decline with the onset of monsoon rains. All India energy consumption pattern of year 2020 & 2021 were inconsistent, as lockdown was imposed during March-2020 to June-20 and April-21 to May-21 to contain COVID-19 pandemic.

Further, it is to mention that in the recent past, it has been seen that coal stocks at the power plants get depleted drastically from June onwards resulted in less availability of thermal based generation across the country. A plot of plant level all India coal stocks (TT) and number of days of coal stock is given in figure2.



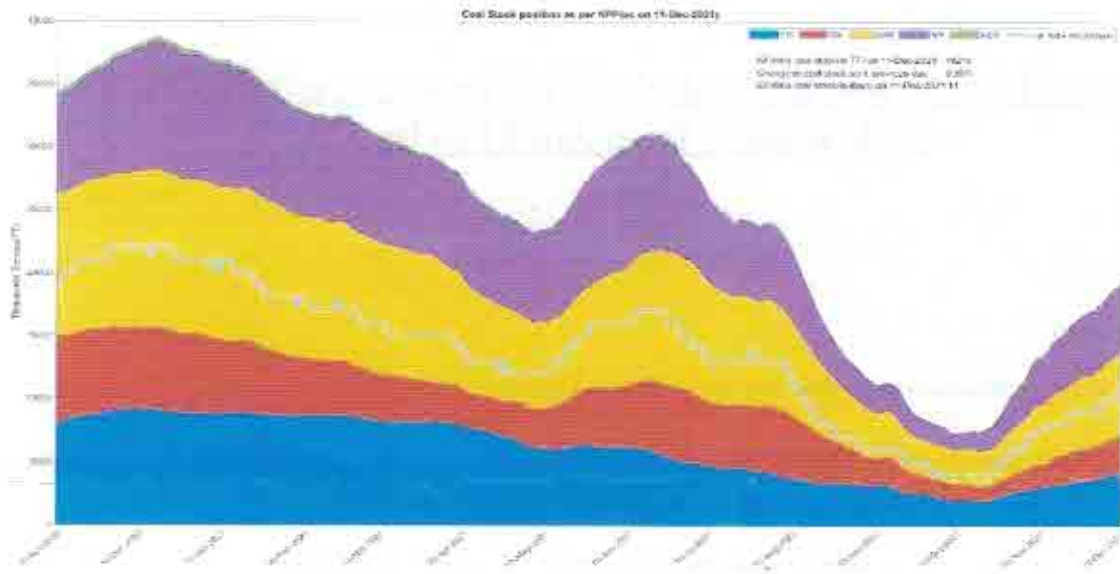

Figure 2:All India coal stock position

## Section-II:

### Forecast of all India energy requirement and peak demand:

An exercise has been carried out to forecast the all India energy requirement and peak demand for the 2022. Accordingly, requirement of coal-based generation has been computed to meet the estimated demand/consumption in 2022.

The actual energy consumption from 2019-2021 and forecasted energy requirement for 2022 is given in figure 3.

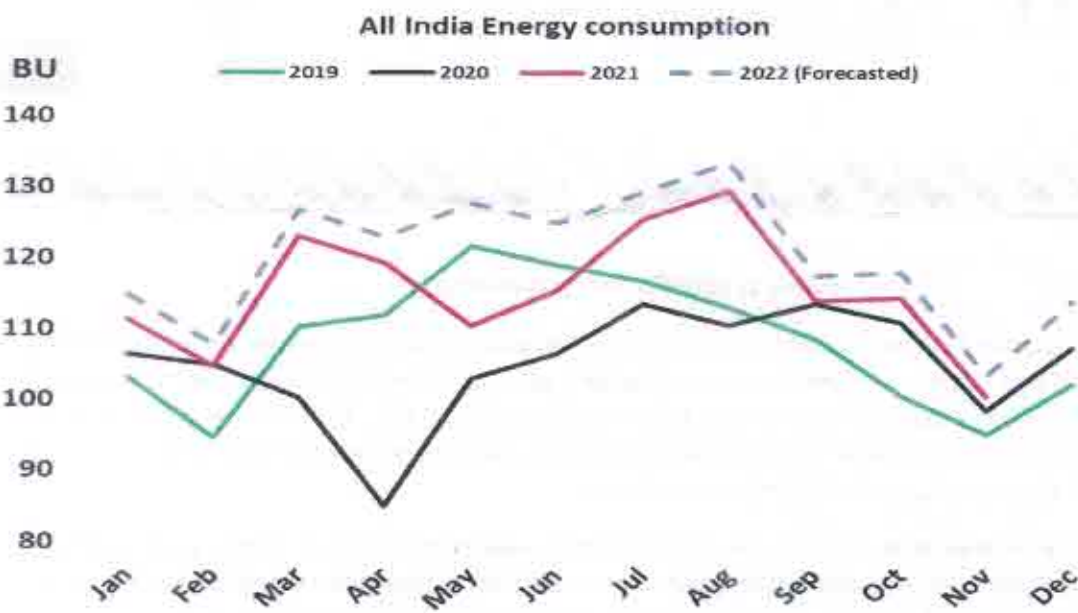

Figure 3:All India energy consumption

Forecasted all India energy requirement from Jan-22 to Dec-22 and required coal-based generation to meet the forecasted demand/energy consumption is given in Table-1.

**Table 1:Forecasted monthly thermal generation and domestic coal requirement (MT/month)**

| <b>Forecasted monthly thermal generation and domestic coal requirement (MT/month)</b> |   |  |  |   |  |  |
|---|---|--|--|---|--|--|
| <b>Month/Year</b>   | <b>Total All India energy requirement including Tr. Losses (MU)</b> | <b>Estimated Gross Thermal ( MU) (a)</b> | <b>Estimated lignite-based generation (MU) (b)</b> | <b>Estimated Imported coal-based generation ( MU) (c)</b> | <b>Energy to be met from domestic coal generation (MU) (d)=a-b-c</b> | <b>Estimated domestic coal requirement (MT/month) (e)= d*0.68/1000</b> |
| Jan-22  | 114773  | 94468                                    | 2170   | 3968  | 88330  | 60.1   |
| Feb-22  | 107885  | 87597                                    | 1960   | 3584  | 82053  | 55.8   |
| Mar-22  | 126737  | 104554                                   | 2170   | 3968  | 98416  | 66.9   |
| Apr-22  | 122854  | 100653                                   | 2100   | 3840  | 94713  | 64.4   |
| May-22  | 127634  | 98348                                    | 2170   | 3968  | 92210  | 62.7   |
| Jun-22  | 124880  | 91737                                    | 2100   | 3840  | 85797  | 58.3   |
| Jul-22  | 129270  | 92983                                    | 2170   | 3968  | 86845  | 59.1   |
| Aug-22  | 133401  | 94812                                    | 2170   | 3968  | 88674  | 60.3   |
| Sep-22  | 117420  | 82475                                    | 2100   | 3840  | 76535  | 52.0   |
| Oct-22  | 117832  | 91372                                    | 2170   | 3968  | 85234  | 58.0   |
| Nov-22  | 103412  | 81010                                    | 2100   | 3840  | 75070  | 51.0   |
| Dec-22  | 113843  | 90883                                    | 2170   | 3968  | 84745  | 57.6   |

Assumption: - Specific coal consumption: 0.68 Kg/kWh.

Anticipated peak demand is attached as annexure-I.

Annexure-1

| Anticipated demand and source wise resource adequacy from Jan-22 to Dec-22 |        |           |        |           |        |           |        |           |        |           |        |           |        |           |        |           |        |           |        |           |        |           |        | Date: 17/12/21 |  |
|--|--------|-----------|--------|-----------|--------|-----------|--------|-----------|--------|-----------|--------|-----------|--------|-----------|--------|-----------|--------|-----------|--------|-----------|--------|-----------|--------|----------------|--|
| (All values in MW)   |        |           |        |           |        |           |        |           |        |           |        |           |        |           |        |           |        |           |        |           |        |           |        |                |  |
|  | Jan-22 |           | Feb-22 |           | Mar-22 |           | Apr-22 |           | May-22 |           | Jun-22 |           | Jul-22 |           | Aug-22 |           | Sep-22 |           | Oct-22 |           | Nov-22 |           | Dec-22 |                |  |
|  | Solar  | Non-Solar | Solar  | Non-Solar | Solar  | Non-Solar | Solar  | Non-Solar | Solar  | Non-Solar | Solar  | Non-Solar | Solar  | Non-Solar | Solar  | Non-Solar | Solar  | Non-Solar | Solar  | Non-Solar | Solar  | Non-Solar | Solar  | Non-Solar      |  |
| All India demand (A)   | 198888 | 177468    | 196713 | 180335    | 198927 | 181776    | 193633 | 183108    | 207062 | 185515    | 206845 | 201852    | 214474 | 201911    | 210745 | 200195    | 187993 | 178869    | 183859 | 176601    | 166529 | 169127    | 188898 | 179103         |  |
| Time of Occurrence (H)   | 10:15  | 18:45     | 10:15  | 18:45     | 10:15  | 18:45     | 9:15   | 19:15     | 15:00  | 9:15      | 12:30  | 22:15     | 14:30  | 22:30     | 11:00  | 19:45     | 11:45  | 19:15     | 10:30  | 19:15     | 10:30  | 18:30     | 10:30  | 19:00          |  |
| Anticipated losses (B)   | 2000   | 2000      | 2000   | 2000      | 2000   | 2000      | 2000   | 2000      | 2000   | 2000      | 2000   | 2000      | 2000   | 2000      | 2000   | 2000      | 2000   | 2000      | 2000   | 2000      | 2000   | 2000      | 2000   | 2000           |  |
| Total anticipated demand (C = A-B)   | 200888 | 179468    | 200713 | 182335    | 200927 | 183776    | 195633 | 185108    | 209062 | 187515    | 208845 | 203852    | 216474 | 203911    | 212745 | 202195    | 189993 | 180869    | 185859 | 178601    | 168529 | 171127    | 190898 | 181103         |  |
| Nuclear Generation (D)   | 5000   | 5000      | 5000   | 5000      | 5000   | 5000      | 5000   | 5000      | 5000   | 5000      | 5000   | 5000      | 5000   | 5000      | 5000   | 5000      | 5000   | 5000      | 5000   | 5000      | 5000   | 5000      | 5000   | 5000           |  |
| Gas Generation (E)   | 4357   | 4068      | 4428   | 4533      | 5449   | 5754      | 4274   | 4552      | 4057   | 9100      | 4472   | 9100      | 4389   | 9100      | 4698   | 9100      | 4042   | 5293      | 4678   | 5913      | 3117   | 3506      | 3029   | 3172           |  |
| Hydro Generation (F)   | 16921  | 18904     | 14494  | 20908     | 12017  | 20708     | 11003  | 20661     | 10654  | 12777     | 22852  | 29328     | 26767  | 30577     | 28329  | 34894     | 29688  | 34604     | 19160  | 32463     | 12438  | 28210     | 10807  | 22959          |  |
| Wind (G)   | 5998   | 4166      | 2701   | 3365      | 2044   | 4598      | 2472   | 5920      | 8418   | 10338     | 12243  | 13527     | 14898  | 15295     | 11257  | 12374     | 7667   | 10338     | 9025   | 4409      | 3441   | 4274      | 3380   | 4768           |  |
| Solar (H)  | 21550  | 0         | 27466  | 0         | 28717  | 0         | 21481  | 0         | 21689  | 0         | 29151  | 0         | 21969  | 0         | 25512  | 0         | 26976  | 0         | 31623  | 0         | 26448  | 0         | 29239  | 0              |  |
| Other RES (I)  | 3682   | 3682      | 4219   | 4719      | 3539   | 3539      | 2837   | 2837      | 2249   | 2249      | 2003   | 2003      | 2604   | 2604      | 2680   | 2680      | 2854   | 2854      | 2568   | 2568      | 3459   | 3459      | 4318   | 4318           |  |
| Ex-bus Thermal requirement (K = C - D - E - F - G - H - I)                 | 146779 | 143648    | 142406 | 144611    | 144161 | 144177    | 147864 | 146039    | 156295 | 147151    | 132925 | 148994    | 140147 | 140435    | 134568 | 137247    | 119062 | 122110    | 119163 | 127549    | 113886 | 125938    | 134219 | 140920         |  |
| Gross Thermal requirement (J = K * L/D)                                    | 157094 | 153704    | 152374 | 154733    | 154252 | 154269    | 158235 | 156263    | 167230 | 157452    | 142230 | 149074    | 149957 | 150386    | 148988 | 146854    | 127397 | 130657    | 127504 | 136477    | 121858 | 134754    | 148094 | 158404         |  |
| Gross imported coal generation (M)   | 5350   | 5350      | 5350   | 5350      | 5350   | 5350      | 5350   | 5350      | 5350   | 5350      | 5350   | 5350      | 5350   | 5350      | 5350   | 5350      | 5350   | 5350      | 5350   | 5350      | 5350   | 5350      | 5350   | 5350           |  |
| Capacity of imported coal (N)  | 20070  | 20070     | 20070  | 20070     | 20070  | 20070     | 20070  | 20070     | 20070  | 20070     | 20070  | 20070     | 20070  | 20070     | 20070  | 20070     | 20070  | 20070     | 20070  | 20070     | 20070  | 20070     | 20070  | 20070          |  |
| Percentage of Gross Imported/Capacity (O = M/N)                            | 27%    | 27%       | 27%    | 27%       | 27%    | 27%       | 27%    | 27%       | 27%    | 27%       | 27%    | 27%       | 27%    | 27%       | 27%    | 27%       | 27%    | 27%       | 27%    | 27%       | 27%    | 27%       | 27%    | 27%            |  |
| Gross domestic thermal excluding imported coal (P = J - M)                 | 151704 | 148354    | 147024 | 149383    | 148902 | 148919    | 152865 | 150911    | 161886 | 152102    | 136880 | 148724    | 144607 | 144916    | 138638 | 141504    | 125947 | 125307    | 122154 | 131127    | 116508 | 129404    | 138294 | 145114         |  |
| Installed capacity on domestic coal (Q)                                    | 189214 | 189214    | 189214 | 189214    | 189214 | 189214    | 189214 | 189214    | 189214 | 189214    | 189214 | 189214    | 189214 | 189214    | 189214 | 189214    | 189214 | 189214    | 189214 | 189214    | 189214 | 189214    | 189214 | 189214         |  |
| Required coal generation availability (R/Q)                                | 80%    | 78%       | 78%    | 79%       | 79%    | 79%       | 81%    | 80%       | 80%    | 80%       | 72%    | 79%       | 76%    | 77%       | 73%    | 75%       | 65%    | 66%       | 65%    | 69%       | 62%    | 68%       | 73%    | 77%            |  |

**Assumptions:**

- 1) Month wise average growth rate from 2016 to 2021 was calculated (peak day). This growth rate was applied on monthwise peak demand of 2021 to anticipate 2022 demand.
- 2) Transmission losses: 2000MW
- 3) Nuclear generation: Considering present generation, From Apr-22 onward, Kakrapar (2000MW) unit is also considered
- 4) Gas & Hydro generation: Diurnal of each month from (Jan-21 to Dec-21 (upto 16th)) has been utilized.
- 5) Wind/Solar/Other RES Generation forecast:
  - a). Installed capacity growth rate for 10 months (from Jan to Oct-21) has been calculated. (Wind: 1.0034; Solar: 1.0228; Other RES: 1.0024) and same was applied to anticipate monthly installed capacity.
  - b). Diurnal of each month from (Jan-21 to Dec-21 (upto 16th)) has been scaled on the basis of installed capacity of that particular month.
- 6) Imported coal generation: 120MT/day (5000MW - Ex-bus)
- 7) Auxiliary consumption: 7%
- 8) The difference between anticipated total demand and the cumulative generation from nuclear, wind, solar, hydro & gas would be met from thermal (coal) generation.
- 9) Present Installed capacity (Coal+Lignite) - 209284 MW

## Annexure-2

| A. Planned Outages |   |                |                    |         |                  |   |             |       |                  |
|--------------------|---|----------------|--------------------|---------|------------------|---|-------------|-------|------------------|
| Sl. No             | Station                                   | State          | Agency             | Unit No | Capacity<br>(MW) | Reason(s)   | Outage      |       | Expected Revival |
|                    |   |                |                    |         |                  |   | Date        | Time  | Date             |
| 1                  | Shree Cement (IPP) TPS                    | RAJASTHAN      | RRVPL, Sh. Cement  | 1       | 150              | Reserve Shutdown  | 21-Oct-2021 | 23:58 | -                |
| 2                  | Shree Cement (IPP) TPS                    | RAJASTHAN      | RRVPL, Sh. Cement  | 2       | 150              | Reserve Shutdown  | 21-Oct-2021 | 23:59 | -                |
| 3                  | Tanda TPS                                 | UP             | NTPC               | 3       | 110              | Reserve Shutdown  | 23-Oct-2021 | 04:31 | -                |
| 4                  | Dadri-1 TPS                               | DELHI          | NTPC               | 3       | 210              | Reserve Shutdown  | 23-Oct-2021 | 00:00 | -                |
| 5                  | Tanda TPS                                 | UP             | NTPC               | 4       | 110              | Reserve Shutdown  | 23-Oct-2021 | 04:31 | -                |
| 6                  | Tanda TPS                                 | UP             | NTPC               | 1       | 110              | Reserve Shutdown  | 24-Oct-2021 | 17:01 | -                |
| 7                  | Tanda TPS                                 | UP             | NTPC               | 2       | 110              | Reserve Shutdown  | 24-Oct-2021 | 17:01 | -                |
| 8                  | ISTPP (Bhajar)                            | HARYANA        | APCPL              | 1       | 500              | Planned Shutdown for FGD Work   | 18-Dec-2021 | 23:58 | -                |
| 9                  | Panipat TPS                               | HARYANA        | HPGCL              | 6       | 210              | Tariff not approved by HERC   | 23-Jul-2020 | 13:33 | -                |
| 10                 | BETPP (Khadar)                            | HARYANA        | HVPNL              | 2       | 600              | Capital Overhauling/turbine replacement                                 | 02-Mar-2021 | 00:00 | 01-Sep-2022      |
| 11                 | Guru Gobind Singh TPS (Ropar)             | PUNJAB         | PSPCL              | 3       | 210              | Reserve Shutdown  | 27-Aug-2021 | 20:07 | -                |
| 12                 | Guru Gobind Singh TPS (Ropar)             | PUNJAB         | PSPCL              | 5       | 210              | Reserve Shutdown  | 15-Oct-2021 | 06:07 | -                |
| 13                 | Guru Hargobind Singh TPS (Lehra Mohabbat) | PUNJAB         | PSPCL              | 4       | 250              | Reserve Shutdown  | 16-Oct-2021 | 10:06 | -                |
| 14                 | Guru Gobind Singh TPS (Ropar)             | PUNJAB         | PSPCL              | 5       | 210              | Reserve Shutdown  | 16-Oct-2021 | 00:50 | -                |
| 15                 | Guru Hargobind Singh TPS (Lehra Mohabbat) | PUNJAB         | PSPCL              | 1       | 210              | Reserve Shutdown  | 17-Oct-2021 | 11:30 | -                |
| 16                 | Harduaganj-D TPS                          | UP             | UPPTCL             | 8       | 250              | Reserve shutdown  | 17-Oct-2021 | 21:15 | -                |
| 17                 | Harduaganj-D TPS                          | UP             | UPPTCL             | 9       | 250              | Reserve shutdown  | 17-Oct-2021 | 21:08 | -                |
| 18                 | Rose TPS                                  | UP             | UPPTCL             | 3       | 300              | Reserve Shutdown  | 22-Oct-2021 | 11:16 | -                |
| 19                 | Rose TPS                                  | UP             | UPPTCL             | 4       | 300              | Reserve Shutdown  | 22-Oct-2021 | 20:32 | -                |
| 20                 | Harduaganj-C TPS                          | UP             | UPPTCL             | 7       | 110              | Reserve Shutdown  | 25-Oct-2021 | 23:01 | -                |
| 21                 | Rajpura (NPL) TPS                         | PUNJAB         | PSTCL, PSPCL       | 2       | 700              | Over hauling  | 15-Nov-2021 | 16:44 | -                |
| 22                 | Bawana GPS                                | DELHI          | DTL/Pragati COGT   | 2       | 216              | Reserve Shutdown  | 21-Nov-2021 | 14:25 | -                |
| 23                 | Guru Hargobind Singh TPS (Lehra Mohabbat) | PUNJAB         | PSPCL              | 3       | 250              | Reserve Shutdown DUE TO LESS DEMAND                                     | 18-Dec-2021 | 17:55 | -                |
| 24                 | Suratgarh TPS                             | RAJASTHAN      | RRVPL              | 3       | 250              | Reserve Shutdown  | 18-Dec-2021 | 19:13 | -                |
| 25                 | ESSAR(MAHAN)                              | MADHYA PRADESH | Essar Mahan (EPMP) | 2       | 600              | withdrawn on BTL  | 14-Dec-2021 | 09:39 | -                |
| 26                 | KSTPS                                     | CHHATTISGARH   | NTPC               | 2       | 200              | AOH   | 02-Dec-2021 | 01:00 | 25-Dec-2021      |
| 27                 | VSTPS IV                                  | MADHYA PRADESH | NTPC               | 1       | 500              | AOH   | 02-Dec-2021 | 00:24 | 05-Jan-2022      |
| 28                 | MOUDA I                                   | MAHARASHTRA    | NTPC               | 2       | 500              | AOH   | 17-Nov-2021 | 00:17 | 28-Dec-2021      |
| 29                 | GADARKWARA                                | MADHYA PRADESH | NTPC               | 1       | 800              | overhauling works   | 15-Nov-2021 | 00:11 | 20-Dec-2021      |
| 30                 | JPL STG-I                                 | CHHATTISGARH   | Jindal power (JPL) | 3       | 250              | Low Export Schedule./Less Schedule                                      | 01-Nov-2021 | 00:00 | 25-Dec-2021      |
| 31                 | SIPATI                                    | CHHATTISGARH   | NTPC               | 1       | 660              | Due high vibration in turbine bearing/converted to AOH since 30/10/2021 | 28-Oct-2021 | 10:41 | 28-Dec-2021      |
| 32                 | NASIK                                     | MAHARASHTRA    | Maharashtra        | 4       | 210              | RSD/RSD   | 11-Dec-2021 | 21:22 | -                |
| 33                 | AECO-B                                    | GUJARAT        | Gujarat            | 1       | 120              | AOH   | 10-Dec-2021 | 00:00 | -                |
| 34                 | TROMBAY                                   | MAHARASHTRA    | Maharashtra        | 8       | 250              | AOH   | 06-Dec-2021 | 00:02 | 02-Jan-2022      |
| 35                 | JAIGAD                                    | MAHARASHTRA    | Maharashtra        | 2       | 300              | RSD/RSD   | 19-Nov-2021 | 01:26 | -                |
| 36                 | SCPL                                      | CHHATTISGARH   | ACBIL              | 2       | 50               | AOH   | 15-Nov-2021 | 23:55 | -                |
| 37                 | APL MUNDRA                                | GUJARAT        | Gujarat            | 5       | 660              | RSD/RSD   | 04-Nov-2021 | 13:30 | -                |
| 38                 | APL MUNDRA                                | GUJARAT        | Gujarat            | 6       | 660              | RSD/RSD   | 04-Nov-2021 | 00:36 | -                |
| 39                 | MAKWA TPS                                 | CHHATTISGARH   | Chattisgarh        | 1       | 500              | AOH   | 02-Nov-2021 | 00:00 | 31-Dec-2021      |
| 40                 | WANAKBORI                                 | GUJARAT        | Gujarat            | 6       | 210              | COH   | 15-Jun-2021 | 00:00 | 22-Dec-2021      |
| 41                 | KITPS                                     | GUJARAT        | Gujarat            | 4       | 75               | tripped on Drum level high, converted to AOH since 09-06-2021           | 05-Jun-2021 | 06:23 | 15-Jan-2022      |
| 42                 | VIPL                                      | MAHARASHTRA    | Maharashtra        | 2       | 300              | Unit as out on Coal Shortage. Converted to No PPA from 28.05.2019       | 17-Jan-2019 | 00:15 | -                |
| 43                 | VIPL                                      | MAHARASHTRA    | Maharashtra        | 1       | 300              | Unit as out on Coal Shortage. Converted to No PPA from 28.05.2019       | 29-Dec-2018 | 00:30 | -                |
| 44                 | WFCL                                      | MAHARASHTRA    | Maharashtra        | 1       | 135              | Unit out of service as no PPA   | 25-Nov-2018 | 04:48 | -                |
| 45                 | IEPL                                      | MAHARASHTRA    | IEPL               | 1       | 270              | No PPA.   | 28-Aug-2018 | 21:26 | -                |

|   |                               |                |             |    |       |  |             |       |   |
|---|-------------------------------|----------------|-------------|----|-------|--|-------------|-------|---|
| 46  | PIONEER(2624-127)             | MAHARASHTRA    | Maharashtra | 1  | 388   | No PPA zero schedule   | 07-Feb-2017 | 17:45 | - |
| 47  | SIMHAPURI ENERGY PVT LTD      | ANDHRA PRADESH | SEPL        | 1  | 150   | PPA Pending with APDISCOMs   | 18-Mar-2017 | 00:08 |   |
| 48  | SIMHAPURI ENERGY PVT LTD      | ANDHRA PRADESH | SEPL        | 4  | 150   | PPA Pending with APDISCOMs   | 07-Apr-2017 | 05:25 |   |
| 49  | MEENAKSHI ENERGY LTD          | ANDHRA PRADESH | MEL         | 3  | 350   | Under S/D due to NCLT  | 03-May-2018 | 00:45 |   |
| 50  | SIMHAPURI ENERGY PVT LTD      | ANDHRA PRADESH | SEPL        | 2  | 150   | PPA Pending with APDISCOMs   | 27-May-2018 | 11:06 |   |
| 51  | SIMHAPURI ENERGY PVT LTD      | ANDHRA PRADESH | SEPL        | 3  | 150   | PPA Pending with APDISCOMs   | 27-May-2018 | 03:01 |   |
| 52  | MEENAKSHI ENERGY LTD          | ANDHRA PRADESH | MEL         | 4  | 350   | Under S/D due to NCLT  | 11-Apr-2019 | 20:51 |   |
| 53  | KUDGI                         | KARNATAKA      | NTPC_KUDGI  | 1  | 800   | ANNUAL OVERHAULING   | 01-Aug-2021 | 00:01 |   |
| 54  | IL&FS                         | TAMILNADU      | IL&FS       | 1  | 600   | Payment Related issues   | 10-Oct-2021 | 02:28 |   |
| 55  | SEIL-PROJECT2                 | ANDHRA PRADESH | SEIL        | 1  | 660   | CAPITAL OVERHAULING (5 YEARS ONCE)   | 17-Nov-2021 | 23:59 |   |
| 56  | RAMAGUNDAM                    | TELANGANA      | NTPC_RSTPS  | 4  | 500   | OVER HAULING   | 02-Dec-2021 | 23:40 |   |
| 57  | HINDUJA POWER CORPORATION LTD | ANDHRA PRADESH | HINDUJA     | 2  | 520   | Dispute in PPA by APDISCOMs  | 16-Jul-2020 | 04:00 |   |
| 58  | HINDUJA POWER CORPORATION LTD | ANDHRA PRADESH | HINDUJA     | 1  | 520   | Dispute in PPA by APDISCOMs  | 18-Jul-2020 | 14:15 |   |
| 59  | UPCL                          | KARNATAKA      | ADANI       | 2  | 600   | RSD  | 27-Aug-2021 | 21:49 |   |
| 60  | UPCL                          | KARNATAKA      | ADANI       | 1  | 600   | RSD  | 27-Aug-2021 | 22:31 |   |
| 61  | TUTICORIN                     | TAMILNADU      | TANGEDCO    | 1  | 210   | CAPITAL OVERHAUL WORKS   | 04-Nov-2021 | 09:14 |   |
| 62  | BELLARY TPS                   | KARNATAKA      | KPCL        | 2  | 500   | LOW DEMAND   | 09-Nov-2021 | 11:43 |   |
| 63  | KRISHNAPATTANAM               | ANDHRA PRADESH | APGENCO     | 3  | 800   | H/T after FTC  | 10-Nov-2021 | 19:08 |   |
| 64  | RAICHUR TPS                   | KARNATAKA      | KPCL        | 3  | 210   | Low Demand   | 13-Nov-2021 | 21:11 |   |
| 65  | RAICHUR TPS                   | KARNATAKA      | KPCL        | 4  | 210   | RSD  | 25-Nov-2021 | 11:22 |   |
| 66  | KRISHNAPATTANAM               | ANDHRA PRADESH | APGENCO     | 1  | 800   | ANNUAL OVERHAULING   | 01-Dec-2021 | 16:29 |   |
| 67  | VIJAYAWADA TPS                | ANDHRA PRADESH | APGENCO     | 3  | 210   | Annual Overhauling   | 03-Dec-2021 | 22:38 |   |
| 68  | VIJAYAWADA TPS                | ANDHRA PRADESH | APGENCO     | 8  | 800   | H/T after FTC  | 07-Dec-2021 | 01:10 |   |
| 69  | KOTHAGUDEM TPS                | TELANGANA      | TELANGANA   | 11 | 500   | for capital over haul  | 08-Dec-2021 | 14:54 |   |
| 70  | NORTH CHENNAI TPS             | TAMILNADU      | TANGEDCO    | 1  | 210   | ANNUAL OVERHAULING   | 14-Dec-2021 | 04:00 |   |
| 71  | DARLIPALI                     | ODISHA         | NTPC        | 1  | 800   | ANNUAL OVERHAULING   | 25-Nov-2021 | 01:34 |   |
| 72  | TSTPP                         | ODISHA         | NTPC        | 3  | 500   | ANNUAL OVERHAULING   | 04-Dec-2021 | 18:14 |   |
| 73  | BARAUNI TPS                   | BIHAR          | BSPHCL      | 7  | 110   | RSD/ LOW SYSTEM DEMAND   | 29-Oct-2021 | 00:00 |   |
| 74  | KOLAGHAT                      | WEST BENGAL    | WBPUCL      | 1  | 210   | Initially taken under ESP R & M. Presently Under consideration for De-commissioning. | 07-Jun-2018 | 23:05 |   |
| 75  | MUZAFFARPUR TPS               | BIHAR          | BSPHCL      | 1  | 110   | Completion of tenure of PPA  | 08-Sep-2021 | 00:00 |   |
| 76  | MUZAFFARPUR TPS               | BIHAR          | BSPHCL      | 2  | 110   | Completion of tenure of PPA  | 08-Sep-2021 | 00:00 |   |
| Total Capacity under planned outage ( MW) |                               |                |             |    | 26304 |  |             |       |   |

### B. Forced Outages

| Sl. No | Station            | State     | Agency           | Unit No | Capacity (MW) | Reason(s)   | Outage      |       | Expected Revival |
|--------|--------------------|-----------|------------------|---------|---------------|---|-------------|-------|------------------|
|        |                    |           |                  |         |               |   | Date        | Time  | Date             |
| 1      | Tanda TPS          | UP        | NTPC             | 5       | 660           | Generator Fault electrical fault  | 22-Dec-2021 | 20:57 | -                |
| 2      | Chhabra TPS        | RAJASTHAN | RRVNL            | 4       | 250           | Due to ESP structure damage   | 09-Sep-2021 | 00:47 | -                |
| 3      | Anpara TPS         | UP        | UPPTCL           | 2       | 210           | due to turbine oil leakage  | 18-Nov-2021 | 03:50 | -                |
| 4      | Rajwest (IPP) LTPS | RAJASTHAN | RRVNL            | 4       | 135           | BED MATERIAL LEAKAGE  | 19-Nov-2021 | 02:42 | -                |
| 5      | Bawana GPS         | DELHI     | DTL/Pragati CCGT | 3       | 216           | Reserve Shutdown  | 28-Nov-2021 | 10:03 | -                |
| 6      | Suratgarh TPS      | RAJASTHAN | RRVNL            | 2       | 250           | Due to a problem in the PLC System of Wet Evacuation of ESP Hoppers, it is not possible to evacuate Ash from ESP Hoppers. | 30-Nov-2021 | 03:06 | -                |
| 7      | Rajwest (IPP) LTPS | RAJASTHAN | RRVNL            | 3       | 135           | DUE TO GENERATOR TRIP   | 13-Dec-2021 | 12:32 | -                |
| 8      | Anpara-C TPS       | UP        | UPPTCL/LANCO     | 1       | 600           | Boiler tube leakage   | 17-Dec-2021 | 18:55 | -                |
| 9      | Obra TPS           | UP        | UPPTCL           | 13      | 200           | ICT rear bearing vibration high   | 18-Dec-2021 | 04:00 | -                |
| 10     | Rajwest (IPP) LTPS | RAJASTHAN | RRVNL            | 8       | 135           | HEAVY BED MATERIAL LEAKAGE  | 19-Dec-2021 | 19:58 | -                |
| 11     | Talwandi Sabo TPS  | PUNJAB    | PSTCL/PSPCL      | 2       | 660           | Abnormal sound in boiler  | 21-Dec-2021 | 01:00 | -                |
| 12     | Obra TPS           | UP        | UPPTCL           | 10      | 200           | Due to overspeed of turbine.  | 21-Dec-2021 | 12:41 | -                |
| 13     | Kota TPS           | RAJASTHAN | RRVNL            | 4       | 210           | DUE TO BTL  | 22-Dec-2021 | 12:22 | -                |
| 14     | Obra TPS           | UP        | UPPTCL           | 22      | 200           | TRIPPED DUE TO FURNACE PRESSURE HIGH  | 22-Dec-2021 | 23:34 | 23-Dec-2021      |



|    |                      |                |                     |   |     |   |             |       |             |
|----|----------------------|----------------|---------------------|---|-----|---|-------------|-------|-------------|
| 15 | REL                  | CHHATTISGARH   | REL                 | 1 | 685 | Tripped due to HP Bypass CV-2 Fail  | 22-Dec-2021 | 19:49 | -           |
| 16 | RKM POWER            | CHHATTISGARH   | RKM                 | 3 | 360 | Withdrawn due to vacuum pump issue  | 17-Dec-2021 | 21:54 | -           |
| 17 | JPL STG-II           | CHHATTISGARH   | Jindal power JPLI   | 4 | 600 | APH Gear box Problem  | 12-Dec-2021 | 00:00 | -           |
| 18 | SXS POWER            | CHHATTISGARH   | SXS                 | 2 | 300 | Tripped due to stalling of APH B  | 21-Nov-2021 | 06:04 | 31-Jan-2022 |
| 19 | CGPL                 | GUJARAT        | CGPL                | 4 | 830 | Fault in R-ph GT  | 21-Nov-2021 | 09:42 | -           |
| 20 | CGPL                 | GUJARAT        | CGPL                | 1 | 830 | Due to HP turbine warm up line NRV passing./ outage reason converted to high coal price since 22/10/2021  | 17-Oct-2021 | 02:18 | -           |
| 21 | TRN ENERGY           | CHHATTISGARH   | TRN                 | 1 | 300 | Due to flame failure / coal shortage/Coal Shortage  | 02-Sep-2021 | 02:58 | -           |
| 22 | TRN ENERGY           | CHHATTISGARH   | TRN                 | 2 | 300 | due to high vibration in the TURBINE  | 10-Mar-2021 | 12:54 | -           |
| 23 | TARAPUR I            | MAHARASHTRA    | NPCIL               | 2 | 160 | For cleaning of clogged basket strainer of cooling water system due to heavy ingress of debris from sea. The outage extended for repair and re-fuelling.  | 13-Jul-2020 | 04:38 | 30-Mar-2022 |
| 24 | SLPP                 | GUJARAT        | Gujarat             | 1 | 125 | BTL   | 18-Dec-2021 | 19:17 | -           |
| 25 | ALTPS                | GUJARAT        | Gujarat             | 2 | 125 | Tripped, bus bar protection operated due to malfunctioning in bus coupler relay   | 17-Dec-2021 | 12:40 | -           |
| 26 | JP BINA              | MADHYA PRADESH | Madhya Pradesh      | 1 | 250 | Coal Shortage/Coal Shortage   | 17-Dec-2021 | 23:56 | -           |
| 27 | ALTPS                | GUJARAT        | Gujarat             | 1 | 125 | BTL   | 16-Dec-2021 | 17:20 | -           |
| 28 | KHAPARKHEDA          | MAHARASHTRA    | Maharashtra         | 3 | 210 | withdrawn due to non availability of conveyor belt  | 09-Dec-2021 | 00:00 | -           |
| 29 | KHAPARKHEDA          | MAHARASHTRA    | Maharashtra         | 1 | 210 | withdrawn due to non availability of conveyor belt  | 09-Dec-2021 | 00:56 | -           |
| 30 | KHAPARKHEDA          | MAHARASHTRA    | Maharashtra         | 2 | 210 | withdrawn due to non availability of conveyor belt  | 09-Dec-2021 | 01:49 | -           |
| 31 | KHAPARKHEDA          | MAHARASHTRA    | Maharashtra         | 4 | 210 | withdrawn due to non availability of conveyor belt  | 08-Dec-2021 | 21:00 | -           |
| 32 | UKAI                 | GUJARAT        | Gujarat             | 3 | 200 | Turbine vibration high  | 19-Nov-2021 | 01:54 | -           |
| 33 | STPS                 | GUJARAT        | Gujarat             | 3 | 250 | Coal feeding problem  | 18-Sep-2021 | 13:31 | -           |
| 34 | SINGAJI              | MADHYA PRADESH | Madhya Pradesh      | 4 | 660 | Tripped due to fire caught near mill aide/ converted to coal shortage since 27/09/2021/Coal Shortage  | 16-Sep-2021 | 16:46 | -           |
| 35 | JAIGAD               | MAHARASHTRA    | Maharashtra         | 1 | 300 | Due to turbine vibration high   | 02-Sep-2021 | 08:41 | 26-Dec-2021 |
| 36 | STPS                 | GUJARAT        | Gujarat             | 4 | 250 | Due to HVBP system problem. Reason changed to coal feeding problem from 10:30 hrs/ 18.09.2021   | 01-Sep-2021 | 08:25 | -           |
| 37 | APL MUNDRA           | GUJARAT        | Gujarat             | 9 | 660 | Depletion of Coal Stock and unaffordable cost of generation./Coal Shortage  | 25-Aug-2021 | 02:33 | -           |
| 38 | OPGS                 | GUJARAT        | Gujarat             | 1 | 150 | Tripped due to tripping of GT due to LA failure/ converted to coal shortage/Converted to commercial reason due to costly coal   | 10-Aug-2021 | 04:47 | -           |
| 39 | APL MUNDRA           | GUJARAT        | Gujarat             | 8 | 660 | COH. converted to coal shortage from 02.09.2021.(Depletion of Coal Stock and unaffordable cost of generation./Coal Shortage   | 19-Jul-2021 | 00:00 | -           |
| 40 | SATPURA II           | MADHYA PRADESH | Madhya Pradesh      | 7 | 210 | UNIT UNDER FORCED OUTAGE DUE TO CONSIDERATION OF RETIREMENT BY MP GOVT  | 08-Jul-2021 | 12:42 | -           |
| 41 | SATPURA II           | MADHYA PRADESH | Madhya Pradesh      | 6 | 200 | UNIT UNDER FORCED OUTAGE DUE TO CONSIDERATION OF RETIREMENT BY MP GOVT  | 08-Jul-2021 | 12:42 | -           |
| 42 | OPGS                 | GUJARAT        | Gujarat             | 2 | 150 | Technical problem/ converted to coal shortage/Converted to commercial reason due to costly coal   | 06-Jun-2021 | 01:18 | -           |
| 43 | APL MUNDRA           | GUJARAT        | Gujarat             | 7 | 660 | Due to abnormal sound coming from APH-7A and oil leakage from gear box. Converted to Coal Shortage from 16.07.2021. (Depletion of Coal Stock and unaffordable cost of generation./Coal Shortage | 06-May-2021 | 08:01 | -           |
| 44 | VADINAR              | GUJARAT        | Essar Mahan (EPMDL) | 2 | 600 | Coal Shortage/Coal Shortage   | 11-Mar-2021 | 10:17 | -           |
| 45 | VADINAR              | GUJARAT        | Essar Mahan (EPMDL) | 1 | 600 | Coal Shortage   | 15-Dec-2020 | 12:30 | -           |
| 46 | SATPURA II           | MADHYA PRADESH | Madhya Pradesh      | 3 | 210 | reheater tube leakage   | 29-Feb-2020 | 23:54 | -           |
| 47 | SATPURA II           | MADHYA PRADESH | Madhya Pradesh      | 4 | 210 | BTL   | 22-Feb-2020 | 02:52 | -           |
| 48 | MEENAKSHI ENERGY LTD | ANDHRA PRADESH | MEL                 | 1 | 150 | boiler MFT trip   | 16-Jul-2021 | 05:36 | -           |
| 49 | MEENAKSHI ENERGY LTD | ANDHRA PRADESH | MEL                 | 2 | 150 | BOILER MFT  | 29-Jul-2021 | 00:22 | -           |
| 50 | COASTAL ENERGY       | TAMILNADU      | COASTAL ENERGEN     | 1 | 600 | turbine stop-valve problem  | 22-Oct-2021 | 00:20 | -           |
| 51 | NEVELI TS II         | TAMILNADU      | NLC                 | 6 | 210 | WATER VALVE PUNCTURE  | 24-Nov-2021 | 08:42 | -           |
| 52 | NEVELI TS II         | TAMILNADU      | NLC                 | 3 | 210 | DUE TO WET LIGNITE  | 26-Nov-2021 | 00:44 | -           |
| 53 | RAMAGUNDAM           | TELANGANA      | NTPC_RSTPS          | 3 | 200 | BOILER TUBE LEAKAGE   | 21-Dec-2021 | 08:31 | -           |

|  |                          |                |            |   |       |   |             |       |
|--|--------------------------|----------------|------------|---|-------|---|-------------|-------|
| 54                                       | VALLUR TPS               | TAMILNADU      | NTECL      | 1 | 500   | loss of excitation  | 22-Dec-2021 | 17:23 |
| 55                                       | RAMAGUNDAM               | TELANGANA      | NTPC_RSTPS | 5 | 500   | Boiler Tube Leakage   | 22-Dec-2021 | 11:59 |
| 56                                       | BHADRADRI TPS            | TELANGANA      | TSGENCO    | 4 | 270   | H/T AFTER FIC   | 13-Oct-2021 | 21:54 |
| 57                                       | JINDAL                   | KARNATAKA      | JINDAL     | 4 | 300   | NO SCHEDULE   | 06-Nov-2021 | 20:29 |
| 58                                       | JINDAL                   | KARNATAKA      | JINDAL     | 2 | 130   | NO SCHEDULE   | 25-Nov-2021 | 10:40 |
| 59                                       | SEPC                     | TAMILNADU      | TANGEDCO   | 1 | 525   | Due to Boiler MFT   | 30-Nov-2021 | 21:59 |
| 60                                       | METTUR TPS               | TAMILNADU      | TANGEDCO   | 3 | 210   | H/T for conservation of coal  | 04-Dec-2021 | 19:04 |
| 61                                       | VIJAYAWADA TPS           | ANDHRA PRADESH | APGENCO    | 7 | 500   | TRIPPED ON ELECTRICAL FAULT   | 09-Dec-2021 | 19:20 |
| 62                                       | RAVALASEEMA TPP          | ANDHRA PRADESH | APGENCO    | 3 | 210   | GT BUCHHLDZ RELAY OPERATED  | 17-Dec-2021 | 02:15 |
| 63                                       | NORTH CHENNAI TPS STG-II | TAMILNADU      | TANGEDCO   | 4 | 600   | PA FAN PROBLEM  | 18-Dec-2021 | 03:36 |
| 64                                       | METTUR TPS               | TAMILNADU      | TANGEDCO   | 2 | 210   | BOILER TUBE LEAKAGE   | 22-Dec-2021 | 23:12 |
| 65                                       | BARH                     | BIHAR          | NTPC       | 4 | 660   | STL   | 22-Dec-2021 | 13:45 |
| 66                                       | TSTPP                    | ODISHA         | NTPC       | 2 | 500   | BOILER TUBE LEAKAGE   | 19-Dec-2021 | 22:27 |
| 67                                       | BARAJUNI TPS             | BIHAR          | BSPHCL     | 6 | 110   | ABNCRMAL TSI PARAMETER  | 17-Mar-2021 | 19:29 |
| 68                                       | KODERMA                  | DVC            | DVC        | 1 | 500   | LSD   | 16-Dec-2021 | 13:17 |
| 69                                       | KOLAGHAT                 | WEST BENGAL    | WBPDCL     | 2 | 210   | Initially taken under ESP & Ash Handling R & M. Presently Under consideration for De-commissioning. | 26-Jun-2021 | 22:48 |
| 70                                       | KOLAGHAT                 | WEST BENGAL    | WBPDCL     | 6 | 210   | Due to Drum level very high. Now machine is in boxup condition due to empty Sunker.                 | 12-Dec-2021 | 09:28 |
| 71                                       | MEJIA TPS                | DVC            | DVC        | 1 | 210   | Suspected STL   | 14-Dec-2021 | 12:51 |
| 72                                       | OPGC                     | ODISHA         | OPGC       | 4 | 660   | BOILER TUBE LEAKAGE   | 19-Dec-2021 | 22:23 |
| 73                                       | Sterlite                 | ODISHA         | SEL        | 1 | 600   | Air Pre-heater problem  | 22-Dec-2021 | 22:47 |
| 74                                       | Sterlite                 | ODISHA         | SEL        | 3 | 600   | ASH HANDLING PROBLEM  | 08-Dec-2021 | 02:42 |
| 75                                       | WARIA TPS                | DVC            | DVC        | 4 | 210   | Condensar Tube Leakage  | 15-Oct-2021 | 11:30 |
| Total Capacity under forced outage ( MW) |                          |                |            |   | 25806 |   |             |       |



### **Section-III:**

#### **Concerns related to resource adequacy:**

Based on the above exercise to meet high electricity demand in upcoming months without any constraints, the following are mentioned:

1. Till now, maximum thermal generation (ex-bus) touched 146GW (on 11/04/21). As indicated in resource adequacy table at annexure-1, it is anticipated that thermal generation (based on domestic coal) would be required in the range of 165-167GW (86 % of total installed domestic coal based thermal capacity).
2. To maintain 2% spinning reserves, requirement of on bar capacity would further increase to 171GW, which is 88% of total thermal capacity based on domestic coal). So, the availability of coal fired units and gas fired units with sufficient fuel stocks (as per CEA norms) is vital to meet the peak demand in the upcoming summer months especially during non-solar hours.
3. As on dt. 22.12.21, 52GW capacity is under outages due to various reasons. List attached as annexure-2. Proper monitoring of the same is required in consultation with stake holders, so that reliable and dependable thermal unit's availability can be worked out for each month to ensure resource adequacy in respective regions.
4. All generating stations in respective regions should be advised to carryout periodical testing of Units under RSD to ensure the availability and dependability of the same at all times.
5. Gas based power plants are having high ramping capability and can be brought on bar on short notice so that as and when all India demand surpasses 195GW these units should be on bar on the request without any delay. Therefore, gas plants may be advised to ensure the units availability and adequate fuel (preferably APM/RLNG) may also be tied up in time.

CENTRAL POWER RESEARCH INSTITUTE  
CABLES & DIAGNOSTICS DIVISION  
P.B. No. 8066, SADASHIVANAGAR SUB P.O  
PROF. SIR. C. V. RAMAN ROAD, BANGALORE - 560 080. INDIA.  
Tel: +91 80-22072333/2332



FINAL REPORT

Sub: Consultancy Assignment for Analysis and Submitting the Report on Transformers and Reactors (89 Nos.) of POWERGRID by CPRI, Bangalore

Ref: No. SRTS-H/C&M/WC-2183/LOA-2051/2019/3212 dated 20.03.2019

Date: 04.07.2019

Condition Assessment of Jeypore ICT-I Unit-II

Make: BHEL, Equipment Sl. No. 6004861, Rating: 400/220/33 kV, 105 MVA, Phase: 1 Phase  
Year of Manufacturing: 1987 (32 Years old)

The diagnostic test data provided by POWERGRID have been analysed in detail and following are our observations:

1. IR and Tan delta values of windings are in normal range.
2. Core insulation resistance value obtained between CC & G is 0 MΩ indicating inadvertent core grounding.
3. Moisture content in the solid insulation is normal.
4. Tan delta values of the HV, IV and LV bushings are in normal range.
5. The oil test results are satisfactory.
6. DGA results indicates increasing trend in H<sub>2</sub> gas concentration. This may be attributed to low energy partial discharge.
7. Furan analysis shows normal deterioration of solid insulation.
8. Review of maintenance and equipment history indicates repeated H<sub>2</sub> violation in 2014 and 2018. Review of voltage and load profile shows that autotransformer is experiencing maximum overloading 150% of its rated capacity.

**Recommendations:**

In view of increasing trend in the H<sub>2</sub> gas indicating low energy partial discharge, inadvertent core grounding and voltage and load profile data it can be inferred that the condition of the equipment is critical.

In view of the age of the unit, above mentioned issues and for high power system reliability, the unit is recommended for replacement.

  
(K. P. MEENA)  
JOINT DIRECTOR/HoD (CDD)

FINAL REPORT

Sub: Consultancy Assignment for Analysis and Submitting the Report on Transformers and Reactors (89 Nos.) of POWERGRID by CPRI, Bangalore

Ref: No. SRTS-II/C&M/WC-2183/LOA-2051/2019/3212 dated 20.03.2019

Date: 04.07.2019

Condition Assessment of Rengali ICT-II

Make: BHEL. Equipment Sl. No., 6004865, Rating: 400/220/33 kV, 315 MVA, Phase: 3 Phase  
Year of Manufacturing: 1987 (32 Years old)

The diagnostic test data provided by POWERGRID have been analysed in detail and following are our observations:

1. IR values are relatively lower. Tan delta values of windings are slightly high but in normal range.
2. Core insulation resistance values are normal.
3. Estimated moisture content in the solid insulation in 2.7% exceeding the maximum permissible range. Oil conductivity obtained from FDS data is also high.
4. Tan delta values of the HV, IV and LV bushings are in normal range.
5. The oil test results show low BDV and high water content in oil.
6. D.G.A results are normal indicating healthy internal condition of the transformer.
7. Furan analysis shows normal deterioration of solid insulation.
8. Review of maintenance and equipment history indicates the autotransformer has undergone major overhauling including replacement of all gaskets to address the perennial oil leakage issues. Review of voltage and load profile shows that autotransformer is not loaded to its rated capacity.

Recommendations:

From the diagnostic test data it can be inferred that the condition of the autotransformer is critical. Considering the age of the equipment and for high system reliability, the unit is recommended for replacement.

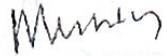
  
(K. P. MEENA)  
JOINT DIRECTOR/InD (CDD)

Member may approve early upgradation of 50MVA ICT with 160 MVA ICT at Malda substation against the schedule of **February 2020**.

TCC may approve.

### **Deliberation in the TCC Meeting**

*TCC approved the preponement of commissioning of 160 MVA ICT-IV of Malda S/S against the schedule of February 2020.*

*TCC referred to ERPC for final approval.*

|                      |  |
|----------------------|--|
| <b>ITEM NO. B22:</b> | <b>Long Outage of main Bay of 400KV Indravati (PG)-Indravati (OHPC) at Indravati (PG) Substation</b> |
|----------------------|--|

The main Bay of 400KV Indravati (PG)-Indravati (OHPC) line at Indravati (PG) S/s belonging to OPTCL, is out of service since 29<sup>th</sup> Sept 2018 for replacement of new CB and CT. Although work by OPTCL was started, it is very slow and completely stopped since March'19. Due to non-availability of this bay, ERLDC is not permitting bay maintenance of other POWERGRID circuits i.e. 400KV Indravati-Rengali and 400KV Indravati-Jeypore lines.

OPTCL is requested to expedite the restoration work of the bay and complete the same at the earliest.

OPTCL may update.

### **Deliberation in the TCC Meeting**

*OPTCL informed that the restoration work of the bay would be completed by December 2019.*

|                      |  |
|----------------------|--|
| <b>ITEM NO. B23:</b> | <b>Replacement of ICT/Reactor in service for more than 25 Years of age</b> |
|----------------------|--|

Many of Transformers and Reactors in POWERGRID system, are in service for more than 25 years and have completed their useful lives. The condition assessment of these transformers and reactors was carried out by POWERGRID and 11 nos. in ER were found critical based on evaluation of ICT results.

Test results and other parameters of these 11 nos. transformer/reactors have been forwarded for residual life assessment (RLA) studies which are being conducted by CPRI. In case, CPRI recommends replacement of these transformers/reactors, POWERGRID shall approach CERC for their replacement under O&M add Cap.

In case of replacement, following has been proposed by Powergrid:

- i) As power transfer through ICTs is continuously increasing and at almost all of the substations, 500MVA, 400/220kV transformers are generally being installed presently. It



is proposed that wherever replacement of old 315 MVA ICT is required, same shall be replaced by 500MVA ICTs to meet future requirements.

- ii) Further, as grid has grown very large, nowadays 125 MVAR Bus Reactors are mostly being installed to control Bus Voltage. It is proposed that wherever replacement of old 50/63/80 MVAR Bus Reactor is required, same shall be replaced by 125 MVAR reactor for better voltage control/reactive power support

TCC may deliberate and decide.

### **Deliberation in the TCC Meeting**

*TCC decided the followings:*

1. *Whenever replacement of old 50/63/80 MVAR Bus Reactor is required the same should be replaced with 125 MVAR bus reactor.*
2. *Whenever replacement of old 315 MVA ICTs is required, the same should be considered for replacement with 500 MVA ICTs based on the requirement analysis on case-to-case basis.*

|                      |  |
|----------------------|--|
| <b>ITEM NO. B24:</b> | <b>Repeated Uncoordinated Trippings at 220 / 132 kV Lalmatia S/stn vis – a – vis Handing over of O&amp;M Services and Assets of 220 kV Farakka – Lalmatia (FLTS) of ECL from NTPC to JUSNL</b> |
|----------------------|--|

In view of uncoordinated trippings and frequent interruption of Power Supply at 220 / 132 kV Lalmatia S/stn, Protection Audit was carried out by ERPC team on 16.08.2018, which recommended considerable investment for replacement of equipment to dovetail with modern Protection System.

Initially ECL had filed a writ petition in the Hon'ble High Court of Calcutta bearing no. W.P. 17044(W) of 2015. Hon'ble High Court of Calcutta passed a judgement dated 23.09.2016 directing NTPC Ltd. to continue the O&M of 220kV Farakka-Lalmatia Transmission system till the lawful transfer of asset and O&M activity of FLTS to any authority. Aggrieved by this judgement, NTPC Ltd filed an appeal bearing no. C.A.N. No. 11255 of 2016 in Hon'ble High Court of Calcutta requesting for stay of the said judgement.

Pending the above appeal by NTPC Ltd., a series of meetings on the issue were held at ERPC as well as JUSNL headquarters.

During deliberation in the 40th TCC Meeting held at Jodhpur on 15.03.2019, ECL representative proposed to handover the ownership of FLTS to JUSNL at zero cost on as-is-where-basis provided necessary investment for up-gradation as recommended by protection audit of ERPC are made by JUSNL and JUSNL ensures uninterrupted supply of power to ECL coal mines at Lalmatia.

JUSNL agreed to look into this proposal and ensured to convey their acceptance after consulting the higher authorities.

## EVENT OF SMELTER LOAD TRIPPING ON 28<sup>th</sup> September

### Sterlite SLD:

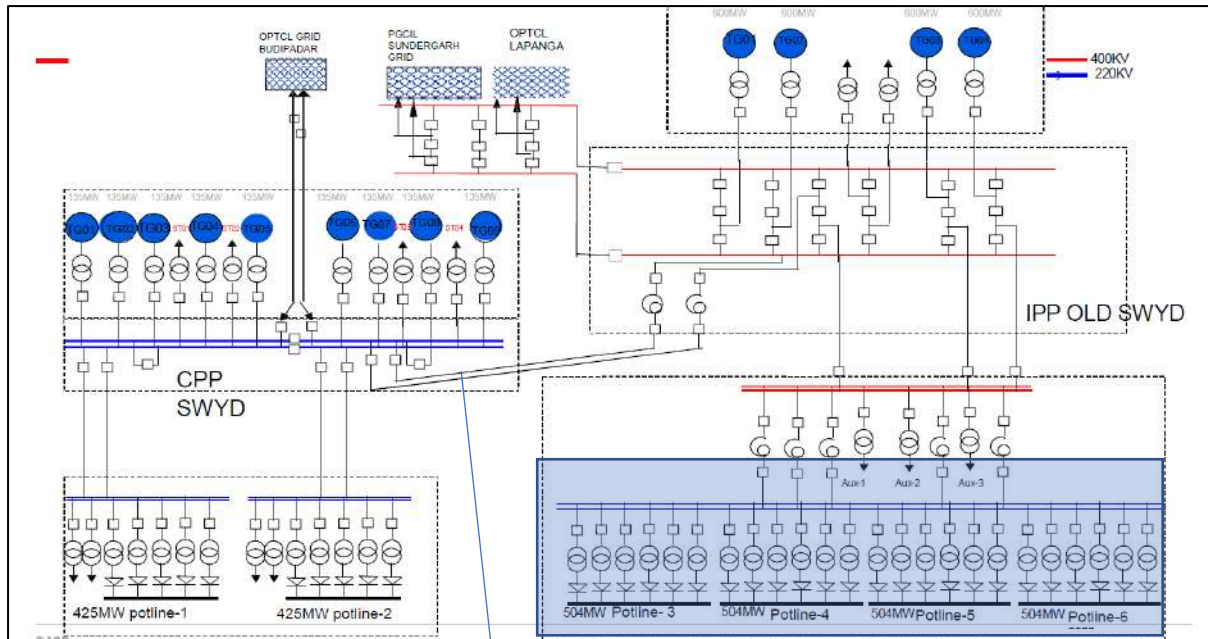

400 & 220 kv are decoupled with each other.

Smelter load at 400 Kv.

### Plant scenario prior to event:

- Unit 3 was out and Unit 1,2&4 was running with total generation of 1232 Mw.
- Sterlite was drawing 258 Mw from Grid ,so total load was 1490 MW.

At 17:48 Hrs due to fault in downstream within 400 kv Sterlite switchyard ,Smelter load reduced by 1450 Mw .

- As Sterlite load reduced ,Sterlite started exporting to the grid by 1182 Mw so total load reduced was 1450 Mw .
- At Sterlite SPS is there to take care of Huge injection in the grid which was set at 800Mw whenever injection is more than 800 MW it will limit it by generation reduction logic .
- Hence total generation to be reduced to limit till 800 Mw was ,1182-800= 382 Mw.

As per logic shown below priority 6 was satisfied

So generator 1 HP,LP Bypass occurred with generator 1 shedding which reduced the grid export within 800 Mw within 1 minutes .

| Accumulated generation shed table       | Priority | MW      |
|---|----------|---------|
| GEN2 HPLP                               | 1        | 81.417  |
| GEN2 HPLP+GEN1 HPLP                     | 2        | 225.621 |
| GEN2HPLP+GEN1 HPLP+GEN 4 HPLP           | 3        | 369.45  |
| GEN2HPLP+GEN1 HPLP+GEN 4 HPLP+GEN3 HPLP | 4        | 369.45  |
| GEN2                                    | 5        | 271.39  |
| GEN2+ GEN1 HPLP                         | 6        | 415.594 |
| GEN2+ GEN1 HPLP+GEN4 HPLP               | 7        | 559.423 |
| GEN2+ GEN1 HPLP+GEN4 HPLP+GEN 3 HPLP    | 8        | 559.423 |
| GEN2+GEN1                               | 9        | 752.07  |
| GEN2+GEN1+GEN4 HPLP                     | 10       | 895.899 |
| GEN2+GEN1+GEN4 HPLP+GEN3 HPLP           | 11       | 895.899 |
| GEN2+GEN1+GEN4                          | 12       | 1231.5  |
| GEN2+GEN1+GEN4+GEN3 HPLP                | 13       | 1231.5  |
| GEN2+GEN1+GEN4+GEN3                     | 14       | 1231.5  |

**ODISHA schedule vs Draw**

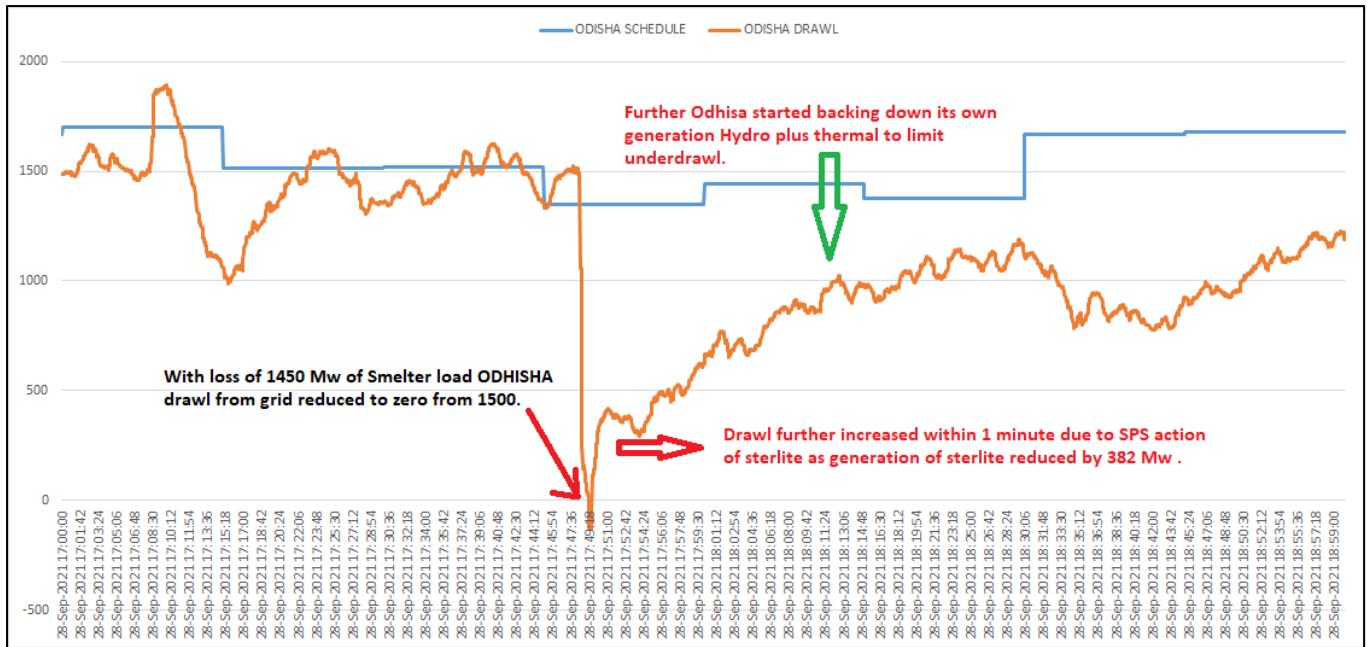

**Sterlite Draw from Grid:**

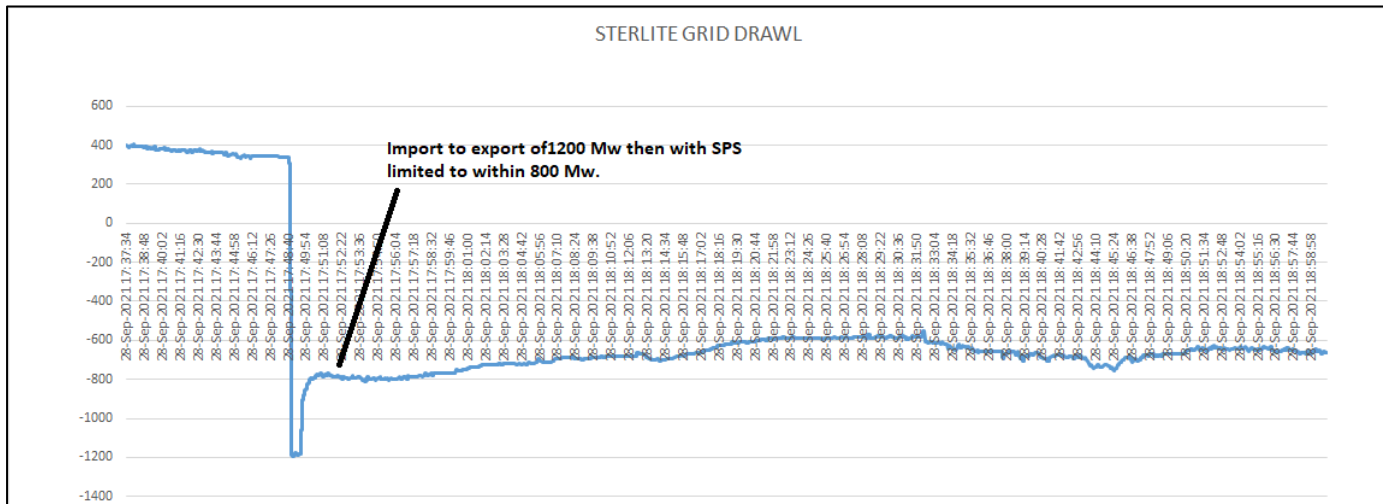



## Pictorial representation of connection arrangement

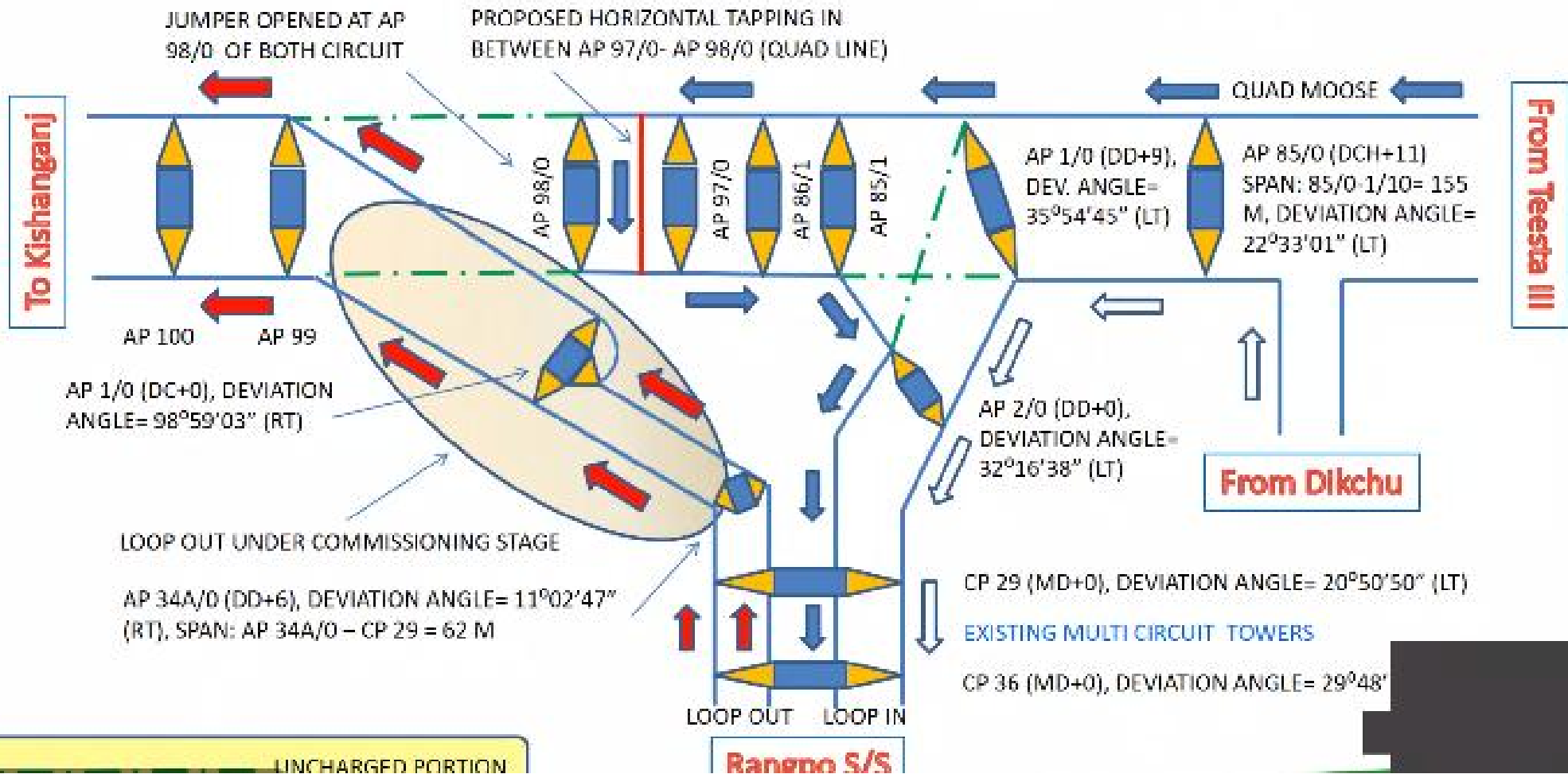

भारत सरकार  
केन्द्रीय विद्युत प्राधिकरण  
(विद्युत मंत्रालय)  
सेवा भवन (उत्तरी खंड) कक्ष सं. 622, छठा तल,  
आर.के.पुरम, नई दिल्ली-110066  
टेली. - 26103246, ई-मेल - [celegal-cea@gov.in](mailto:celegal-cea@gov.in)

वेबसाइट - [www.cea.nic.in](http://www.cea.nic.in)

## सार्वजनिक नोटिस

विद्युत अधिनियम, 2003 की धारा 177 के तहत प्रदत्त शक्तियों का प्रयोग करते हुए केंद्रीय विद्युत प्राधिकरण\* (के.वि.प्रा.) द्वारा (i) केन्द्रीय विद्युत प्राधिकरण (विद्युत संयंत्रों और विद्युत लाइनों के निर्माण के लिए तकनीकी मानक), विनियम 2010 को तारीख 07.09.2010 और 20.08.2010 (अंग्रेजी संस्करण) और (ii) केन्द्रीय विद्युत प्राधिकरण (विद्युत संयंत्रों और विद्युत लाइनों का निर्माण, प्रचालन और अनुरक्षण के लिए सुरक्षा आवश्यकताएं), विनियम 2011 को तारीख 24.01.2011 को अधिसूचित किये गये थे।

अब एक नए विनियम द्वारा "केन्द्रीय विद्युत प्राधिकरण (विद्युत संयंत्रों और विद्युत लाइनों के निर्माण के लिए तकनीकी मानक), विनियम 2010" को प्रतिस्थापित करने का प्रस्ताव है। तदनुसार, नए विनियम का प्रारूप नामतः "प्रारूप केंद्रीय विद्युत प्राधिकरण (विद्युत संयंत्रों और विद्युत लाइनों के निर्माण के लिए तकनीकी मानक) विनियम, 2021" को टिप्पणियों/सुझावों/आपत्तियों के लिए प्रकाशित किया जा रहा है।

इसके अतिरिक्त "केंद्रीय विद्युत प्राधिकरण (विद्युत संयंत्रों और विद्युत लाइनों का निर्माण, संचालन और रखरखाव के लिए सुरक्षा आवश्यकताएं) विनियम, 2011" के कुछ प्रावधानों में संशोधन करने का भी प्रस्ताव है। तदनुसार, नए विनियम का प्रारूप नामतः "प्रारूप केंद्रीय विद्युत प्राधिकरण (विद्युत संयंत्रों और विद्युत लाइनों का निर्माण, संचालन और रखरखाव के लिए सुरक्षा आवश्यकताएं) विनियम (संशोधन), 2021" भी टिप्पणियों / सुझावों / आपत्तियों के लिए प्रकाशित किया जा रहा है।

प्रस्तावित उपरोक्त दोनों नामतः विनियम के.वि.प्रा की वेबसाइट [www.cea.nic.in](http://www.cea.nic.in) पर उपलब्ध हैं। उक्त प्रारूप विनियमों को 14.02.2022 तक 11:00 बजे से 16:00 बजे तक किसी भी कार्य दिवस को मुख्य अभियंता (विधि), कमरा नं. 622, सेवा भवन (उत्तरी खंड), छठा तल, आर.के.पुरम, नई दिल्ली-110066 के कार्यालय में भी देखा जा सकता है।

सभी हितधारकों एवं जनता से अनुरोध है कि वे उक्त प्रारूप विनियमों पर अपनी टिप्पणी/सुझाव/आपत्तियां डाक अथवा ई-मेल ([celegal-cea@gov.in](mailto:celegal-cea@gov.in)) के माध्यम से मुख्य अभियंता (विधि), कमरा नं. 622, सेवा भवन, (उत्तरी खंड), 6वां तल, आर.के.पुरम, नई दिल्ली-110066 को 14.02.2022 तक भेजने का अनुरोध किया जाता है।

**(वी के मिश्रा)**  
**सचिव, के.वि.प्रा.**

\* केन्द्रीय विद्युत प्राधिकरण पूर्ववर्ती विद्युत (आपूर्ति) अधिनियम, 1948 के तहत गठित एक सांविधिक निकाय है, जिसे बाद में विद्युत अधिनियम, 2003 की धारा 70 द्वारा प्रतिस्थापित किया गया। के.वि.प्रा के प्रमुख कार्य हैं (i) बिजली क्षेत्र से संबंधित तकनीकी मामलों पर केंद्र/राज्य सरकारों, लाइसेंसधारियों, उत्पादन कंपनियों आदि को सलाह, (ii) उपभोक्ताओं के लिए विश्वसनीय, सस्ती बिजली प्रदान करने के लिए संसाधनों के इष्टतम उपयोग के लिए योजना एजेंसियों के बीच गतिविधियों का समन्वय,, (iii) संयंत्रों और बिजली लाइनों के निर्माण, संचालन और रखरखाव, ग्रिड मानकों, मीटरों की स्थापना, सुरक्षा आवश्यकता आदि से संबंधित नियम/तकनीकी मानक बनाना इत्यादि।

**GOVERNMENT OF INDIA**  
**CENTRAL ELECTRICITY AUTHORITY**  
**(MINISTRY OF POWER)**  
**Sewa Bhawan (North Wing), Room No. 622, 6<sup>th</sup> Floor,**  
**R. K. Puram, New Delhi-110066**  
**Tel. -011-26103246, email: celegal-cea@gov.in**  
**Website: www.cea.nic.in**

**PUBLIC NOTICE**

In exercise of the powers conferred under section 177 of the Electricity Act, 2003, the Central Electricity Authority (CEA)\* had notified (i) “Central Electricity Authority (Technical Standards for Construction of Electrical Plants and Electric Lines) Regulations, 2010” on 20.08.2010 & 07.09.2010 (Hindi version) and (ii) “Central Electricity Authority (Safety Requirements for Construction, Operation and Maintenance of Electrical Plants and Electric Lines) Regulations, 2011” on 24.01.2011.

It is now proposed to **replace** the “Central Electricity Authority (Technical Standards for Construction of Electrical Plants and Electric Lines) Regulations, 2010” by a new regulation. Accordingly, the draft new regulation *namely* “**draft Central Electricity Authority (Technical Standards for Construction of Electrical Plants and Electric Lines) Regulations, 2021**” are being published for comments/ suggestions/ objections.

It is also proposed to **amend** some provisions of “Central Electricity Authority (Safety Requirements for Construction, Operation and Maintenance of Electrical Plants and Electric Lines) Regulations, 2011”. Accordingly, the draft regulation *namely* “**draft Central Electricity Authority (Safety Requirements for Construction, Operation and Maintenance of Electrical Plants and Electric Lines) Regulations (Amendment), 2021**”, are also being published for comments/ suggestions/ objections.

The proposed aforementioned both draft regulations are available on the CEA Website [www.cea.nic.in](http://www.cea.nic.in). The said draft regulations can also be inspected in the office of Chief Engineer (Legal), Sewa Bhawan (North Wing), Room No. 622, 6th Floor, R. K. Puram, New Delhi 110066 on any working day till **14.02.2022** between 1100 hrs to 1600 hrs.

All the Stakeholders and members of public are requested to send their comments/ suggestions/ objections on aforementioned draft regulations to Chief Engineer (Legal), Sewa Bhawan (North Wing), Room No. 622, 6th Floor, R. K. Puram, New Delhi-110066 by post or through e-mail ([celegal-cea@gov.in](mailto:celegal-cea@gov.in)) latest by **14.02.2022**.

(V K Mishra)  
Secretary, CEA

\* CEA is a Statutory Body constituted under the erstwhile Electricity (Supply) Act, 1948, subsequently replaced by Section 70 of the Electricity Act, 2003. The major functions of CEA include (i) advices to the Union/State Governments, Licensees, Generating Companies etc. on the technical matters pertaining to power sector, (ii) coordination of activities amongst the planning agencies for optimal utilization of resources to provide reliable, affordable electricity for consumers, (iii) to make regulations/technical standards pertaining to construction, operation and maintenance of power of plants and electric lines, grid standards, installation of meters , safety requirement etc

[To be published in the Gazette of India, Extraordinary, in Part III, Section 4]

**Government of India  
Ministry of Power  
Central Electricity Authority**

New Delhi, , 2021

**NOTIFICATION**

**CEA/TETD/MP/R/01/2010**- In exercise of the powers conferred by sub-section (2) of Section 177 of the Electricity Act 2003, the Central Electricity Authority hereby makes the following regulations namely:

1. **Short Title and Commencement-**(1) These regulations may be called the Central Electricity Authority (Technical Standards for Construction of Electrical Plants and Electric Lines) Regulations, 2021 .  
  
(2) They shall come into force on the date of their publication in the Official Gazette.
2. **Definitions-** (1) In these regulations, unless the context otherwise requires,
  - (a) “act” means the Electricity Act, 2003;
  - (b) “authority” means the Central Electricity Authority established under sub-section (2) of Section 70 of the Act;
  - (c) “automatic voltage regulator” means a continuously acting automatic excitation control system to regulate a generating unit terminal Voltage;
  - (d) “autotransformer” means a power transformer in which at least two windings have common section;
  - (e) “base load operation” means operation at maximum continuous rating (MCR) or its high fraction;
  - (f) “basic insulation level (BIL)” means reference voltage level expressed in peak (crest) voltage with standard 1.2/50  $\mu$ s lightning impulse wave. Apparatus should be capable of withstanding test wave of basic insulation level or higher;

- (g) “black start” means the start up of a generating unit or gas turbine or internal combustion (IC) engine based generating set without use of external power following grid failure;
- (h) “boiler maximum continuous rating (BMCR)” means the maximum steam output, the steam generator (boiler) can deliver continuously at rated parameters;
- (i) “break time” means interval of time between the beginning of the opening of a switching device and the end of the arcing;
- (j) “cold start”, in relation to steam turbine, means start up after a shut down period exceeding 72 hours (turbine metal temperatures below approximately 40% of their full load values);
- (k) “combined cycle gas turbine (CCGT) module” means gas turbine generator(s), associated heat recovery steam generator (s) and steam turbine generator;
- (l) “control load”, in relation to coal or lignite based thermal generating units, means the lowest load at which the rated steam temperature can be maintained under auto control system;
- (m) “design head” means the net head at which peak efficiency of hydraulic turbine is attained while operating at rated output;
- (n) “generator transformer” means power transformer required to step up generator voltage to connected bus voltage;
- (o) “gross head” means the difference in elevation between the water levels of upstream reservoir and the center line of the turbine runner in case of Pelton turbine and tail race water level at the exit end of the draft tube in case of Francis and Kaplan turbine;
- (p) “gross heat rate”, in relation to gas turbine based and IC engine based thermal generating stations, means the external heat energy input required to generate one kWh (kilo Watt hour) of electrical energy at generator terminals;
- (q) “gross turbine cycle heat rate”, in relation to coal or lignite based thermal generating station, means the external heat energy input to the turbine cycle required to generate one kWh of electrical energy at generator terminals;
- (r) “high heat value (HHV)” means the heat produced by complete combustion of one kilogram of solid fuel or liquid fuel or one standard cubic metre ( $\text{Sm}^3$ ) of gaseous fuel as determined as per relevant Indian Standard (IS);

- (s) “highest system voltage” means the highest root mean square (r.m.s.) line to line value of voltage which can be sustained under normal operating conditions at any time and at any point in the system. It excludes temporary voltage variation due to fault conditions and the sudden disconnection of the large load;
- (t) “hot start”, in relation to steam turbine, means start up after a shut down period of less than 10 hours (turbine metal temperatures approximately 80% of their full load values);
- (u) “house load” means the unit is operating in isolation to the grid and generating electric power to cater to its own auxiliaries;
- (v) “impedance earthed neutral system” means a system whose neutral point(s) is(are) earthed through impedances to limit earth fault currents;
- (w) “impulse” means a unidirectional wave of voltage or current which, without appreciable oscillations, rises rapidly to a maximum value and falls, usually less rapidly, to zero with small, if any, loops of opposite polarity. The parameters which define a voltage or current impulse are polarity, peak value, front time, and time to half value on the tail;
- (x) “impulse withstand voltage” means peak value of the standard impulse voltage wave which the insulation of an equipment is designed to withstand under specified test conditions;
- (y) “insulation co-ordination” means the selection of the dielectric strength of equipment in relation to the voltages which can appear on the system for which the equipment is intended and taking into account the characteristics of the available protective devices;
- (z) “isolated neutral system” means a system where the neutral point is not intentionally connected to earth, except for high impedance connections for protection or measurement purposes;
- (za) “maximum continuous rating (MCR)”, -
  - (i) in relation to coal or lignite based thermal generating units, means maximum continuous output at the generator terminals (net of any external excitation power) as guaranteed by the manufacturer at the rated parameters;
  - (ii) in relation to combined cycle gas turbine module, means the sum of maximum continuous output of the Gas Turbine Generator(s) and Steam Turbine Generator measured at the generator terminals (net of any external excitation power) as guaranteed by the manufacturer for design fuel and corresponding to site conditions;



- (iii) in relation to IC engine based generating sets, means maximum continuous output at the generator terminals (net of any external excitation power) as guaranteed by the manufacturer for design fuel and corresponding to site conditions;
- (zb) “maximum net head” means the net head resulting from the difference in elevations between the maximum head water level and the center line of turbine runner for vertical Pelton turbine and tailrace water level for vertical Francis turbine with one unit operating at no load speed corresponding to turbine discharge of approximately 5% of the rated flow. Under this condition, the hydraulic losses are negligible and may be disregarded;
- (zc) “mesh voltage” means the maximum touch voltage within a mesh of a ground grid;
- (zd) “minimum net head” means the net head resulting from the difference in elevation between the minimum head water level or the minimum draw down level and the center line of turbine runner for vertical Pelton turbine and the maximum tail water level for vertical reaction turbine;
- (ze) “minimum tail water level” for a hydro station means the water level in the discharge chamber in case of Pelton turbine and tail race at the exit end of the draft tube in case of Francis and Kaplan turbines corresponding to a discharge required to run one machine at no load;
- (zf) “motor control centre“ means the switchgear which contains modules for electric supply to motor and associated load like heaters, actuators, control transformers etc. and their control;
- (zg) “net head” means the gross head less all hydraulic losses, including draft tube exit losses, wherever applicable and excluding those pertaining to the turbine;
- (zh) “overhead line” means any electric line which is placed above the ground and in the open air, but does not include live rails of traction system;
- (zi) “owner” means the company or body corporate or association or body of individuals, whether incorporated or not or artificial juridical person who owns or operates or maintains Electrical Plants and/or Electric Lines;
- (zj) “power system stabilizer” means controlling equipment which receives input signals of speed, frequency and power to control the excitation via the voltage regulator for damping power oscillations of a synchronous machine;

- (zk) “performance coal” means the coal of quality for which steam-generator performance is guaranteed by the manufacturer;
- (zl) “power transformer” means a transformer that transfers electric energy in any part of the circuit between the generator and the distribution primary circuits;
- (zm) “pump turbine” means a hydraulic turbine having a runner capable of running in one direction in generating mode and reverse direction in pumping mode;
- (zn) “pumped storage plant” means a system of generating electricity in which the electricity is generated during the peak hours by using water that has been pumped into upper reservoir during off-peak hours from the lower reservoir;
- (zo) “runaway speed” means the speed attained by the hydraulic turbine at full gate opening while operating at maximum head conditions when the generator is disconnected from the system and the governor is in-operative;
- (zp) “solidly earthed neutral system” means a system whose neutral point(s) is (are) earthed directly;
- (zq) “specific speed” defined in m. kW, in relation to hydraulic turbine, means the speed in rpm at which a given hydraulic turbine would rotate, if reduced homologically in size, so that it would develop 1 kW under 1 meter of net head;
- (zr) “station” means either the Thermal Generating Station or Hydro-electric Generating Station depending upon the context;
- (zs) “station transformer” means power transformer required to step down the grid voltage to cater to the starting and shut down of generating unit load and station load during running;
- (zt) “step potential” means the maximum value of potential difference possible of being shunted by a human body between accessible points on the ground separated by distance of one pace which may be assumed to be one metre;
- (zu) “sub-critical unit”, in relation to coal or lignite based thermal generating unit, means a unit designed for main steam pressure less than the critical pressure (225.56 kg/ cm<sup>2</sup>);
- (zv) “super-critical unit”, in relation to coal or lignite based thermal generating unit, means a unit designed for main steam pressure more than the critical pressure (225.56 kg/cm<sup>2</sup>);

- (zw) “surge arrester” means a protective device for limiting surge voltages on equipment by diverting surge current and returning the device to its original status and is able to repeat these functions as specified;
- (zx) “switchyard” means a sub-station associated with a generating station for transforming electricity for further transmission;
- (zy) “synchronous condenser mode” refers to that condition of the synchronous machine coupled to the turbine when it is running only with mechanical load and supplying leading or lagging reactive power;
- (zz) “thermal generating station” means the ‘generating station’ as defined in the Act for generating electricity using fossil fuels such as coal, lignite, gas, liquid fuel or combination of these as its primary source of energy;
- (zza) “touch potential” means the potential difference between the object touched and the ground point just below the person touching the object when ground currents are flowing;
- (zzb) “transformer” means a static electric device consisting of a winding, or two or more coupled windings, with or without a magnetic core, for introducing mutual coupling between electric circuits to transfer power by electromagnetic induction between circuits at the same frequency, usually with changed values of voltage and current;
- (zzc) “transients” means over voltage or over current phenomena prevailing in an electrical system for a short period of the order of a fraction of a second or a few seconds not exceeding five seconds;
- (zzd) “turbine setting”, in relation to hydro-electric generating station, means the elevation of runner center line with respect to maximum tail water level for vertical Pelton turbine installation and the elevation with respect to minimum tail water level for Francis/ Kaplan turbine installation;
- (zze) “unit auxiliary transformer” means the transformer meant for catering the loads connected to unit buses corresponding to auxiliaries required for respective Boiler, Turbine and Generator;
- (zzf) “unit”,-
  - (i) in relation to a coal or lignite based thermal generating station, means steam generator with interconnected steam turbine-generator and auxiliaries, operated as one single set or system to generate electric power;

- (ii) in relation to a hydro- electric generating station, means generator with interconnected turbine and auxiliaries, operated as one single set or system to generate electric power.
- (zzg) “ultra super-critical unit” in relation to coal or lignite based thermal generating unit means a supercritical unit with steam temperature of 600/600<sup>0</sup>C or higher at turbine inlet;
- (zzh) “warm start”, in relation to steam turbine, means start up after a shut down period between 10 hours and 72 hours (turbine metal temperatures between approximately 40% and 80% of their full load values).
- (2) words and expressions used but not defined above shall have the same meaning respectively assigned to them in the Act.
- (3) Applicability. - These regulations shall apply to generating companies, transmission licensees, distribution licensees, Central Transmission Utility, State Transmission Utilities.

## CHAPTER I

### GENERAL REQUIREMENTS

- 3. **General Requirements-** (1) The Electrical Plants and Electric Lines shall be suitable for full range of ambient and other environmental conditions as prevailing at site.
  - (2) The various parts or components or assemblies of equipment and systems shall be of proven materials with well established physical and chemical properties appropriate to the service as intended.
  - (3) All equipment and systems installed shall comply with the provisions of statutes, regulations and safety codes, as applicable.
  - (4) The Electrical Plants and Electric Lines shall be designed to comply with requirements stipulated in other CEA Regulations as well, framed under Electricity Act 2003.
  - (5) (a) The design, construction and testing of all equipment, facilities, components and systems shall be in accordance with latest version of relevant standards and codes issued by Bureau of Indian Standards (BIS) and/or reputed international standards viz. IEC Standard/ ASME/ DIN or equivalent and codes. However, in the event of any conflict between the requirements of the international standards or codes and the requirements of the BIS (Bureau of Indian standards) standards or codes, the latter shall prevail.

(b) For standardization of Test Protocols in Power Sector, "CEA Guidelines for the validity period of Type Test Certificate for Major Electro-Mechanical Equipment in Power Sector" shall be followed.

(6) All materials, components and equipment shall be tested at all stages of procurement, manufacturing, erection, commissioning as per comprehensive Quality Assurance Programme to be agreed mutually between the Owner and the equipment supplier and which shall comply to the "CEA Guidelines on Model Quality Assurance Programme (QAP) for Major Electro-Mechanical Equipment in Power Sector".

(7) The SI (International System) or MKS (metre, kilogram and second) system of units shall be used for design, drawings, diagrams, instruments etc.

(8) The owner shall retain at the site following documents:

(a) As-built drawings including, but not limited to the civil and architectural works;

(b) Copies of the project design memorandum, technical description, data sheets, operating manuals and manufacturer's warranties for all major items and/ or equipment;

(c) Copies of the results of all tests performed as per contract and;

(d) Technical documents relating to the design, engineering and construction of the electrical plant and/or electric line.

(9) (a) The Owner shall implement information technology based system for effective project monitoring so as to facilitate timely execution of the projects of capacity equal to or higher than capacity indicated below :

(i) Thermal generating station : 250 MW;

(ii) Hydro generating station : 100 MW;

(iii) Transmission lines and sub-stations : 220 kV and above.

(b) The system shall monitor status of ordering, engineering, supplies and physical progress of site activities and help in identifying the bottlenecks in achieving the scheduled completion of the project. The system shall be web based and shall have connectivity with major suppliers/contractors and shall also have provision for connection to centralized project monitoring system of the Authority.

## CHAPTER II

### TECHNICAL STANDARDS FOR CONSTRUCTION OF THERMAL GENERATING STATIONS

4. Technical Standards for construction of Thermal Generating Stations are covered in following four parts:

- Part- A: Common to all types of Thermal Generating Stations;
- Part- B: Coal or lignite based Thermal Generating Stations;
- Part- C: Gas Turbine based Thermal Generating Stations;
- Part- D: Internal Combustion (IC) Engine based Thermal Generating Stations.

#### PART- A

##### COMMON TO ALL TYPES OF THERMAL GENERATING STATIONS

5. **General Technical Requirements-** (1) The coal, lignite and gas based thermal generating stations shall be designed to give life of not less than twenty five (25) years. IC engine based Stations shall be designed for life not less than fifteen (15) years.

(2) The Station shall comply with all applicable environmental stipulations of Ministry of Environment, Forests and Climate Change (MoEF&CC) in regard to ambient air quality, gaseous emissions, liquid effluent discharges, solid waste disposal, Noise level and any other stipulation of the Central Pollution Control Board (CPCB) and State Pollution Control Board (SPCB) in this regard.

(3) **Noise level**

- (a) Noise level at the Station boundary shall not exceed the ambient air quality standard in respect of noise as notified by Ministry of Environment, Forest and Climate Change (MoEF&CC) and any other stipulation of the Central Pollution Control Board (CPCB) and State Pollution Control Board (SPCB) in this regard.
- (b) Noise level for the continuously operating equipment shall not be more than 85 dBA at a distance of 1 metre and at a height of 1.5 metre from any equipment except for the following:
- i) Turbine- Generator and Pulverizers - 90 dBA

- ii) Safety valves and associated vent pipes, HP/LP Bypass Valve, Soot blowers/ Wall blowers, Regulating drain valves – 115 dBA
- iii) IC engine based generating sets of capacity upto 1 MVA. They shall meet the stipulations of Ministry of Environment, Forest and Climate Change (MoEF&CC) on “Noise limit for generator sets run with diesel”. For other than 1MVA capacity, it shall be provided with acoustic enclosure or by treating the room acoustically in line with MoEF&CC stipulations.

Provided that for short term exposure, noise levels shall not exceed the limits as stipulated in the Occupational Safety & Health Administration (OSHA) Standard.

- (c) Equipment/ machines shall be provided with acoustic enclosure or acoustic treated building, wherever required so as not to exceed the permissible noise limits.
- (4) Areas where a potential flammable atmosphere exist shall be classified in accordance with the provisions of latest version of relevant IS.

Provided that to the extent practicable, equipment requiring operator’s attention and electrical equipment shall not be installed in hazardous areas.

- (5) All the equipment and surfaces (excluding coal or lignite mills, pulverized fuel pipes, lube oil piping and electrical equipment) having skin temperature more than 60°C shall be provided with required insulation along with cladding.

Provided that the insulating materials, accessories and protective covering shall be non- sulphurous, incombustible, low chloride content, chemically rot proof, non-hygroscopic and shall withstand continuously and without deterioration the maximum temperature to which they can be subjected as per duty conditions.

Provided further that the insulation or finishing materials containing asbestos in any form shall not be used.

- (6) Auxiliaries involving large power consumption such as motor driven boiler feed pumps (BFPs), induced draft (ID) fans (radial type) shall be provided with variable frequency drive (VFD) or hydraulic coupling to optimize power consumption.

## **6. Site Selection and Layout Considerations**

- (1) **Site selection-** The following criteria shall be considered for selection of site for thermal generating stations:
  - (a) Availability of adequate land for the Station;



- (b) Avoidance of proximity to geological faults, high flood zone of rivers or the high tide zones of sea/ backwaters;
  - (c) Siting criteria prescribed by MoEF&CC;
  - (d) Availability of required water;
  - (e) Feasibility of rail, road or other linkages for transportation of fuel and equipment to the site;
  - (f) Feasibility of power evacuation.
- (2) **Layout considerations-** The following minimum layout requirements shall be complied with as may be applicable for coal or lignite or gas turbine based Stations:
- (a) The layout of the Station shall be compact so as to optimise use of land, materials and minimize system losses.
  - (b) Adequate provision shall be made in regard to space and access in order to carry out the maintenance of various equipment.
  - (c) Adequate maintenance facilities shall be provided, as required, for assembly, disassembly and handling during maintenance of various equipment.
  - (d) Due consideration shall be given for the wind direction while deciding on the relative location of the following:
    - (i) Cooling tower and switchyard to minimize the moisture drift towards the switchyard;
    - (ii) Chimney and ash disposal area with respect to township and adjoining habitation areas (applicable for coal or lignite based generating stations).
  - (e) (i) Adequate space shall be provided for unloading and maintenance purposes in Turbine- Generator (TG) area.
    - (ii) Requisite lay down area shall be provided for each unit on TG floor and same shall be approachable with electric overhead travelling (EOT) crane.
    - (iii) In case of coal or lignite based generating stations, two transverse bays shall be provided in TG area at ground level for unloading and maintenance purposes and for Stations with multiple units, adequate space shall be provided to meet the requirement for simultaneous maintenance of two units.

- (f) Coal or lignite mill-bunker bay shall preferably be located either on sides or rear of the steam generator to avoid the dust nuisance and in case bunker bay is located adjacent to TG area, suitable isolation arrangement shall be provided to avoid entry of coal or lignite dust in TG area.
- (g) Adequate fire escape staircases shall be provided in TG building with fire doors at each landing.
- (h) For coal or lignite based generating stations, interconnecting walkways between TG building and steam generator shall be provided at TG operating floor level and at deaerator floor level.

Provided that walkways at various levels shall also be provided for interconnection between steam generator and mill-bunker bay.

- (i) Minimum one staircase, for each unit or module, and minimum one elevator shall be provided in the TG building and in addition, at least the following elevators shall also be provided for coal or lignite based generating stations:
  - (i) One passenger-cum goods elevator for each steam-generator;
  - (ii) One elevator for chimney with suitable landings.
- (j) Adequate number of permanent stores and open paved yard shall be provided as per requirement of the Station for storage of spares and materials etc.

## **PART- B**

### **COAL OR LIGNITE BASED THERMAL GENERATING STATIONS**

- 7. Operating Capabilities of a Unit in the Station-** (1) The unit shall give MCR output under the following conditions:

- (a) Maximum cooling water temperature at site;
- (b) Worst fuel quality stipulated for the unit;
- (c) Operating frequency variation of -5% to +3% (47.5 Hz to 51.5 Hz).

- (2) The unit shall be capable of base load operation.

Provided that the unit shall also be capable of regular load cycling and two-shift operation.

- (3) The steam turbine shall be designed for a minimum of 4000 hot starts, 1000 warm starts and 150 cold starts during its life.

- (4) (a) The sub-critical unit shall be designed for constant pressure and sliding pressure operation.
- (b) The supercritical unit shall be designed for sliding pressure operation/ modified sliding pressure condition.
- (c) At any operating load, the throttle reserve shall be sufficient so as to achieve an instantaneous increase in turbine output by 5% of the corresponding load with maximum output limited to 105%.
- (5) The design shall cover adequate provision for quick start up and loading of the unit to full load at a fast rate.  
Provided that the unit shall have minimum rate of loading or unloading of 3% per minute above the control load (i.e. 50% MCR).
- (6) The unit shall be capable of automatically coming down to house load and operation at this load in the event of sudden external load throw off.

**8. Steam Generator (Boiler) and Auxiliaries-** (1)The steam generator shall normally be based on pulverized fuel combustion and shall be of sub-critical or super- critical type with single pass or two pass or any other proven flue gas path configuration.

Provided that wherever very low grade fuel or coal or lignite with high sulphur content is stipulated, fluidized bed combustion (FBC) based steam generator may also be considered based on Owner’s assessment of techno-economics and availability of proposed unit size.

(2) The efficiency of the steam-generator (on high heat value basis) in %, as guaranteed by the manufacturer, shall not be less than the value as arrived with the following formula for the quality of performance coal or lignite:

$$\text{Minimum steam generator efficiency (\%)} = 92.5 - \frac{[ 50xA + 630(M+9xH) ]}{\text{HHV}}$$

where,

- A = % ash in fuel;
- M = % moisture in fuel;
- H = % hydrogen in fuel and;
- HHV = high heat value of fuel in kcal/kg.

(3) The steam generator and its auxiliaries shall be suitable for outdoor installation.

(4) Boiler maximum continuous rating (BMCR) shall correspond to at least 102% of the steam flow at turbine inlet under VWO (valves wide open) condition [including overload valves (HP stage by pass), if provided] plus

continuous steam requirement for auxiliary systems of the unit (e.g. fuel oil heating, etc.) when unit is operating above control load and the steam generator shall be capable to give BMCR output for the worst fuel quality stipulated.

(5) All parts of the steam generator including pressure parts, vessels, piping, valves including safety valves and fittings shall meet the requirements of Indian Boiler Regulations (IBR).

(6) All start up vents shall be provided with two valves in series - one motorized isolating and other motorized regulating type.

(7) If indigenous coal is proposed as main fuel, its typical characteristics (high abrasive ash, slow burning, high ash resistivity, etc.) shall be given due consideration while designing the steam generator and auxiliaries.

(8) Pressure withstand capability of the furnace shall correspond to minimum +/- 660 mmwc at 67% yield strength or maximum expected pressure/draft of fans, whichever is higher.

(9) Maximum average gas velocity, when using indigenous coal, in any zone of furnace, superheater, reheater, economizer shall be 10 m/sec to prevent erosion of pressure parts and maximum local velocity can be upto 12 m/s.

(10) For pulverized coal or lignite based steam-generators, fuel oil firing system shall be provided for start-up and low load flame stabilization and Light diesel oil (LDO) and/or heavy fuel oil shall be used for fuel oil firing system.

(11) Pulverised fuel combustion based steam generator shall not require oil support above 40% BMCR load.

Provided that FBC based steam-generator shall be designed such that oil support is not needed beyond 25% BMCR load.

(12) The pulverized fuel system shall meet the following requirements:

(a) Design of pulverized fuel system shall comply with requirements of National Fire Protection Association (NFPA);

(b) Coal or lignite preparation system for pulverized fuel system shall have sufficient spare milling capacity (e.g. at least one spare mill when using worst coal corresponding to MCR in case of medium speed mills);

(c) Coal supply to the mills shall be from the individual coal bunkers having storage capacity of about 10 hours for the unit operation at MCR;

(d) The coal fineness achieved from the pulverisers shall be at least 70% thru 200 mesh (75 microns) and 98% thru 50 mesh (300 microns) at rated capacity of the pulveriser, with an input coal size up to 50 mm.

(13) To maintain balance draft conditions in the furnace over the entire load range while burning the stipulated range of fuel, 2x60% forced draft (FD) fans and 2x60% induced draft (ID) fans shall be provided.

(14) Suitable air pre-heating system shall be provided for recovery of useful heat from the exhaust flue gases.

Provided that steam coil air pre-heater(SCAPH) may also be provided for maintaining air temperature within safe limits to prevent acid corrosion during start up or very low ambient air temperature conditions.

(15) The soot blowing system shall be provided for the waterwall, superheater, reheater, economizer and air preheater.

(16) The dust collecting system (electro-static precipitator, bag filter etc.) shall be provided for removing suspended particulate matter (SPM) from the flue gases to meet the statutory stipulation as per environmental clearances and electro-static precipitator (ESP) shall comply with following requirements:

(a) ESP shall be able to meet the stipulated SPM emission requirement even when one electric field in each pass of the ESP is out of service while firing stipulated worst fuel with unit operation at MCR;

(b) ESP shall be provided with effective ash evacuation system having controls for ash temperature and monitoring of ash level in the hopper.

(c) Each hopper shall have a storage capacity of minimum of eight (8) hours with unit operation at MCR and the hopper valley angle to the horizontal shall be minimum 60 degrees;

(d) Specific weight of ash may be considered not more than 650 kg/m<sup>3</sup> for determining hopper storage capacity and not less than 1350 kg/m<sup>3</sup> for ESP structural design;

(e) Pressure withstand capability of the ESP casing shall correspond to minimum +/- 660 mmwc at 67% yield strength and flue gas temperature of 200°C.

**9. Steam Turbine and Auxiliaries-(1)** The steam turbine shall comply with latest versions of relevant International Electro-technical Commission (IEC) standards or equivalent.

(2) The gross turbine cycle heat rate as guaranteed by the equipment manufacturer shall not exceed the following values:

**Table 1**

| <b>Unit rating (MW)</b>      | <b>Heat rate* (kcal/kWh) at 100% MCR with motor driven BFP</b> | <b>Heat rate* (kcal/kWh) at 100% MCR with turbine driven BFP</b> |
|------------------------------|--|--|
| 50 MW to less than 100 MW**  | 2280   | -  |
| 100 MW to less than 200 MW** | 2000   | -  |
| 200 MW to less than 250 MW** | 1970   | -  |
| 250 MW to less than 500 MW** | 1955   | -  |
| 500 MW and above**           | 1895   | 1935   |
| Supercritical units          | 1770   | 1830   |
| Ultra Supercritical units    | 1725   | 1790   |

\*corresponding to reference conditions of 33°C cooling water temperature and 0% de-mineralised water make up.

\*\* sub-critical units.

(3) The steam turbine shall be of tandem or cross compound construction, reheat, condensing type with number of uncontrolled extractions as optimized for regenerative feed heating.

(4) The steam flow through steam turbine under valves wide open (VWO) condition shall correspond to 105% of steam flow corresponding to MCR output and the turbine output under VWO condition shall be minimum 105% of MCR output.

(5) A self-contained lubricating oil system shall be provided for each steam turbine-generator.

Provided that one main oil pump (MOP) shall be provided which may be either directly driven by turbine shaft or by an AC motor with a minimum of one AC motor driven auxiliary oil pump as standby for the main oil pump.

Provided further that provision shall also be made for one DC motor driven emergency oil pump for meeting lubricating oil requirement during non-availability of AC motor driven pump.

(6) Suitable mechanism shall be provided to ensure lubrication and prevent damage to bearings of steam turbine-generator during starting or turning gear operation.

Provided that in case jacking oil system is provided to supply high pressure oil to bearings of steam turbine-generator to lift the rotor during starting or turning gear operation, the same shall be with 2x100% jacking oil pumps (one AC driven and one DC driven).

Provided further that hand barring gear shall be provided for manually rotating the turbine in an emergency.

(7) The oil used for turbine governing (control) shall be supplied either from the lubricating oil system or from a separate control oil system and in case of separate control oil system, the pumps provided shall be of 2x100% capacity.

Provided that fire resistant fluid shall be used in control fluid system for all hydraulically operated valves/ servo motor of turbine stop and control valves.

(8) Each steam turbine shall be provided with one main oil tank of capacity 5 to 8 oil changes per hour (at normal operating level) and oil purification system of adequate capacity and in addition, the station shall be provided with central turbine oil storage and purification system consisting of one pure oil tank, one dirty oil tank and oil purification unit.

(9) The steam turbine shall be provided with electronically controlled electro-hydraulic governing system.

Provided that the steam turbines of rating higher than 200 MW shall be provided with back up governing system of mechanical hydraulic or electro-hydraulic type.

(10) The turbine shall be provided with protective devices as per relevant IEC or equivalent, including the following:

- (a) Separately actuated over-speed trip device;
- (b) Emergency hand trip devices to facilitate manual tripping of the turbine locally and from control room.

(11) Turbine vibrations shall be minimized and shall be within limits as per latest version of relevant standards of International Organisation for Standardisation (ISO).

(12) Non-return valves shall be provided in the steam extraction lines as required for protection from overspeed that may result from sudden load throw off or turbine trip.



(13) Hydraulic or pneumatic or DC operated device shall be provided for rapid reduction of vacuum in condenser to bring turbine rotor to rest as quickly as possible under emergency conditions.

(14) The start-up and drainage system shall comply with relevant American National Standards Institute (ANSI) or American Society of Mechanical Engineers (ASME) Standard or equivalent regarding prevention of water damage to steam turbines.

(15) For steam turbines of rating higher than 100 MW, turbine by-pass system of capacity not less than 60% of BMCR steam flow shall be provided for fast hot & warm start ups of unit, dumping steam in condenser during sudden turbine trip (without tripping the steam generator), unit house load operation etc.

(16) Condensate polishing system shall be provided in the steam turbine cycle for the following:

- (a) units with rated pressure of about 170 kg/cm<sup>2</sup> and above at turbine inlet;
- (b) units with once- through steam generators;
- (c) units using sea water for condenser cooling.

(17) Suitable feed water regenerative system consisting of low pressure heaters, deaerator and high pressure heaters shall be provided for optimized cycle efficiency.

Provided that feed water heaters and deaerator shall be designed in accordance with the ASME boiler & pressure vessels codes and ~~HEI~~ (Heat Exchanger Institute (HEI) Standards or equivalent.

(18) Steam condenser shall meet the following requirements:

- (a) The design, manufacturing and testing of condenser shall be as per HEI Standards or equivalent;
- (b) Condenser tubes shall be of stainless steel except in case of units using sea water for cooling in which case condenser tubes shall be of titanium;
- (c) On load condenser tube cleaning system shall be provided for regular cleaning of condenser tubes.  
Provided that debris filter shall also be provided at condenser inlet for sea water application;
- (d) Vacuum pumps or steam ejectors shall be provided as per HEI Standards or equivalent for evacuating air steam mixture and non-condensable gases from the condenser.

(19) 3x50% or 2x100% condensate extraction pumps as per Hydraulic Institute Standards (HIS) design shall be provided for each unit.

(20) The unit shall be provided with boiler feed pumps of adequate capacity to give rated output and the design shall meet the requirements of HIS or equivalent.

Provided that the following configurations may be adopted subject to compliance of IBR:

(a) *Large Size Units (500 MW & above)*

2x50% or 1x100% turbine driven Boiler Feed Pump (BFP) ~~(s)~~ plus one (1) number motor driven BFP of adequate capacity for start-up of the unit.

or

2X50% motor driven BFPs.

(b) *Small Size Units (<500MW)*

3x50% or 2x100% motor driven BFPs.

## **10. Electrical System**

(1) **General requirements**

(a) For the purpose of design of electrical equipment and systems, an ambient temperature of 50°C and relative humidity of 95% shall be considered and the equipment shall be suitable for operation in a highly polluted environment.

Provided that for equipment installed in air conditioned areas, design ambient temperature shall be 35° C.

(b) The telecommunication system shall be based on optical fibre or power line carrier communication (PLCC) or both.

Provided that Owner's telecommunication equipment provided to transmit the required data of the Station to the procurer of electricity, Regional or State Load Despatch Centre and Transmission Company shall have matching equipment and compatible communication protocol with the receiving end.

(2) **Generator**

(a) The generator shall comply with relevant IS or IEC standard.

- (b) The efficiency of generator shall be more than 98% at rated load.
- (c) Insulation shall be thermal class-F for stator and rotor winding as per relevant IEC with temperature rise limited corresponding to thermal class-B insulation.
- (d) Generator shall be either hydrogen cooled or hydrogen & water cooled or air cooled type.

Provided that the hydrogen cooled generator shall be capable of delivering at least two third of its rated output with one hydrogen gas cooler out of service.

- (e) Resistance temperature detectors (RTDs) or thermocouples shall be provided at suitable locations for monitoring the temperatures of stator core, stator windings and bearings.

Provided that suitable arrangements shall also be made for monitoring the temperature of the rotor winding in case static excitation system is provided.

- (f) For hydrogen cooled generators, hydrogen gas system shall be provided with driers (if applicable) of 2x100% duty to maintain dryness of hydrogen inside the machine.

Provided that suitable system shall be provided to prevent condensation during long shut down.

Provided further that the system shall have the provision of on-line dew point measurement as well as gas analyser.

- (g) For water cooled stator winding, stator water cooling system shall be closed loop type with 2x100% AC motor driven circulating water pumps, 2x100% de-mineralised (DM) water heat exchangers, 2x100% filters, one mixed bed de-mineraliser and one alkalizer unit (as applicable).

- (h) In case of hydrogen cooled machines, the seal oil system provided shall be equipped with 2x100% AC motor driven pumps and 1x 100% DC motor driven pump and the system shall be provided with coolers and filters having 2x100% duty.

Provided that any other proven system as per OEM practice or recommendations shall also be acceptable subject to acceptance of the owner.

- (i) *Excitation System*

- (i) Suitable generator excitation system as well as automatic voltage regulator (AVR) shall be provided with the generator as per

Central Electricity Authority (Technical Standards for Connectivity to the Grid) Regulations, 2007, as amended from time to time.

Provided that power system stabilizer (PSS) shall be provided in AVR for generator of 100MW and higher rating.

(ii) The rated current of the excitation system shall be at least 110% of the machine excitation current at the rated output of the machine and the rated voltage shall be at least 110% of the machine excitation voltage.

(iii) (a) Automatic voltage regulator shall have 2x100% auto channels and automatic changeover.  
Provided that in the event of failure of auto channels, manual control shall be possible.

(b) In case of static excitation system, power thyristor converter shall be fully controlled three phase, full wave bridge type with fast and high ceiling performance. The converter shall have 'N+2' redundancy where N is the number of bridges required to deliver rated excitation current and 'N+1' number of bridges shall deliver the ceiling voltage/current.

(c) In case of brushless excitation system, rectifier assembly shall be provided with either complete bridge as redundant or at least one redundant parallel branch in each of the six arms of the bridge.

(j) *Instrument Transformers*

(i) *Current transformers*

The type and accuracy of current transformers for protection purposes shall comply with relevant IS/ IEC Standards.

Provided that current transformers for metering shall also comply with Central Electricity Authority (Installation and Operation of Meters) Regulations, 2006.

(ii) *Voltage transformers*

The type and accuracy of Voltage transformers for protection purposes shall comply with relevant IS/ IEC Standards.

Provided that voltage transformers for metering shall also comply with Central Electricity Authority (Installation and Operation of Meters) Regulations, 2006.

(3) **Power transformers**

- (a) The power transformers (generator transformer, unit auxiliary transformers, station transformers) shall comply with latest versions of relevant IS/ IEC Standards.
- (b) The generator transformer shall be- (i) provided to step up generating voltage for connection to the grid.

Provided that it shall also be used to provide start-up power from the grid in case circuit breaker is provided between the generator and generator-transformer in generator circuit breaker (GCB) scheme.

(ii) filled with mineral oil and cooling shall be of oil forced air forced (OFAF) or oil directed air forced (ODAF) type.

Provided that alternate cooling arrangement viz. oil natural air forced (ONAF), or oil natural air natural (ONAN) may also be adopted depending upon unit size.

(iii) provided with two or more cooling radiator banks with suitable number of standby fans and oil pumps

Provided that the total capacity of coolers for each transformer shall be minimum 120% of actual requirements.

- (c) The unit auxiliary transformer(s) (UAT) shall be- (i) used to meet the unit load requirement during normal running of the unit.

Provided that in case of GCB scheme, it shall provide power requirement of the unit auxiliaries and station auxiliaries during start-up and normal running of the unit.

(ii) filled with mineral oil and cooling shall be of oil natural air forced (ONAF) or oil natural air natural (ONAN) type.

Provided that oil forced air forced (OFAF) or oil directed air forced (ODAF) cooling are also acceptable depending upon transformer size.

(iii) provided with two or more cooling radiator banks with suitable number of standby fans and oil pumps'

Provided that the total capacity of coolers for each transformer shall be minimum 120% of actual requirements.

- (d) The station transformer(s) shall be- (i) used to cater the start-up power requirement, station auxiliary load requirement during normal operation of the unit(s) and unit load in case of outage of UAT.

Provided that in case of GCB scheme, station transformer may not be required.

(ii) filled with mineral oil and cooling shall be of oil forced air forced (OFAF) or oil directed air forced (ODAF) type.

Provided that alternate cooling arrangement viz. oil natural air forced (ONAF), or oil natural air natural (ONAN) are also acceptable depending upon unit size.

(iii) provided with two or more cooling radiator banks with suitable number of standby fans and oil pumps.

Provided that the total capacity of coolers for each transformer shall be minimum 120% of actual requirements.

- (e) The transformers shall be suitable for continuous operation at rated MVA on any taps with voltage variation to meet the system requirement.
- (f) The insulation levels for the transformer windings and bushings shall be as per Table 11 under Regulation 45.
- (g) Short circuit withstand test shall be conducted on one of each type and rating of power transformers to validate the design and quality if ordered quantity is more than one (whether three phase or single phase) unless such test has been conducted within last ten (10) years (from the date of placement of order) on transformer of same design.

Provided that in case there is a change in design before ten (10) years, the new transformer design shall be validated by carrying out short circuit withstand test.

- (h) Mobile centrifuging plant of adequate capacity shall be provided for purifying the transformer oil with provision of on-line testing instruments and annunciating panel.

(4) **High tension (HT) switchgear-** (a) Sulphur hexa fluoride (SF<sub>6</sub>) or vacuum type of circuit breakers shall be provided for HT switchgear (11/6.6/3.3 kV) which shall be of draw out type, re-strike free, trip free, stored energy operated and with electrical anti-pumping features.

Provided that the same shall be applicable for 33kV voltage level also in case used.

(b) The protective relays shall be of numerical type with self monitoring, diagnostic features and communication facility.

(c) The switchgear shall be designed for suitable fault withstanding capability.

(5) **Low tension (LT) switchgear-** (a) Air break type of circuit breakers shall be provided for LT switchgear (415 V) which shall be of draw out type, trip free, stored energy operated and with electrical anti-pumping features.

(b) The protective relays shall be of numerical type with self monitoring, diagnostic features and communication facility.

(c) The switchgear shall be designed for suitable fault withstanding capability.

(6) **Busducts**

(a) The busducts shall be of standard size as per relevant IS and designed to carry maximum continuous current under normal site conditions without exceeding temperature rise limits.

(b) (i) The generator busducts shall be phase segregated or isolated phase type.

Provided that the busduct rated more than 3150 Amp and upto 6000 Amp shall be isolated phase type.

Provided further that the busduct rated more than 6000 Amp shall be continuous isolated phase type.

(ii) A hot air blowing system or air pressurization system shall be provided to prevent moisture deposition in case of isolated phase busducts while space heaters may be provided in case of other busducts.

(c) (i) Surge arresters and voltage transformers connected to generator busducts shall be located in separate cubicles for each of the three phases.

Provided that voltage transformers shall be accommodated in draw-out type compartments in phase-isolated manner in a cubicle.

(ii) The surge arresters and voltage transformers cubicles shall comply with relevant IS / IEC Standards.

(d) The HT busduct (11/6.6/3.3 kV) shall be segregated phase type and LT busduct (415V) shall be non-segregated phase or sandwich type.

(e) The bus assembly shall be designed mechanically to withstand rated continuous current as well as the specified short-circuit current without damage or permanent deformation of any part of the bus structure.

(7) **Power supply system**

(a) All auxiliaries dedicated to the unit shall be fed from the unit bus connected to UAT(s).



Provided that during start -up and shut - down of the unit, the unit auxiliaries shall be supplied power from the station bus connected to station transformer(s).

Provided further that in case of GCB scheme, the same shall be provided by the unit bus.

- (b) All the loads pertaining to balance of plant facilities shall be fed from station bus connected to Station transformer(s).

Provided that station bus shall also be capable of supplying power to largest unit in the Station during start-up and shut-down.

Provided further that in case of GCB scheme, the loads pertaining to balance of plant facilities shall be fed from the unit bus or any other common system bus.

- (c) (i) Power supplies, buses, switchgears, interlocks and standby supply systems for station and unit auxiliaries shall be designed in such a way that the equipment connected are not endangered under all operating conditions.

Provided that transformer voltage ratios, type of tap changers and tap ranges, impedances and tolerances thereon shall be so optimized that the auxiliary system voltages under various grid and loading conditions are always within permissible limits and equipment are not subjected to unacceptable voltages during operation and starting of motors.

(ii) The vector groups of the generator transformers, unit auxiliary transformers and station transformers shall be so selected that the paralleling at 11/ 6.6/ 3.3kV buses shall be possible.

Provided that the vector group of auxiliary transformers shall have identical vector groups.

- (d) In thermal power stations with unit sizes greater than 100 MW, automatic bus transfer system (consisting of fast, slow, etc. transfer in auto mode) shall be provided to minimise time for transfer from unit to station buses at 11/ 6.6 kV levels.

Provided that bus transfer scheme shall also have manual mode to initiate transfer including live changeover through synchronisation.

Provided further that the 11/6.6/3.3 kV switchgear buses for balance of plant facilities shall be provided with auto-closure facility to changeover supply from one source to another.

Provided also that critical 415 V switchgear buses shall also have auto-closure facility to changeover supply from one source to another.

- (e) Auxiliary transformers, as required, shall be provided to meet the demand at various voltage levels of auxiliary power systems, with the criteria that each switchgear, motor control centre (MCC), distribution board (DB) shall be fed by 2x100% transformers/ feeders.

Provided that the auxiliary transformers shall be designed to carry the maximum expected load.

Provided further that the LV auxiliary transformers shall be energy efficient as per relevant IS: 1180

- (8) **Neutral earthing-** The earthing of neutral of various systems shall be as follows:

|     |   |   |   |
|-----|---|---|---|
| (a) | Generator star point  | : | Through dry type distribution transformer with secondary loaded with a resistor.  |
| (b) | Generator transformer, Station transformer – high voltage (HV) winding star point | : | Solidly earthed.  |
| (c) | 33kV, 11kV, 6.6kV or 3.3 kV system  | : | Through a resistance in case of star connected windings;<br>or<br>Through artificial transformer with its secondary loaded with resistor in case of delta connected windings. |
| (d) | 415 V system  | : | Solidly earthed.  |
| (e) | DC system   | : | Unearthed.  |

- (9) **Earthing system-** (a) The earthing system shall be designed for a life expectancy of at least forty (40) years and for maximum system fault current or 40 kA for 1.0 sec, whichever is higher.

(b) The minimum rate of corrosion of steel used for earthing conductor shall be considered as 0.12 mm per year while determining the conductor size.

(c) Grounding and lightning protection for the entire Station shall be provided in accordance with relevant IS (Indian Standard)/ IEEE (Institute of Electrical and Electronics Engineers) Standards.

- (10) **Protection system-** (a) Fully graded protection system with requisite speed, sensitivity and selectivity shall be provided for the entire station and shall be designed to avoid mal-operation due to stray voltages.

Provided that the generator, generator transformer, unit auxiliary transformer(s) shall be provided with protection systems connected to two independent channels or groups, such that one channel or group shall always be available for any type of fault in the generator and these transformers.

(b) The electrical protection functions for generator, generator transformer, unit auxiliary transformer(s) and station transformer(s) shall be provided in accordance with but not limited to the list given in Schedule- I.

(11) **Synchronization-** Automatic as well as manual facility alongwith check synchronizing and guard relay features shall be provided for closing of generator transformer/ generator circuit breaker for synchronization of generator with the grid.

Provided that HT auxiliary buses shall also be provided with manual synchronizing facility.

(12) **Power and control cables, and cabling**

(a) (i) Power and control cables shall be flame retardant low smoke (FRLS) type with fire survival (FS) cables to be provided for certain essential auxiliaries.

(ii) Cables to be directly buried shall be essentially armoured type.

(iii) FRLS cables and FS cables shall meet test requirements as per relevant ASTM (American Society of Testing and Materials), IEC, IEEE and SS (Swedish Standards).

(iv) Derating factors for site ambient and ground temperatures, grouping and soil resistivity shall be considered while determining the size of cables.

(b) (i) Cable installation shall be carried out as per relevant IS and other applicable standards.

(ii) Power cables and control cables shall be laid on separate tiers. The laying of different voltage grade cables shall be on different tiers according to the voltage grade of the cables with higher voltage grade cables in topmost tier and control cables in bottommost tier.

(iii) All cables associated with one unit shall preferably be segregated from cables of other units.

(iv) Cable routes for one set of auxiliaries of same unit shall be segregated from the other set.

(13) **Standby power supply system** - (a) Automatic mains failure (AMF) reliable standby power supply system shall be installed for feeding emergency loads in the event of failure of Station supply.

(b) One such supply system shall be provided for each unit of 200 MW and above.

Provided that, in addition, there shall be one common standby such supply system of same rating to serve a block of two units.

(c) Station with a single unit of 200MW or higher rating shall be provided with two (2) no. such supply system of full design capacity.

(14) **DC system-** (i) Standard voltage levels of the DC system shall be 220 volts, 48 volts and 24 volts for control and protection of various equipment.

Provided that 110V DC or 125V DC may be provided for off-site areas and for Gas Turbine as applicable.

(ii) Two sets of batteries, each catering to 100% load, shall be provided for each DC system with one float -cum- boost charger for each set of battery.

(15) **Illumination system-** (i) Adequate illumination shall be provided in accordance with relevant IS.

Provided that emergency AC and DC illumination shall also be provided at important places.

(ii) Energy conservation measures shall be adopted while designing the lighting system.

(16) **Motors-** (a) AC motors shall be squirrel cage induction type suitable for direct on-line starting and shall comply with relevant IS.

Provided that the crane duty motors may be slip ring/ squirrel cage induction type.

(b) DC motors shall be shunt wound type.

(c) All motors shall be either totally enclosed fan cooled (TEFC) or totally enclosed tube ventilated (TETV) or closed air circuit air cooled (CACCA) or closed air water cooled (CACW) type.

(d) Temperature rise shall be limited to 70<sup>0</sup> C by resistance method for both Class- B and Class- F insulation.

(e) The degree of protection of all the motors shall be IP (ingress protection)-55.

Provided that outdoor motors shall be provided with suitable canopies.

Provided further that enclosures of the motors located in hazardous areas shall be flame proof type conforming to relevant IS.

(f) All LT motors shall be of minimum high efficiency (IE2) class as per relevant IS.

## **11. Control and Instrumentation System**

### **(1) General**

(a) Control and Instrumentation system provided for the Station shall be consistent with modern power station practices and in compliance with all applicable codes, standards, guidelines and safety requirements in force.

(b) The complete thermal, mechanical and electrical functions of the unit shall be remotely controlled from the central control room and those of balance of plant facilities shall be controlled from respective local control room during normal as well as emergency conditions.

Provided that the number of control areas shall be kept to the minimum with a view to optimizing manpower requirement.

(c) All standby auxiliaries shall be designed to start automatically as quickly as possible on failure of running auxiliaries as per process requirement.

### **(2) Control system for steam generator and turbine generator**

(a) The state of art microprocessor based distributed digital control, monitoring and information system (DDCMIS) shall be provided for monitoring and control of steam generator, turbine- generator and auxiliaries and shall include monitoring and information, sequential control for drives, closed loop control for regulating drives, interlocking and protection, historical data storage, alarm annunciation system, sequence of events (SOE) recording system etc.

Provided that the DDCMIS shall be independent for each unit.

(b) (i) Control systems integral to steam generator and turbine-generator shall be implemented as part of DDCMIS.

Provided that the turbine protection system and electro- hydraulic governing system may be implemented as per standard practice of turbine manufacturer.

(ii) Control systems integral to steam generator shall include furnace safeguard supervisory system (FSSS) (comprising burner

management system, master fuel trip, mills automation etc.) which shall comply with latest version of NFPA code.

Provided that the master fuel trip (MFT) system shall comply with requirements of relevant NFPA/ VDE (Germany) codes.

(iii) Control systems integral to turbine- generator shall include turbine protection system, electro-hydraulic governing (EHG) system, turbine stress control system, turbine supervisory system, automatic turbine run up system (ATRS) and automatic on load turbine testing (ATT) system.

- (c) Man machine interface (MMI) system configured around latest state-of- art redundant workstations with open architecture shall be provided to operate the unit under all operating conditions.

Provided that the minimum number of hardwired devices shall also be provided for safe shutdown of unit as a back- up.

Provided further that a large video screens (LVS) shall also be provided in the control room.

- (d) DDCMIS shall be provided with 100% redundancy for processors, control and input/ output bus as well as network components.

- (e) (i) All input modules for control, interlocking and protection shall be provided with redundancy.

(ii) Output modules for all HT drives and critical LT drives shall also be provided with redundancy.

(iii) Redundant inputs and outputs shall be connected to different respective input and output cards of DDCMIS i.e. triple redundant inputs shall be connected to three separate input cards.

(iv) The logics for redundant drives shall not be in the same processor.

- (f) The design of the control systems and related equipment shall adhere to the principle of 'fail safe operation' wherever the safety of personnel and plant equipment is involved, where 'Fail safe operation' signifies that the loss of signal, loss of power or failure of any component shall not cause a hazardous condition.

Provided that it shall also be ensured that occurrence of false trips is minimized.

Provided further that no single failure either of component or power source of DDCMIS shall cause loss of generation.

- (g) The control system shall include on-line self-surveillance, monitoring and diagnostic facility providing the details of each fault at the MMI system.
- (h) It shall be possible to remove and replace various modules (like any input module, output module, interface module, etc.) on-line from its slot for maintenance purpose without switching off power supply to the corresponding rack and without jeopardizing safety of the Station equipment and personnel.
- (i) (i) The historical data storage and retrieval system shall store and process system data for future analysis.  
Provided that the data shall be transferable to removable storage media for long term storage and retrieval.
  - (ii) The binary data to be stored shall include status of SOE (1milli-second resolution), alarm and other binary inputs.  
Provided that all the important analog data shall be stored at one second interval.
  - (iii) Selected logs viz. start-up log, trip analysis log shall also be stored.
- (j) Master and slave clock system shall be provided to ensure uniform timing in all the control systems across the entire plant.
- (k) All coal or lignite fired units of size 250 MW and above shall be provided with on-line efficiency monitoring and optimization system to maximize the operational efficiency.

(3) **Control system for balance of plant-** Programmable logic controller (PLC) based or DDCMIS based control system with independent MMI system shall be provided for all the balance of plant facilities like coal or lignite handling plant, ash handling plant, cooling water system, water treatment plant etc.

Provided that the PLCs shall be latest state of the art system with redundant processors.

Provided further that for minor balance of plant systems, the control systems may be relay based.

(4) **Local area network (LAN)-** A redundant industrial grade station-wide LAN shall be provided for information exchange between DDCMIS of each generating unit, PLCs for balance of plant as well as gateway for connecting to the other off-line services of the Station (computerized inventory management, maintenance management systems etc.).

(5) **Communication system-** An effective communication system shall be provided to facilitate quick communication among the operating personnel at various locations of the power station.



(6) **Measuring instruments and systems**

- (a) Instruments such as transmitters, thermocouples, resistance temperature detectors (RTDs), local gauges, flow elements, transducers shall be provided as required for comprehensive monitoring of various parameters of the Station locally as well as in control room(s) through DDCMIS.
- (b) Microprocessor based vibration monitoring and analysis system shall be provided for monitoring and analysis of vibration of critical rotating equipment (i.e. turbine- generator, boiler feed pumps, induced draft (ID)/ forced draft (FD) /primary air (PA) fans etc.)
- (c) On line flue gas analysis instruments including sulphur-di-oxide (SO<sub>2</sub>), nitrogen oxides (NO<sub>x</sub>), oxygen, carbon mono-oxide (CO) and dust emission monitoring systems shall be provided.
- (d) The triple sensors shall be provided for critical binary and analog inputs required for protection of steam generator and steam turbine as well as for critical control loops (e.g. furnace draft, drum level, condenser vacuum).

Provided that redundant sensors shall be provided for other important applications.

- (e) All electrical instruments and devices like switches, transmitters, controllers, analyzers, solenoid valves which are located in the hazardous locations like hydrogen generation plant shall be provided with explosion proof enclosure suitable for hazardous areas as per National Fire Protection Association (NFPA)/ National Electrical Code (NEC).

(7) **Power supply system-** Independent, redundant and reliable 230 V or 110 V AC through uninterrupted power supply system (UPS) and/or DC power supply at standard voltage levels (e.g. 220V/ 48V/ 24V) shall be used for control and instrumentation systems.

(8) **Control valves-** The control valves and accessories shall be designed, constructed and tested as per IBR, ASME code for power cycle piping and ASME boiler & pressure vessel code or equivalent.

(9) **Steam and water analysis system (SWAS)-** An on-line sampling and analysis system shall be provided, as per the recommendation of manufacturers of steam-generator and steam turbine, for continuously monitoring the quality of condensate, feed water, steam etc.

**12. Balance of Plant**

(1) **Coal or lignite handling system-** The arrangement for transportation of coal or lignite from supply source to the Station may be by rail or other captive systems such as merry go round (MGR), belt conveyer system,

ropeway system etc. and the system shall comply with the following requirements:

- (a) The coal or lignite handling plant capacity shall be such as to meet the day's fuel requirement by its operation in 14 hours.

Provided that a day's fuel requirement shall be worked out at 100% BMCR using worst coal or lignite plus a margin of 10%.

- (b) The coal or lignite handling plant shall be provided with 100% standby streams with each stream to be provided with 2x75% or 3x50% paddle feeders (in case of track hoppers) or apron feeders (in case of wagon tippler) and 2x50% crushers with belt feeders.

Provided that single set of coal or lignite conveyers from the stockyard to the bunkers shall not cater to more than three units.

- (c) In case of rail based transportation, marshalling yard for handling of wagons and unloading system shall be designed to facilitate return of empty wagons within the time prescribed by the Indian Railways under the worst seasonal conditions.

- (d) Provision of proper dust suppression facility shall be made for coal at various locations i.e. receiving point, stockyard and discharge points of conveyers to avoid dust nuisance and spontaneous fire.

- (e) The provision for measurement of weight of coal or lignite shall be made through weighbridges at the receiving point.

Provided that the weight of coal or lignite fed to individual units shall also be measured through belt-weighers.

- (f) Magnetic separator system for removal of ferrous materials and detectors for non-ferrous materials shall be provided on the conveyor system.

- (g) Arrangement shall be made for sampling of coal or lignite, and associated instruments/ equipment shall be provided to monitor quality of coal or lignite on as- received basis as well as on as- fired basis before the bunkers.

## (2) **Fuel oil system**

- (a) The capacity of fuel oil storage facilities shall be adequate for the requirement of fuel oil for at least 30 days' operation of the Station.

- (b) Suitable heating arrangement shall be made for heating the heavy fuel oil by steam to maintain its flowability.

- (c) The aspects regarding proper storage and handling of fuel oil shall be as per statutory requirements of Chief Controller of Explosives.
- (d) Suitable measuring and recording facilities shall be provided for quantum of fuel oil(s) received and used.

**(3) Ash handling system**

- (a) (i) Ash management plan for utilization and disposal of fly ash as well as bottom ash shall be formulated in accordance with MOE&F's requirements and any other stipulation of the CPCB and SPCB in this regard.
- (ii) Ash pond management shall be judiciously planned to optimize the land use and facilitate utilisation of pond ash.

Provided that it shall also conform to MoEF&CC requirements and any other stipulation of the CPCB and SPCB in this regard.

*(b) For Pulverised Fuel Based Steam Generator:*

- (i) Arrangement shall be provided for extraction of 100% of fly ash produced and its transportation to silos in dry form.
- (ii) Dry fly ash storage silos of adequate capacity (about 16 hours of ash generation with unit operation at MCR) to collect dry fly ash shall be provided in a separate area near the Station boundary with provision for independent access.
- (iii) In addition to fly ash disposal in dry form, the provision may also be made for disposal through wet slurry system or high concentration slurry system.

Provided that in case of wet slurry system, suitable ash water recirculation system shall be provided to recycle and reuse water.

- (iv) Furnace bottom ash alongwith economizer ash shall be extracted and disposed in wet, semi-wet or dry form.
- (v) The design requirements of ash handling system for pulverised fuel based steam generators shall be as indicated in the Schedule-II.

*(c) For Fluidized Bed Steam Generator:*

- (i) Dry fly ash extraction, transportation and storage system shall meet the requirements as stipulated above for pulverized fuel based system.

- (ii) In addition to fly ash disposal in dry form, the provision may also be made for disposal through wet slurry system or high concentration slurry system.

Provided that in case of wet slurry system, suitable ash water recirculation system shall be provided to recycle and reuse water.

- (iii) Furnace bottom ash shall be extracted in dry form by means of drag link chain conveyor and further disposed in wet, semi-wet or dry form.
- (iv) The design requirements of ash handling system for fluidized bed steam generators shall be as indicated in Schedule- II.

#### (4) **Station water system**

##### (a) *Station Water Scheme*

- (i) The station water scheme shall be designed to meet the total clarified water requirement of the Station consisting of cooling tower make up (for non-coastal stations), de-mineralised water, service water, potable water and miscellaneous requirements.
- (ii) For coastal Stations, sea water shall be used for cooling of condenser and secondary cooling of plate heat exchangers, and clarified (non-saline) water shall be used for de-mineralisation system, service water, potable water and miscellaneous requirements.

Provided that in case non-saline water is not available, sea water shall be used for production of non-saline water through desalination plant.

Provided further that de-silting arrangement and travelling water screens shall be provided at the sea water intake

- (iii) Raw water for production of clarified water shall be drawn from identified source of water and supplied to the Station site by raw water pumps with adequate standby provision and 2x50% or 1x100% capacity pipeline(s).

Provided that provision for de-silting (if required) and travelling water screens shall be made at the raw water intake point.

Provided further that adequate storage of raw water shall be provided at the Station site considering the period of non-availability of input water from the source.

##### (b) *Pre-treatment System*

The raw water shall be treated in pre-treatment plant to produce clarified water for meeting the requirement of clarified water of the Station.

Provided that adequate provisions for raw water chlorination, chemical dosing and sludge handling shall also be made.

(c) *Cooling Water System*

- (i) The cooling water (CW) system for condenser and secondary cooling system for Station equipment shall be clarified water based and shall be of closed cycle type using cooling towers.

Provided that Air Cooled Condensers (ACC) can also be used based on site specific conditions.

Provided further that for coastal Stations using sea water, once through cooling system shall be used which shall conform to MoEF&CC's requirements of temperature rise and any other stipulation of the CPCB and SPCB in this regard.

- (ii) (a) The cooling tower shall be of mechanical induced draft type or natural draft type depending upon site specific techno-economics.

(b) The design wet bulb temperature of the cooling tower shall correspond to the ambient wet bulb temperature which is not exceeded for more than 5% of the time during four summer months in an average year.

(c) Adequate recirculation allowance shall be considered for arriving at design wet bulb temperature for induced draft cooling tower.

- (iii) The design of CW pump house shall be based on sump model studies and hydraulic transient analysis shall be carried out for CW piping system.

- (iv) (a) CW pumps shall be provided on unit basis for supply of cooling water.

Provided that the standby pump(s) may be on unit basis or common to the Station.

(b) The CW pumps shall normally be of vertical wet pit type.

Provided that concrete volute pumps may also be used particularly for sea water applications.

- (v) Chemicals such as chlorine, acid, anti-scalant, biocide shall be dosed in the CW system for improving quality of circulating water and reducing its scaling and corrosive tendency.

(d) *De-mineralisation System*

- (i) (a) The capacity of de-mineralised (DM) plant shall be based on the requirement of de-mineralised water for heat cycle make-up, equipment cooling system make-up, regeneration of DM plant and condensate polishing plant, if envisaged.

(b) The DM plant shall be designed to produce the daily requirement of de-mineralised water of the Station in twenty (20) hours of operation of the DM plant.

(c) Adequate redundancy shall be provided in the number of de-mineralising streams.

- (ii) The demineralized water shall be stored in minimum 2 nos. DM water storage tanks of total storage capacity equal to 24 hour Station requirement.

(e) *Waste Water Treatment System*

The waste water generated at various locations shall be segregated at the source of generation according to its type.

Provided that similar type of waste water shall be collected at one point and suitably treated for reuse in the plant.

Provided further that the treatment of plant waste water shall be in accordance with the statutory requirements.

(5) **Fire detection, alarm and protection system**

- (i) A comprehensive fire detection, alarm as well as fire protection system shall be installed for the Station in conformity with relevant IS.
- (ii) Automatic fire detection and alarm system shall be intelligent and addressable type and shall be provided to facilitate detection of fire at the incipient stage and give warning to the firefighting staff.
- (iii) Major equipment to be used for fire detection and protection system shall be in accordance with relevant IS or UL (Underwriters Laboratories, USA) or FM (Factory Mutuals, USA) or LPCB (Loss Prevention Certification Board, UK) or VDS (Germany).
- (iv) Dedicated fire water storage and pumping facilities of adequate capacities shall be provided for the fire fighting system as per TAC guidelines.

Provided that the main fire water pumps shall be electrically driven and standby pumps shall be diesel engine driven.

- (v) Necessary hydrant system, complying with TAC guidelines, shall be provided at various locations to cover the entire Station.
- (vi) All major and minor fire risks in the Station shall be protected against fire by suitable automatic fire protection systems.

Provided that the following systems shall be generally adopted for various fire risks:

- (a) Every transformer of 10MVA and above rating shall be provided with High Velocity Water Spray System as per IS 15325 or High Pressure Water Mist System as per NFPA 750 or compressed air-foam system as per NFPA 850 or Nitrogen Injection Based System.
- (b) Automatic high velocity water spray system as per IS 15325, shall be provided for the following areas:
  - (ba) Lubricating oil systems including storage tanks, purifier units, coolers, turbine oil canal pipelines;
  - (bb) Generator seal oil system tanks, coolers;
  - (bc) Steam generator burner fronts.
- (c) Steam turbine bearing housing and air pre-heater shall be provided with manually actuated high velocity water spray system.
- (d) Automatic medium velocity water spray system, complying with TAC guidelines, shall be provided for the areas relating to:
  - (da) Cable galleries, cable vaults, cable spreader rooms, cable risers, cable shafts etc.;
  - (db) Coal conveyors, transfer points, crusher houses etc.;
  - (dc) Fuel oil pumping stations;
  - (dd) LDO and day oil tanks;
  - (de) Reliable standby power supply system building.
- (e) Automatic foam system shall be provided for fuel oil storage tanks as per NFPA guidelines.
- (f) Automatic inert gas flooding system, comprising of 2x100% inert gas cylinder batteries conforming to NFPA, shall be provided for Unit control rooms, control equipment rooms and area above false ceiling of these rooms.
- (vii) Portable fire extinguisher as per TAC guidelines shall be provided for each room/area of power station in addition to fixed fire protection system to extinguish fire in its early phase to prevent its spread.
- (viii) Fire station and fire tenders along with trained staff shall be provided for the Station.
- (ix) Passive fire protection measures such as fire barriers for cable galleries and shafts etc., fire retardant coatings, fire resistant penetration sealing for all openings in floors, ceilings, walls etc., fire

proof doors etc. shall be provided to prevent spreading and for containment of fire.

(6) **Compressed air system**

- (a) Compressed air system comprising of instrument air and service air shall be provided to cater to the requirement for operation of various pneumatically operated drives and general purpose cleaning and maintenance services.

Provided that air dryers shall be provided for instrument air to achieve desired dryness.

- (b) At least one number air compressor shall be provided as standby.

(7) **Ventilation and air-conditioning system**

- (a) Suitable ventilation and air-conditioning system shall be provided to achieve proper working environment in the Station.

- (b) (i) Central control room, local control rooms and service building for O&M personnel shall be air conditioned.

Provided that the air- conditioned areas shall be maintained at about 25°C and 50 % relative humidity for comfort conditions.

- (ii) Water chilling unit shall be of 2x100% or 3x50% capacity and condensing units shall be of 2x100% capacity .

Provided that the package type air-conditioners shall have 2x100% capacity or 3x50% capacity equipment.

Provided further that for window air conditioners and split air conditioners, if used for small control rooms, at least one unit shall be kept as standby.

- (c) The type of ventilation systems to be provided, excluding for air conditioned areas shall be as under:

- (i) All floors of TG building, switchgear : Evaporating cooling system rooms and cable gallery

- (ii) Other buildings : Mechanical ventilation system

- (8) **Mill rejects system-** The mill rejects system shall be provided to collect reject from coal mills in case of vertical mills.



Provided that the system shall be of mechanized type i.e. drag chain conveyor or pneumatically pressurized conveying system.

Provided further that the system shall consist of collection of rejects from each coal mill and transport to silos for final disposal.

(9) **Electric overhead travelling (EOT) crane**

- (a) The EOT cranes shall be provided for maintenance of TG cycle equipment and CW pumps.  
Provided that these shall comply with the requirements of latest versions of relevant IS.

Provided further that the crane capacity shall be taken as 5% more than the single heaviest equipment to be lifted by the crane.

- (b) Two EOT cranes may be provided for maintenance of TG cycle equipment in case more than two steam turbine generators are housed in the TG hall.

(10) **Laboratories-** The Station shall be provided with following laboratories:

- (a) Electrical laboratory with necessary equipment and instruments for testing and maintenance of electrical equipment;
- (b) Control and Instrumentation laboratory with necessary equipment and instruments for testing, calibration and maintenance of control & instrumentation systems;
- (c) Chemical laboratories with necessary equipment, instruments and reagents for chemical analysis in water treatment plant, steam & water analysis and analysis of coal, ash & flue gas.

13. **Civil Works-** The design philosophy of civil works shall be based on techno-economics of various options for the construction techniques.

- (1) **Geo-technical investigations-** Geo-technical investigations required for elastic assessment of foundation geology shall be carried out during investigation stage prior to taking up construction activity.

Provided that the geo-technical investigations shall include determination of the sub soil type, ground water table etc., based on which, the type of foundation system, the bearing capacity, the pile parameters, requirement of soil stabilization/ compaction etc., shall be established.

- (2) **Site levelling-** (a)The formation level of the Station shall be kept minimum 1.0 m above the high flood level (HFL) of the site.

- (b) It is preferable to keep the entire Station at the same level.

Provided that to keep the leveling cost to minimum, different levels may be adopted for various blocks.

Provided further that the optimization of excavation and filling quantities may be done while fixing the levels of different blocks.

(3) **Foundations-** (a) Open foundations or pile foundations or a combination of the two keeping in view the lightly/ heavily loaded foundations may be suitably adopted.

Provided that in certain cases, ground improvement and stabilization methods may also be considered.

(b) The foundations for turbines, boiler feed pumps and other rotating equipment shall be suitably designed and the amplitude of vibrations shall be within the limits recommended by the equipment supplier.

Provided that to optimize the foundation system of rotating equipment, 3-D finite element analysis may also be carried out.

Provided further that the following loads shall be considered for the design of foundations, as applicable:

- (i) Load of equipment;
- (ii) Load of other accessories;
- (iii) Dead load of foundation structure;
- (iv) Vacuum load;
- (v) Unbalance forces;
- (vi) Loss of blade force;
- (vii) Short circuit force;
- (viii) Temperature forces;
- (ix) Torque loads;
- (x) Frictional and other longitudinal forces;
- (xi) Live loads;
- (xii) Wind and seismic loads.

(4) **TG and other buildings-** (a) All buildings shall be designed as reinforced cement concrete (RCC) or steel framed super structures with masonry or steel cladding.

Provided that the TG building shall have structural steel framework for super structure with metal cladding on exterior face.

Provided further that other buildings may have RCC or steel framework with masonry cladding of minimum one masonry unit thickness on exterior face.

(b) The design of steel structures shall be as per provisions of latest version of relevant IS.

Provided that composite construction with steel supporting structures and RCC floors may be adopted for the TG and other buildings considering the size, loadings and requirements of construction schedule.

(5) **Structure system-** (a) TG building shall preferably be moment resisting structure in transverse direction and braced in longitudinal direction.

Provided that mill and bunker building shall be provided with moment resisting frame in the transverse direction and braced in longitudinal direction.

(b) The structures shall be designed considering worst load combination of dead loads, superimposed dead loads, imposed loads, design earthquake loads, wind loads etc.

Provided that the superimposed dead loads shall include the loads due to equipment and associated auxiliaries and accessories, duct loads as well as crane loads with impact etc.

Provided further that seismic forces shall be considered as per site specific seismic parameters.

(6) **Architectural requirements-** (a) Overall architectural character of Station building should be in harmony with natural character of environment, climatic conditions and local landscape.

Provided that the interior design should be given due consideration.

(b) The finishing works shall meet the requirements of aesthetics, durability and functional aspects.

Provided that adequate glazing shall be provided for natural light.

Provided further that adequate ventilation shall be provided in all the buildings.

(7) **Chimney-** (a) Chimney may be single flue unitized or multi-flue for two or more units.

(b) The height of chimney shall be decided based on MoEF&CC guidelines and any other stipulation of the CPCB and SPCB in this regard.

(c) Provision of chimney shall also be got cleared by Airport Authority of India.

(d) The size of flue liner shall be decided based on the exit velocity and temperature of flue gases.

Provided that the flues/ flue liners shall be of material appropriate as per flue gas condition and provided with suitable thermal insulation.

Provided further that the portion of flue liner above chimney shall be of acid resisting bricks protected by RCC minishell.

(e) Chimney windshield shall be of RCC construction.

Provided that chimney shall have internal platforms and internal ladder.

Provided further that the top external portion of windshield shall be provided with alternate bands of red and white colour to meet aviation safety requirements.

(f) Chimney shall be provided with liner test port for continuous emission monitoring, lightning protection and grounding system, aviation obstruction lighting and an elevator.

(g) Wind tunnel testing for chimney shall be carried out to optimize the design.

(h) The windshield shall be designed for vertical loading, wind loading, cross wind loading, seismic loading, circumferential wind loading and thermal gradients across the shell.

(8) **Corrosion protection-** Steel structures may be provided with epoxy or polyurethane based painting systems.

Provided that suitable measures shall be provided against corrosion for Stations located in coastal areas.

Provided further that use of special cements, corrosion resistant steel, protective coatings for both concrete and steel are some of the options which can be considered in such conditions.

(9) **Roads and drainage-** The entire area within the Station boundary shall be well connected with a network of roads and drainage system.

Provided that the drains in the Station area shall be designed for maximum rainfall intensity of 50 years frequency.

(10) **Safety provisions-** The safety provisions shall be in conformity with the provisions laid down by National Building Code and other international codes.

## **PART- C**

### **GAS TURBINE BASED THERMAL GENERATING STATIONS**

- 14. Operating Capabilities-** (1) The gas turbine(s) shall be installed alongwith heat recovery steam generator(s) and steam turbine except where intended to be used for emergency, black start or only for peaking duty.
- (2) Combined cycle gas turbine (CCGT) module, comprising of gas turbine generator(s) and steam turbine generator, shall give its MCR output at the specified site conditions and the design fuel.
- (3) The CCGT module shall be capable of base load operation. However, these shall also be capable of load cycling and two-shift operation.
- (4) The gas turbine, steam turbine and all rotating auxiliaries shall be suitable for continuous operation within the frequency range of 47.5 Hz to 51.5 Hz.
- (5) The design of the equipment and control system shall be suitable for operation of the CCGT module in automatic load frequency control.
- (6) Gas turbine rating (ISO) upto 100 MW shall be provided with black start facility.
- (7) The gross heat rate of CCGT module as guaranteed by the equipment manufacturer shall not exceed the following values:

**Table 2**

| <b>Gas Turbine rating (ISO)</b> | <b>Gross Heat Rate of CCGT module (on HHV basis) in kcal/kWh at ISO conditions with natural gas as fuel at 100% load</b> |
|---------------------------------|--|
| 20 MW to 30 MW                  | 2250   |
| > 30 MW to 200 MW               | 1825   |
| > 200 MW                        | 1700   |

- 15. Gas Turbine and Auxiliaries-** (1) The gas turbine and auxiliaries shall comply with latest versions of applicable ISO/ ASME codes.
- (2) The gas turbine compressor shall have a stable aerodynamic characteristic throughout its operating regime.

Provided that the operating point in the entire frequency range of 47.5 to 51.5 Hz shall be sufficiently away from surge line so that it is stable at all conditions of load, ambient temperature and blade fouling.

(3) The compressor shall be provided with variable type inlet guide vanes to meet start up and shutdown requirements, improved part load performance in combined cycle mode of operation and exhaust gas temperature control over a wide range.

(4) Combustion chamber arrangement shall be such as to allow maintenance without dismantling of compressor or turbine section and with minimum dismantling of piping and electrical connections.

(5) NO<sub>x</sub> control shall be either through dry low NO<sub>x</sub> combustor or through steam/water injection and shall be able to achieve the NO<sub>x</sub> level limits stipulated by pollution control authorities.

(6) Combustion system shall be provided with flame detection system for monitoring and protection.

(7) Gas turbine shall be provided with self contained lubrication oil system and control oil system with adequate redundancy for pumps and coolers.

(8) Gas turbine shall be provided with an air intake filtration system along with on-line cleaning system to deliver filtered air of acceptable quality to the gas turbine.

(9) Gas turbine generating unit shall be controlled by an electro-hydraulic governing system with 100% back up.

Provided that all necessary protective devices required for safe operation shall be provided.

Provided further that control system of the gas turbine shall include necessary features to check healthiness of protective devices.

(10) The gas turbine shall be capable of withstanding momentary speed rises upto the over-speed trip limit under transient conditions.

(11) Gas turbines envisaged for dual fuel operation (natural gas as primary fuel and liquid fuel as back-up fuel) shall be capable of on-load fuel changeover from natural gas to liquid fuel & vice-versa automatically or with manual initiation.

(12) All piping, valves and fittings downstream of liquid fuel delivery system and NO<sub>x</sub> water injection system shall be made of stainless steel of suitable grade to avoid corrosion so as to prevent entry of rust into the combustion chamber and mal-operation of stop/ control valves.

(13) Each gas turbine shall be provided with on-line fuel flow metering device to monitor fuel consumption.

**(14) Gaseous fuel conditioning system**

(a) Fuel gas conditioning system of the plant shall be designed to provide required quantity of clean, dry gas at required pressure, temperature and quality suitable for the gas turbine.

(b) The temperature of the gas delivered to the gas turbine shall be at least 20°C higher than hydrate forming temperature or gas dew point whichever is higher.

(c) A chromatograph and analyzer shall be provided for determining the composition and heating value of the fuel gas.

(d) Design of fuel gas system shall be as per the provisions of the latest version of relevant ANSI Standards or equivalent.

(e) The gas leak detection and protection system shall necessarily be provided for enclosed areas.

**(15) Liquid fuel storage and conditioning system**

(a) Liquid fuel storage capacity shall be provided corresponding to 15 days requirement, if liquid fuel is used as the primary fuel.

(b) Liquid fuel storage area shall be at least 90 meters away from the gas turbine.

(c) Liquid fuel unloading, storage and forwarding system shall be designed to comply with all applicable statutory requirements.

**16. Heat Recovery Steam Generator (HRSG) and Auxiliaries**

(1) HRSG shall be suitable for outdoor installation and shall be constructed to form a gas tight envelope to prevent gas leakage.

(2) HRSG shall comply with IBR requirements.

(3) Gas turbine exhaust plenum shall be designed for proper gas velocity and temperature distribution and effective pressure recovery.

Provided that the exhaust system design shall take into account very rapid start-up and shutdown rate of the gas turbine.

(4) Arrangement for mandatory purging of gas turbine exhaust system and HRSG shall be provided in order to eliminate chances of explosion (puffing) for combined cycle plants envisaged for operation on liquid fuel firing.

(5) The design of HRSG shall be based on finned tube heat transfer banks of superheaters, evaporators, economisers etc.

Provided that the fin density shall not be higher than 200 fins/m.

(6) The design of HRSG shall be suitable for direct on line starting along with the gas turbine.

(7) The HRSG shall be designed for single pressure/two pressure/three pressure steam generation based on gas turbine rating and techno-economics.

(8) In the event of loss of feed water, it shall be possible to continue HRSG operation for a short duration till the mode of operation of gas turbine is changed to open cycle or gas turbine is tripped and coasted down.

(9) The gas temperature at HRSG exit, the temperature of condensate entering condensate pre-heater and temperature of feed water entering economiser shall be such as to avoid acid dew point corrosion.

- 17. Steam Turbine and Auxiliaries-** Steam turbine shall be single or multi pressure, condensing type complying with relevant IEC Standards or equivalent.

Provided that other requirements stipulated for coal or lignite based thermal generating stations in Part-B of this Chapter in respect of steam turbine and auxiliaries shall be complied with, as applicable.

- 18. Electrical System-** Electrical Systems shall meet the requirements stipulated for coal or lignite based thermal generating stations in Part-B of this Chapter in respect of Electrical System, as applicable.

Provided that in case of smaller size of generators, the neutral may be earthed through resistance or voltage transformer.

- 19. Control and Instrumentation System-** Control and Instrumentation Systems shall meet the requirements stipulated for coal or lignite based thermal generating stations in Part-B of this Chapter in respect of Control and Instrumentation System, as applicable.

- 20. Station Water System-** Station water system which includes clarified water system, cooling water system, de-mineralisation system, service water system, potable water system, waste water treatment system shall meet the requirements as stipulated in Part-B of this Chapter in respect of Station Water System, as applicable.

- 21. Fire Detection, Alarm and Protection System-** Fire detection, alarm and protection system shall meet the requirements as stipulated for coal or lignite based thermal generating stations in Part-B of this Chapter in respect of fire detection, alarm and protection system, as applicable.

- 22. Civil Works-** Civil works shall meet the requirements as stipulated for coal or lignite based thermal generating stations in Part-B of this Chapter in respect of civil works, as applicable.



Provided that the stack shall be of steel construction and its height shall meet the requirements of MoEF&CC and any other stipulation of the CPCB and SPCB in this regard.

## PART- D

### INTERNAL COMBUSTION (IC) ENGINE BASED THERMAL GENERATING STATIONS

**23. General-** (1) The IC engine based thermal generating stations shall comprise of generating sets (Gen- sets) and associated facilities and these shall use liquid fuel viz. heavy fuel oil, diesel, bio oil or natural gas or a combination of gas and liquid fuel.

(2) The IC engine based thermal generating stations shall be suitable for indoor installations either on pads or on reinforced concrete foundations and smaller IC engine based generating sets (Gen- sets) may be skid mounted.

(3) All the facilities required for receiving and feeding the inputs such as fuel, lubricants, water, air etc. and the control panel and synchronizing panel shall be provided.

**24. Operating Capabilities of IC Engine based Generating Sets (Gen- sets)-**

(1) The Gen- sets shall be capable of base load operation.

Provided that these shall also be capable of load cycling and single shift or two-shift operation.

(2) The IC engine and all rotating auxiliaries shall be suitable for continuous operation within the frequency range of 47.5 Hz to 51.5 Hz.

(3) For grid connected generating stations, design of the equipment and control system shall be suitable for operation of the Gen- set in automatic load frequency control.

(4) The Gen- set shall have auto start, auto loading, auto stop features and capable of parallel operation in the power distribution system with synchronizing facilities.

(5) The gross heat rate of Gen- set as guaranteed by the manufacturer shall not exceed the following values:

(a) **Diesel engine based Gen- sets (four stroke)**

**Table 3**

| Gen- Set Rating | Gross Heat Rate (on HHV basis) in kcal/ kWh at 100% load |
|-----------------|--|
| 100 kW to 1 MW  | 2350   |

|                 |      |
|-----------------|------|
| >1 MW to 3 MW   | 2250 |
| > 3 MW to 10 MW | 2200 |
| >10 MW          | 2150 |

(b) **Diesel engine based Gen- sets (two stroke)**

**Table 4**

| <b>Gen- Set Rating</b> | <b>Gross Heat Rate (on HHV basis) in kcal/ kWh at 100% load</b> |
|------------------------|---|
| 3 MW to 10 MW          | 2000  |
| > 10 MW                | 1950  |

(c) **Gas engine based Gen- sets**

**Table 5**

| <b>Gen- Set Rating</b> | <b>Gross Heat Rate (on HHV basis) in kcal/ kWh at 100% load</b> |
|------------------------|---|
| >1 MW to 3 MW          | 2400  |
| > 3 MW to 5 MW         | 2300  |
| >5 MW                  | 2150  |

**25. IC Engine and Auxiliaries-**(1) The IC engine and auxiliaries shall comply with latest versions of applicable IS/ ISO/ BS (British Standard) or equivalent codes.

(2) Turbo charger, if applicable, shall be of robust construction, suitable of being driven by engine exhaust.

Provided that it shall draw air through air filter and have adequate capacity to suit engine requirements.

(3) The IC engine shall be capable of satisfactorily driving the generator at 10% over load at rated speed for one hour in any period of 12 hours of continuous running for applications other than base load operation.

(4) The IC engine shall be provided with suitable self-starting device.

(5) The IC engine shall be provided with an air intake filtration system to deliver filtered air of quality suitable for the engine.

(6) An engine driven or a separate AC motor driven booster pump shall be provided to deliver the fuel oil from the supply tank through the filters.

Provided that, if required, an AC motor driven fuel oil priming pump shall also be provided to keep the high-pressure system primed for remote and quick starting at any instant.

(7) The IC engine shall be cooled by radiators (engine mounted or remote type) or by heat exchangers using cooling tower.

Provided that in case of remote radiators, low speed axial fans shall be provided to keep the noise level well within acceptable limits.

(8) (a) The IC engine shall be provided with micro-processor based control system.

(b) The governor shall be electronic type complying with latest version of relevant IS.

Provided that an over speed trip mechanism shall be provided to automatically shut off fuel in case the set reaches above 10% of rated speed.

(c) An engine mounted emergency stop push button shall be provided to stop the engine during emergencies.

(9) Lubricating oil system for IC engine shall be of self contained type or a common lubricating oil system may be provided for two or more IC engines.

(10) Crankcase gases shall be piped outside the engine room so that oil fumes do not accumulate on the engine and radiator.

(11) The IC engine shall be furnished with exhaust system comprising of efficient silencers, chimney etc.

(12) NOx level, stack height and noise level shall comply with the guidelines laid down by MoEF&CC and any other stipulation of the SPCB and CPCB in this regard.

**26. Liquid Fuel Storage and Conditioning System-** (1) Liquid fuel storage capacity shall be provided corresponding to 15 days requirement.

(2) Liquid fuel unloading, storage and forwarding system shall be designed to comply with all applicable statutory requirements.

(3) Each IC engine or a group of IC engines installed at one location shall be provided with on-line fuel flow metering device to monitor fuel consumption.

**27. Electrical System-** Electrical requirements stipulated in Part- B of this Chapter shall be complied with for switchgear, transformers, cables, protections etc. as applicable.

Provided that in case of smaller size of generators, the neutral may be earthed through resistance or voltage transformer.

28. **Control and Instrumentation System-** Control and Instrumentation Systems shall meet the requirements stipulated for coal or lignite based thermal generating stations in Part-B of this Chapter in respect of Control and Instrumentation System, as applicable.
29. **Station Water System-** Station water system shall meet the requirements as stipulated for coal or lignite based thermal generating stations in Part-B of this Chapter in respect of Station Water System, as applicable.
30. **Fire Detection, Alarm and Protection System-** Fire detection, alarm and protection system shall meet the requirements as stipulated for coal or lignite based thermal generating stations in Part-B of this Chapter in respect of fire detection, alarm and protection system, as applicable.
31. **Civil Works-** Civil works shall meet the requirements as stipulated for coal or lignite based thermal generating stations in Part-B of this Chapter in respect of civil works, as applicable.

Provided that the stack shall be of steel construction and its height shall meet the requirements of MoEF&CC and any other stipulation of the CPCB and SPCB in this regard.

### CHAPTER-III

#### TECHNICAL STANDARDS FOR CONSTRUCTION OF HYDRO-ELECTRIC GENERATING STATIONS

32. **Preliminary**
  - a. This Chapter stipulates the minimum technical requirements for construction of Hydro-Electric Generating Stations for various types of schemes i.e. Run-of-river scheme, Storage scheme, Pumped Storage scheme, Canal head scheme etc. with installed capacity of 25MW and above.
  - b. For Hydro-electric generating stations having installed capacity less than 25 MW, the stipulations as appropriate, shall apply.
33. **General Requirements**
  - (1) While designing hydro-electric projects, the life of the civil works shall not be less than one hundred (100) years, while that of main electro-mechanical generating equipment i.e. turbine, generator, transformers, auxiliaries, etc. installed shall not be less than forty (40) years with regular inspection and required maintenance.
  - (2) The station shall be designed for unconstrained operation within the range of maximum net head and minimum net head, specified silt conditions wherever applicable and full range of ambient and other environmental conditions.

- (3) The dimensions of the power house, turbine setting, speed rise, pressure rise, run-away speed, etc. shall be governed by the limits specified in relevant IS.
- (4) a. The chemical analysis of water and silt data including the petrographic and petrofabric analysis shall be taken into consideration while designing the turbine, main inlet valve and other auxiliary equipment susceptible to abrasive effects of silt.
  - b. Suitable materials, protective coatings and painting shall be provided to resist silt abrasion wherever required as per the site conditions.
- (5) The generating units of rated capacity 50 MW and higher shall be capable of operation in synchronous condenser mode, wherever feasible.
- (6)a. The operation of the unit shall be smooth and quiet.
  - b. The noise level shall not be more than 90 dBA at a distance of 1 metre from any equipment when operating near rated output.

#### **34. Layout Considerations**

- (1) General layout of the station shall be developed considering the proper utilization of space, functional requirements, future extensions and considering requirements of space during construction stage.
- (2) Maintenance facilities shall be provided as required for assembly, disassembly and handling during maintenance of all important equipment and auxiliaries.
- (3) a. Fire escape staircases and galleries shall be provided in main station building and Cavern.
  - b. Each equipment room shall be provided with alternate exits to be used in case of fire or accidents, as per requirements of the Factory Act and other statutory requirements.
- (4) a. Adequate provisions in layout shall be made for protection of power house against flooding.
  - b. The required provisions for protection against flooding are given in Regulation 39.

#### **35. Operating Capability of the Generating Unit**

- (1) The unit shall be capable of giving the rated output continuously as specified by the manufacturer at the rated design head and rated discharge and shall be capable of operating between the minimum and maximum head specified by the purchaser and ambient temperature at site as specified.
- (2) The maximum continuous overload capacity up to 110% of rated capacity of the unit at the generator terminals during the high head

conditions or high discharge conditions or both as guaranteed by the manufacturer shall be based on hydraulic parameters of the stations.

- (3) The generating unit and its auxiliaries shall be suitable for continuous operation without any restriction within a frequency range, voltage range and combined variation of voltage – frequency as specified in latest Central Electricity Authority (Technical Standards for Connectivity to the Grid) Regulations and its Amendments.
- (4) a. Provision shall be made for starting the machine in auto mode up to synchronization by a single command and loading of the unit to full load quickly.  
b. The design of the equipment and control system shall permit participation of the unit in automatic frequency control mode.
- (5) The unit and all its associated auxiliaries shall be designed for trouble free operation up to maximum rating of the unit for the complete range of operation for active power and reactive power output.
- (6) The unit and its auxiliaries shall be designed to operate for the silt levels and its characteristics specified for the project, based on the historical water inflow data of the river.
- (7) The redundancy in the unit auxiliaries and station equipment shall be provided so that the generating unit continues to operate even in the event of outage of a part of the auxiliary system.
- (8) The station shall be equipped with facilities for black start of one generating unit at a time in the event of grid black-out conditions. However, for stations with variable speed machines, the facility of black-start shall be provided wherever feasible.

### **36. Hydraulic Turbines and Auxiliaries**

- (1) The hydraulic turbine shall comply with latest versions of relevant IS or IEC standards.
- (2) a. Turbine shall have smooth and quiet operation.  
b. The vibrations, pressure pulsations and power fluctuations shall be within the limits specified in relevant standards.  
c. The amplitude of the vibrations at the shaft shall not exceed the limits specified in relevant NEMA or ISO standards.
- (3) a. The type and rotational speed of the turbine shall be selected considering the range of head, specific speed, head variation etc.  
b. In case two different types of turbines are found suitable for the range of head envisaged (overlapping zone of net head) at a particular site, the

selection of turbine shall be based on the techno economic considerations taking into account the aspects such as head variation, civil costs, part load operation, operation and maintenance, efficiency etc.

- (4)
  - a. The rated speed resulting in even number of pair of poles shall be preferred.
  - b. In case of high silt content, at least one step lower synchronous speed shall be selected.
- (5)
  - a. Before the manufacturing of the prototype turbine is taken up, homologous scale model of the prototype turbine shall be made, if not already available, and tested by manufacturer's Laboratory or NABL or APLAC or ILAC accredited independent third party to demonstrate that the prototype turbine will meet the guaranteed performance in respect of efficiency, output, smooth operation, pressure pulsations and other guarantees as stipulated in the technical specifications.
  - b. For power station size up to 100 MW, Computational Fluid Dynamics (CFD) can be used to demonstrate that the prototype turbine will meet the guaranteed performance in respect of efficiency, output, smooth operation, pressure pulsations and other guarantees.
- (6)
  - a. The weighted average efficiency shall be computed based on the efficiencies at various outputs.
  - b. The weightage factors shall be selected corresponding to the average duration or period (in percentage) in a year, for which the units are expected to be operated at different outputs.
  - c. The weighted average efficiency obtainable shall not be less than 93% for Francis, 92% for Kaplan and Bulb turbines and 91% for Pelton and Deriaz turbines.
  - d. The peak efficiency at rated conditions shall be higher than 94% for Francis, 93% for Kaplan & Bulb and 91.5% for Pelton, Deriaz & Propeller turbines.
  - e. The weighted average efficiency of the turbine shall be determined after the installation and commissioning of the generating units on the basis of field acceptance tests on one of the units as per relevant IS or IEC standards.
- (7) The minimum load for continuous operation for various types of turbines shall be as per Schedule-III.
- (8) The pressure rise and speed rise of turbine shall be within the range specified by relevant Indian standards.
- (9)
  - a. The turbine shall be designed to withstand runaway speed for 15 minutes with cooling water on and intact without causing any residual detrimental effect on future operation of the machine.

- b. However, critical speed of the machine shall be around 25% higher than maximum runaway speed.
- (10) Provision of runner removal from bottom for maintenance shall be made, wherever feasible. However, for pumped storage plants, either side removal at turbine pit or top removal from stator bore of runner shall also be acceptable.
- (11) a. The setting of reaction turbine, i.e. centre line of runner, with reference to minimum tail water level shall be governed by cavitation consideration.
- b. Based on the calculations, the centre-line of the runner may work out to be either above or below the minimum tail water level.
- c. Pelton turbine shall be installed with its centre line at a height of minimum one runner pitch diameter above the maximum tail water level or as per the recommendations of the manufacturer.
- (12) a. Special care shall be taken to select the material of the underwater parts.
- b. The materials selected for runner, guide vanes, runner chamber, upper draft tube cone, etc. shall have high wear resistance, corrosion and cavitation resistance.
- c. Besides, the use of the material having good weldability shall be considered so that parts can be fabricated and the eroded parts can be repaired easily at site.
- (13) As most of the rivers in the Himalayan region carry high silt which erodes the runner and under water parts of a turbine at a comparatively faster rate, appropriate protective coatings shall be provided for these parts of a turbine in order to minimize silt erosion, wherever necessary and feasible.
- (14) The guide-vanes, runner, discharge ring and other hydraulic passages shall be designed for a life of 8000 hours against excessive pitting caused by cavitation.
- (15) a. The pump turbine shall be capable of giving output higher than the rated output while operating in the turbine mode.
- b. The pump turbine shall be hydraulically designed giving preference to its operation in "Pumping Mode" so that optimum efficiencies are obtained in both turbine and pump mode.
- (16) The centre line of a pump turbine shall be fixed corresponding to pumping operation.
- (17) Each penstock or hydro turbine shall have online water flow measurement system for unit size higher than 100 MW.



### **37. Governing System**

- (1)
  - a. Microprocessor based digital governing system shall be used for regulating the flow of water to the turbines for the control of active power (MW) thus providing the requisite speed or frequency control and load control.
  - b. The speed sensing device shall be provided with the requisite redundancy.
  - c. The performance requirements of the governing system shall be governed by relevant IS or IEC standards.
- (2)
  - a. High pressure oil system shall be provided for each turbine for the operation of wicket gates or nozzle and deflector servomotors through governors and for the control of main inlet valve (MIV).
  - b. Piston type accumulator integrated with nitrogen bottles shall be used for pressures higher than 60 kg/cm<sup>2</sup>.
- (3)
  - a. Separate oil pressure systems shall be used for the control of turbine and the control of MIV.
  - b. Online oil filtration unit shall be used with servo valve based governing system.
- (4)
  - a. The sizes of various components of oil sump tank and pressure receiver shall be calculated as per the relevant IS or ASME standards.
  - b. The oil volume below its machine shutdown level shall be sufficient to perform 3 full operations of the servomotor viz. Close-Open-Close with oil pumps being out of operation for control of Turbine and one open operation of MIV.

### **38. Main Inlet and Penstock Protection Valve**

- (1) The main inlet valve of either butterfly or spherical type shall be provided depending on head conditions.
- (2) The spherical and butterfly valves shall comply with the requirements of latest versions of relevant IS or IEC standards.
- (3) The valves shall have service seal on downstream side and maintenance seal on upstream side.
- (4)
  - a. The opening and closing of spherical or butterfly valves shall normally be done under balanced water condition.
  - b. Suitable number of air release valves and anti-vacuum valves shall be provided at the appropriate location on the downstream side to allow the air trapped in the Penstock to escape when it is filled with water through the bypass valves and for supplying or admitting the air when the valve is suddenly closed.

- (5) The main inlet valve (butterfly or spherical valve) shall be provided for emergency closure in case of any eventuality including turbine speed increasing to runaway speed with counter weight only.
- (6)
  - a. The penstock protection valve (PPV) shall be provided after the surge shaft as a second line of defence in the projects having the length of Head Race Tunnel 5000 m or more.
  - b. The valve shall be designed for penstock rupture condition.
- (7) The PPV shall be provided with counter-weight for closing. Additional feature of oil assistance closing as back up shall also be provided for emergency closure.
- (8) As far as possible, Main Inlet and Protection valve shall be provided and wherever it is not possible to provide such valves, ring gates or quick closing type intake gates shall be provided.

### **39. Mechanical Auxiliaries**

#### **(1) Electric overhead travelling (EOT) cranes**

- (a)
  - i) The EOT cranes shall comply with the requirements and standards of latest versions of relevant IS or IEC standards.
  - ii) The span of the crane shall be fixed in such a way that the travel and lift of the main and auxiliary hooks of the crane as well as the hook limits shall be adequate for the assembly and disassembly of the main equipment in the power house.
  - iii) The lift above the service bay (upper limit) shall be adequate to hoist and carry the rotor of the generator and to assemble and disassemble the transformer.
  - iv) The lift below the service bay (lower limit) shall be fixed in such a way as necessary for assembly and disassembly of the turbine.
- (b)
  - i) The crane capacity shall be kept as 5% more than the maximum weight to be lifted inclusive of the weight of the lifting beam.
  - ii) If the maximum weight to be lifted is more than 300 Tonnes, two cranes each of equal capacity shall be deployed to lift the heaviest package in tandem operation.
- (c) The provision of radio remote control and variable voltage variable frequency (VVVF) drive for various crane motions for the purpose of precise speed control shall normally be made for cranes having capacity 100 Tonnes and above.
- (d)
  - i) The radio remote control equipment, wherever provided shall conform to all applicable Government rules and regulations.

- ii) The frequency of operation shall be in the requisite frequency band as per relevant standards.
- (e) A monorail of adequate capacity can be provided for handling smaller packages, equipment and sub-assemblies and shall have larger reach than main crane.

## **(2) Cooling water system**

- (a)
  - i) The cooling water requirements of generator air coolers, shaft seal, turbine and generator bearings of each unit and generator transformer shall be met either by pumping the water drawn from the tail pool or draft tube or providing a penstock tapping for the same.
  - ii) The penstock tapping shall not be considered in case of high head installations i.e. where the penstock pressure is more than 10 kg/cm<sup>2</sup>.
  - iii) If the penstock pressure is upto 10 kg/cm<sup>2</sup>, a suitable pressure reducer depending on the requirement of net cooling water pressure (usually 3 to 5 kg/cm<sup>2</sup>) shall be provided.
  - iv) However, as far as possible the penstock tapping for cooling water requirement shall be avoided.
- (b) In the projects where rivers have silt laden water, closed circuit cooling water system shall be provided.

## **(3) Dewatering and drainage system**

- (a)
  - i) Submersible type of dewatering pumps shall be provided to pump out the water trapped between the penstock gate or main inlet valve and draft tube gate in case of Francis and Kaplan turbines to the dewatering sump when maintenance on the turbine of any unit is required to be carried out.
  - ii) The capacity of the pump shall be chosen in such a way that a single unit can be dewatered within 6 hours of operation without raising the level in the sump with the main pump(s) in operation. In addition, standby pump(s) of capacity 50% of the main pump(s) shall also be provided.
- (b)
  - i) All the drainage water within the power house shall be collected inside the drainage sump constructed near the dewatering sump.
  - ii) The drainage water shall be allowed to flow out to the tail race above the maximum flood water level using pumps, if required.
- (c)
  - i) The drainage and dewatering sumps shall be inter-connected by means of gate valve and non-return valve, which allows the flow of water from the drainage sump to the dewatering sump only.
  - ii) The spindle of the gate valve shall be extended up to the turbine floor so that it is possible to operate it from the turbine floor.

- (d) i) A suitable pressure hatch shall be provided to prevent any flow of water from dewatering sump into the power house.
- ii) Drainage sump shall not have any pressure hatch.

#### **(4) Ventilation and Air-conditioning system**

- (a) A ventilation and air-conditioning system shall be provided to achieve proper working conditions inside the power house complex, to serve the purposes such as prevention of temperature stratification, removal of contaminated air, removal of waste heat from equipment as well as to provide fresh air necessary for human comfort with regard to temperature, humidity, and oxygen content, and to extract or force out smoke and other toxic gases during fire.
- (b) i) Ventilation system for circulation of natural air and exhaust shall be provided as a minimum requirement.  
ii) Cooling of air, wherever required, may be provided by evaporating, water cooled cooling tubes or chiller units.
- (c) i) The control room, relay room, PLC room, offices, reception, conference room etc. shall be air-conditioned.  
ii) The conditioned air shall be about 25°C at around 50% relative humidity for comfort conditions.  
iii) A choice of installation out of 3 different types of installations i.e. window or split type, package type or centralized air conditioning plants shall be made on the basis of the required tonnage and suitability of the installation at that particular location.

#### **(5) High pressure and low pressure compressed air system**

- (a) The Nitrogen (N<sub>2</sub>) system having Piston type accumulator shall be provided for pressure 60 kg/cm<sup>2</sup> and more. The high pressure compressed air can also be opted for lesser pressure requirement of turbine governing system and MIV, where the pressure of HP air compressor shall be 1.1 times the working pressure.
- (b) Low-pressure (LP) compressed air system shall be provided to meet requirements such as inflatable rubber seal of shaft glands, operation of pneumatic tools, cleaning, generator braking and jacking, boosting pressure in the fire protection hydro-pneumatic tank, pneumatic detection line for the operation of deluge valve provided for the generator transformer, etc.
- (c) A separate compressed air system, wherever required, shall be provided to supply the compressed air for depressing the water level in the draft tube below the runner to run the machine in synchronous condenser operation mode and pump mode.

#### **(6) Power House lift**

- (a) The lift and its associated equipment shall comply with the requirements of latest versions of relevant IS.
- (b) A minimum of one lift shall be provided in the power house besides two sets of staircases for the movement of persons or goods.

**(7) Oil handling and purification system**

- (a)
  - i) The insulating oil required in the generator transformers for the hydro station shall conform to relevant IS.
  - ii) The type of turbine oil used as a working fluid in speed regulation system and as a lubricant and a coolant for thrust and guide bearings shall be as per the recommendations of the equipment manufacturer. The oil type shall be same for bearing and governor.
- (b) The oil handling system for each grade of oil shall incorporate two tanks (one for pure oil and another for used oil), associated piping and control equipment.
- (c)
  - i) The oil handling facilities shall be located within the power house or in an isolated building outdoors.
  - ii) To convey the oil to the turbines, generators and transformers, suitable oil pipes shall be laid within the power house.
  - iii) Portable type pumps and purifiers and standard oil drums may also be used for hydro-electric stations of installed capacity up to 100 MW.

**(8) Fire fighting system**

- (a) *General*
  - (i) The state of the art fire detection, alarm and protection system shall be provided for the station. The fire protection system as well as hydrant system shall be designed complying with the guidelines of National Fire Protection Association (NFPA).
  - (ii) All major and minor fire risks in the Station such as transformers, cable galleries or shafts, control rooms etc. shall be protected against the fire by suitable automatic fire protection systems. The state of the art automatic fire detection and alarm system shall be provided to facilitate detection of fire at the incipient stage and warning to fire fighting staff.
  - (iii) Portable and mobile fire extinguishers shall be provided to extinguish fire in the initial stage to prevent its spread.
- (b) The transformers or reactors of 10 MVA and higher rating or oil filled transformers or reactors shall be provided with automatic high velocity water spray system as per relevant IS or Nitrogen injection based fire protection system. The transformers or reactors of 400 kV or higher

voltage may be provided with Nitrogen injection based fire protection system in addition to automatic high velocity water spray system.

- (c) The provision shall be made for water sprinkler system for oil plant rooms, especially in an underground power house. In addition, provision shall also be made for fire hose cabinets and hydrants inside the power house as well as for the transformer area. The water supply for the permanent fire protection installation should be based on the largest fixed fire suppression system demand plus the maximum hose stream demand of not less than 1890 L/min for a 2-hour duration. Two nos. of fire pumps, each capable of pumping water to fill the overhead water tank in 6 hours time shall be provided.

#### **(9) Equipment for Mechanical Workshop**

- (a) Mechanical Workshop equipment shall be provided for essential maintenance work and onsite repairs in line with specific project requirements.

### **40. Electrical System**

#### **(1) General requirements**

- (a) For the purpose of design of equipment or systems, an ambient temperature of 40°C or higher as applicable to station site and relative humidity of 95% shall be considered.
- (b) The overall system shall be designed considering maximum voltage and combined variation of voltage and frequency as specified in latest Central Electricity Authority (Technical Standards for Connectivity to the Grid) Regulations and its Amendments.
- (c)
  - i) The telecommunication system shall be based on optical fibre or power line carrier communication (PLCC) or both.
  - ii) Owner's telecommunication equipment provided to transmit the required data of the station to the procurer of electricity, Regional & State Load Despatch Centre and Transmission Company, shall have matching equipment and compatible communication protocol with the receiving end.

#### **(2) Generator/ Motor - Generator**

##### **(a) General**

- (i) The generator shall comply with the requirements of the latest versions of IS or IEC standards.
- (ii) Insulation shall be of thermal class F for the stator and the rotor windings with temperature rises at maximum guaranteed continuous output limited to that of thermal class B as per relevant IS or IEC standards.

- (iii) The generator shall be capable of safely withstanding the maximum stresses during normal operation, run-away speed conditions, two phase and three phase short circuit conditions, single phase earth fault, 180 degree and 120 degree out of phase synchronization, magnetic unbalance with 50% of the poles short circuited within the speed of range of 1.3 times the rated speed, brake application etc.
- (iv) a) The construction of the generator shall be such that the rotor poles and stator coils can be handled out or in without removal of the rotor and without disturbing the upper bearing bracket wherever feasible. However, this may not be applicable to variable speed machines.
- b) The rotor poles shall be interchangeable.
- (v) The output of motor generator shall match with the input required for pumping operation in the operating head range.
- (vi) i) The generator rated speed shall match the rated speed of the turbine or the pump-turbine.
- ii) A rated speed resulting in even number of pair of poles shall be preferred.
- (vii) The current flowing in stator slot shall be limited to 3250 - 6500 Amperes with current through individual coil being limited to approximately 3250 Amperes.
- (viii) The power factor and the requirements of reactive power capability shall be specified as per requirement of latest Central Electricity Authority (Technical Standards for Connectivity to the Grid) Regulations and its Amendments.
- (ix) Metal oxide surge arresters of suitable rating shall be provided for surge protection of generators.
- (x) i) Resistance temperature detectors (RTD) or any other type of temperature sensors at suitable locations, for temperature monitoring of stator core, stator winding and bearings, shall be provided.
- ii) Suitable arrangement for rotor winding temperature monitoring shall also be provided.
- (xi) The inertia of the machine shall be as per the transient stability studies required for the interconnected electrical power system to limit speed rise, pressure rise in waterway and negative pressure in Draft Tube and shall not have such a value which will cause the machine natural frequency to be in resonance with the expected frequency of draft-tube hydraulic surges. A margin of approximately 25% shall be provided for this.

- (xii) Weighted average efficiency based on the computed efficiencies at various outputs for which the generator is expected to operate shall be more than 98% for machine greater than 30 MVA.
- (xiii) Wherever required, dynamic braking shall be provided for generators in addition to mechanical brakes.
- (xiv) Synchronous or asynchronous type generators shall be considered for Pumped Storage Plants with fixed or variable speed drives as per relevant IS or IEC.

(b) *Bearing Arrangements*

- (i) The prudent practice and recommendation of manufacturers shall be considered while deciding the bearing arrangement.
- (ii) a. Combined thrust and upper guide bearing mounted on a top bearing bracket above the rotor and lower guide bearing below the rotor shall be used for small diameter, long core, high speed machines. For medium to high capacity machines having low speed, combined thrust and guide bearing mounted on a separate bearing bracket located below the rotor and an upper guide bearing installed above the rotor on a separate, light weight bracket mounted on the top of the stator frame shall be provided.
- b. The arrangement of combined thrust and guide bearing mounted on a separate bearing bracket located below the rotor shall be used for low to medium capacity machines having low speed.
- (iii) The horizontal mounted hydro-electric machines shall be provided with the journal type bearings. The number of journal bearings shall vary depending upon the machine output, speed, diameter, core length, etc.
- (iv) The limiting temperature of the thrust bearing metal of hydro-electric machines shall be 80°C. The guide bearing temperature limit shall be 70°C.

(c) *Fire Protection System for Generator*

- a. Either water based or CO<sub>2</sub> type of fire suppression system shall be provided.
- b. A water based system shall be adopted in underground power stations because release of CO<sub>2</sub> gas in an underground installation shall be hazardous.

(d) *Generator Busduct*

- (i) a. The generator busduct shall comply with the requirements of the latest versions of relevant IS or IEC standards.
- b. Generator busduct shall be segregated or isolated phase type.



- c. Busduct rated more than 3150 Amperes shall be isolated phase type. The isolated phase ducts shall be preferred over the segregated phase bus ducts.
  - d. Generator Busduct rated more than 6000 Amperes shall be continuous isolated phase type.
  - e. A hot air blowing system or air pressurization system can be provided to prevent moisture deposition in case of isolated phase ducts while space heaters may be provided in case of other busducts.
- (ii) The busduct shall be designed to carry maximum continuous current under normal site conditions without exceeding temperature rise limits. Based on these requirements standard size of busduct as per relevant IS or IEC standards shall be used.
  - (iii) The bus assembly shall be designed to mechanically withstand a rated continuous current as well as the specified short-circuit current without damage or permanent deformation of any part of the bus structure.
  - (iv) The surge arrester and voltage transformer (SAVT) cubicle shall meet the requirements of relevant IS or IEC standards.
  - (v) The generator circuit breaker, as per relevant IS or IEC, shall be provided for Pumped Storage schemes. The circuit breaker shall be suitable for rupturing the line charging current.
- (e) *Generator Neutral Grounding Terminal Equipment*
- (i) a. Generator neutral grounding equipment shall be designed taking into account the maximum permissible operating voltage of the generator, voltage rise on load throw off (subsequent to detection of earth fault) field suppression time, ferro- resonance, etc.
  - b. System earthing shall be such that it shall be possible to provide earth fault protection with proper discrimination i.e. in order to identify that the protection provided is able to identify it as an earth fault.
  - (ii) All large hydro-electric machines having a wye-connected stator winding with the neutral brought out of the machine housing shall be grounded via a high-resistance circuit consisting of a single-phase grounding transformer connected between the generator neutral and ground having a standard high voltage rating equal to the maximum machine phase to phase terminal voltage.
- (f) *Instrument Transformers*
- (i) The current transformers shall be window type fitted around the bus conductors for meeting the protection and measuring requirements.
  - (ii) The voltage transformers shall be located in separate cubicle for each of the three phases and mounted in withdrawable cabinets.

- (iii) The surge diverters or the surge capacitors shall be provided in the same cubicle as that of the voltage transformers with suitable barriers.
- (g) *Machine Condition Monitoring Systems*

The following monitoring equipment or systems for prediction of abnormality and preventive action shall be provided for the generating units rated for 100 MW and above:

- (i) *Air Gap Monitoring*- In order to provide high degree of dimensional stability, online air gap monitoring system shall be provided. A uniform air gap under all the conditions of operation below a tolerance of  $\pm 10\%$  shall be maintained.
- (ii) *Vibration monitoring*- The vibration of bearing and rotor shaft while the units are running shall be monitored by using on-line vibration monitoring equipment for replicating the forces acting on the rotor and bearings.

### **(3) Excitation system**

#### **(i) Fixed Speed Machine**

- (a) i) Static high initial response rectifier excitation system shall be used. Static rectifier excitation system shall obtain the necessary electrical power directly from the terminals of the generator.  
  
ii) The system shall consist of a power transformer, thyristor control element, electronic regulator and de-excitation unit.
- (b) The capacity of the excitation system shall be adequate to supply continuously 1.1 times the excitation current and voltage required by the generator at its maximum continuous output and 100% rated voltage and also for supplying twice the excitation current required by the machine at its maximum continuous output and 110% rated voltage for a duration of one minute.
- (c) The excitation system while operating at its maximum output, terminal voltage, power factor and speed shall be capable of changing from rated field voltage to 90 percent of ceiling voltage within 25 milliseconds for a sustained drop in generator terminal voltage of 5 percent.
- (d) i) The number of bridges shall be such that one bridge is always available as redundant. With the failure of two bridges it shall be possible to continue operation at reduced load.  
  
ii) The rectifier PIV (peak inverse voltage) rating shall not be less than four times the maximum RMS voltage of the input.
- (e) All the performance requirements of the automatic voltage regulation (AVR), power system stabilizer (PSS) shall be in accordance with relevant IEEE standards or latest Central Electricity Authority (Technical Standards for Connectivity to the Grid) Regulations and Central

Electricity Authority (Grid Standards) Regulations and their Amendments.

**(ii) Variable Speed Machine (with Synchronous and Asynchronous Operation)**

- (a) For Pump Storage Plants, AC excitation system shall be provided for asynchronous machines and Static Frequency Converter (SFC) system for synchronous machines.
- (b) The sizing of Excitation Transformers shall be decided based on excitation requirement of Generator. Sufficient redundancy of converters shall also be ensured.
- (c) The variable speed electronic equipment will be adequate for starting purposes. There will be no need for additional starting equipment.
- (d) The synchronous machines shall comply with clauses 37 (3) (i) - (b), (c) & (e) of these regulations.
- (e) The asynchronous machines shall comply with the latest Central Electricity Authority (Technical Standards for Connectivity to the Grid) Regulations and their amendments on various aspects including rated output delivery in frequency range of 49.5 Hz to 50.5 Hz, voltage range of + 5 % and power factor of 0.95 (lag) to 0.95 (lead), remain connected to grid as per the specified voltage-time curve or table during fault or low voltage conditions and high voltage conditions, and active-reactive power control. It shall also comply to the latest clause 37 (3) (i) (e) of these regulations.

**(4) Generator step-up transformers**

- (a) The generator transformers shall comply with the requirements of the latest versions of the relevant IS or IEC standards.
- (b) i) Water cooled transformers wherever feasible, shall be preferred and the type of cooling shall be generally oil forced, water forced (OFWF) or oil directed, water forced (ODWF).  
  
ii) In case, provision of water cooling is not feasible, oil forced air forced (OFAF) or oil directed, air forced (ODAF) type generator transformers shall be provided.
- (c) i) Selection of single phase or three phase transformers for hydro power stations shall be governed by the transportation limitations and shall be finalised considering the status of load carrying capacities of bridges, culverts etc. enroute.

- ii) In case of single phase transformers, one no. transformer shall be kept as spare for power plants having three and more generating units.
- (d) Generator Transformers shall be suitable for continuous operation at rated MVA on any tap with voltage variation in accordance with relevant IS or IEC standards.
- (e) Generator Transformer rating for pump turbine shall be sized according to higher of motor input power or continuous maximum rating of Generator.
- (f) The generator transformers with OFWF or ODWF type cooling shall be provided with two complete independent sets of cooling equipment each with 100% capacity and the generator transformers with OFAF or ODAF type shall be provided with adequate number of coolers with one cooler as standby.
- (g) i) Provision of "Off-circuit" tap changer shall be made for generator-transformers of conventional generating units.  
 ii) On load tap changer may be considered for pumped storage schemes having reversible units.  
 iii) The range of operation for the tap changer shall be governed by the power system requirements.
- (h) i) Surge arrester shall be provided on the high voltage side of each transformer in case of transformers located in open area.  
 ii) For transformers located in cavern, the requirement of the surge arrester characteristics, their number and exact locations shall be decided based on the insulation co-ordination studies.
- (i) Insulation levels for the transformers windings and bushings shall comply with the requirements indicated in Table 10 under Regulation 43.
- (j) Firewalls shall be provided as per the guidelines of BIS.
- (k) The generator transformers having three phase rating of 120 MVA and above shall be provided with on line dissolved gas analyzer system.
- (l) Short circuit withstand test shall be conducted on one of each type and rating of generator transformers to validate the design and quality unless such test has been conducted within last ten years on transformer of same design. In case there is a change in design before ten years, the new transformer design shall be validated by carrying out short circuit withstand test.

## **(5) Unit auxiliary and station auxiliary AC supply systems**

### *(a) Unit Auxiliary AC Supply System*

The auxiliary supply system of each generating unit shall be provided with unit auxiliary transformer to feed the loads of the unit. The unit auxiliary transformers, dedicated for each unit, shall be provided for supplying power to various unit auxiliaries from the unit to which these are connected. The essential load consists of mainly cooling water pump motors, excitation system and AVR cooling fans, space heaters and oil pressure unit etc. The capacity of unit auxiliary transformer shall be selected based on the consideration that it is able to continuously cater to the requirement of all auxiliaries of the respective unit. During the starting and stopping of the units, these unit auxiliaries shall be supplied power from the station auxiliary AC supply system.

*(b) Station Auxiliary AC Supply System*

- (i) The station auxiliary AC supply system shall be designed to provide a high degree of reliability, continuity of service and primarily to supply uninterrupted AC supply to station auxiliaries during normal operation and unit auxiliaries during starting and stopping of the unit and during abnormal events.
  - (ii) The station supply loads for various equipment shall be determined and normal maximum demand shall be calculated at a diversity factor of 1.35. The availability of input supply shall be ensured from the sources independent of station generation. In addition, adequate provision for meeting load of auxiliaries for one unit during starting and/ or during the stopping of the unit shall also be kept and for this purpose the unit auxiliary boards shall be connected to station auxiliary boards through tie breakers.
  - (iii) Two nos. of Station Service Transformers of equal capacity one main and other as standby shall be provided for supplying power to the station service board feeding power to the station auxiliaries. In the event of AC supply failure, the station load shall be supplied by Reliable Standby Power Supply System (RSPSS) of suitable capacity connected to the station service board (SSB). The station service transformers, RSPSS and SSBs shall be located at higher level.
  - (iv) The various auxiliary systems shall incorporate appropriate auto transfer scheme or manual change over to bring in the reserve supply source as required to prevent the loss of unit (s) and to ensure the equipment safety.
- (c) The main or critical switchgear, motor control centres (MCCs), Main Line Distribution Boards (MLDBs) shall be fed by 2x 100 % transformers or feeders and these shall be rated to carry the maximum load expected to be imposed.
  - (d) The electrical protective relays for unit auxiliary and station auxiliary supply system shall be of numerical type with self monitoring and diagnostic features.

**(6) DC supply system**

- (a) The DC supply systems for hydro power stations shall comprise of batteries, battery chargers and DC distribution boards. The standard voltage rating for the DC system shall be 220 V. Suitable converters may be used for other desired voltage levels.
- (b) The battery shall have sufficient capacity to meet unit and station loads in addition to 3 hours of uninterrupted emergency illumination requirement.
- (c) DC system shall comprise of two DC battery sets (both battery sets of full capacity) each with one float cum boost charger.
- (d) The float cum boost battery charger as well as its automatic regulator shall be of static type. It shall have a facility of both auto as well as manual control in both the float and boost modes.
- (e) DC distribution boards shall be designed to supply the various station loads like normal continuous load, emergency lighting load, excitation current for field flashing of generators and indicating lamp loads.
- (f) The DC batteries, battery chargers, and DC distribution board shall be placed at a floor higher than that of machine hall in underground power house and not below the machine hall floor in surface power house.

**(7) Neutral earthing** – The earthing of neutral of various systems shall be as follows:

- (a) General transformer, Station transformer – HV Winding star point : Solidly earthed.
- (b) 11 KV, 6.6kV or 3.3 kV connected : Through a resistance in case of star windings; or  
Through artificial transformer with its secondary loaded with resistor in case of delta connected windings.
- (c) 415 V system : Solidly earthed.
- (d) DC system : Unearthed

**(8) Grounding System**

- (a) The grounding system shall be designed for a life expectancy of at least fifty (50) years, for maximum fault current of the system. MS flats or rods shall generally be used as main ground mat. The touch and step potentials shall be maintained within acceptable limits as per relevant IEEE or IS or IEC standards.
- (b) Grounding and lightning protection for the entire power station and other areas or buildings shall be provided in accordance with relevant IS or IEEE standards.

- (c) Separate distinct grounding systems, if feasible, shall be provided for power house, switchyard and remote structures such as control buildings, communication buildings, spillway gate structures, storage buildings, etc. and other civil or hydraulic structures and inter-connected, if required.
- (d) Special attention shall be made for grounding of high voltage GIS equipment, computer networks and communication equipment as per the manufacturer's recommendations.
- (e) All equipment shall be grounded at two points for reliability.
- (f) Provision at appropriate locations shall be kept for measurement of grounding resistance at regular intervals.

**(9) Illumination**

- (a) i) The illumination shall be provided as per relevant IS. Apart from normal AC illumination system, emergency AC and DC illumination at strategic locations shall also be provided.
- ii) DC illumination shall be provided to enable safe movement of personnel and access to important control points during an emergency.
- (b) i) Energy conservation measures shall be adopted, while designing the lighting system. LED based luminaires, Sodium vapour (high pressure) or other more efficient latest technology lighting fixtures shall be provided for outdoor lighting of areas such as switchyards, spillways and dams, parking areas etc.
- ii) Automatic switching via photo electric cells can be adopted for outdoor lighting to optimize power consumption.
- (c) Metal halide fixtures shall be used for certain indoor areas such as erection bay, generator hall, machine hall, turbine pit and other high bay areas where proper colour rendition is needed and long-life is essential.
- (d) LED lamps shall be used for battery powered emergency lights.

**(10) i) EHV or HV or LV power cables, busducts and control cables–** Cables shall be fire retardant, low smoke, low halogen (FRLSH) type. Directly buried cables shall be essentially armoured type.

- ii) Cables shall be derated for the site ambient and ground temperatures, grouping and soil resistivity as per relevant IS. Wherever feasible or practical, HV or LV busduct shall be used for interconnection.

**(11) Cable trenches and cable racks** - A comprehensive procedure for segregation or separation of cables of different types and voltages shall be adopted for cable installation. For laying of cables in a power house, a broad based system involving cable gallery, tunnels, trenches, cable racks, shafts etc. shall be provided. In outdoor switchyards, a cable trench system shall be provided. The main considerations shall be:

- (a) Segregation and proper spacing shall be maintained;
- (b) Control, auxiliary low voltage (upto 1.1 kV) power and medium voltage (above 1.1 kV and upto 66 kV) power cables shall be laid in separate trays;
- (c) Proper attention shall be given to ventilation and heat dissipation aspects particularly in case of HV cables.

## **(12) Electrical protection system**

- (a) i) Fully graded protection system with requisite speed, sensitivity and selectivity shall be provided for the entire station.
  - ii) Protection relays shall be configured in such a way that digital input points shall not pick up due to stray voltages.
- (b) Protective relays shall be used to detect electrical faults, to activate the alarms and disconnect or shut down the faulted apparatus to provide for safety of personnel, equipment and system.
- (c) Electrical faults shall be detected by the protective relays arranged in overlapping zones of protection.
- (d) i) All generating units shall have standard protection system to protect the units not only from faults within the units and within the Station but also from faults in sub-stations and transmission lines.
  - ii) For the generating units with a rating of more than 100 MW, protection system shall be configured into two independent sets of protection (Group A and B) acting on two independent sets of trip coil fed from independent DC supplies, using separate sets of instrument transformers, and segregated cables of current transformers (CTs) and voltage transformers (VTs).
  - iii) The main protection relays for the generators, motors, transformers and the transmission lines shall generally be of numerical type.
- (e) All relays used shall be suitable for operation with CTs secondary rated for 1 Amp or 5 Amps as per relevant IS or IEC or IEEE standards.
- (f) The protections to be provided for the generating units as a minimum shall be as per Schedule-IV, except for variable speed units which will have specialized protection functions.
- (g) Relevant IS or IEC or IEEE standards shall be applied for protection of generators, transformers and motors.

## **(13) Motors**

- a. The AC Motors shall be squirrel cage or slip ring induction motors suitable for direct on line starting while crane duty motors shall be squirrel cage



type induction motors with variable voltage and variable frequency drive as applicable.

- b. DC Motors shall be shunt wound. Temperature rise for air cooled motors shall be limited to 70<sup>o</sup> C by resistance method for both class B and F insulation.
- c. All motors shall be either totally enclosed fan cooled (TEFC) or totally enclosed tube ventilated (TETV).

#### **(14) Reliable Standby Power Supply System (RSPSS)**

- a. The provision of reliable standby power supply system shall be made to meet the requirement of emergency power supply for essential station services and black starting of the unit considering the starting up of one generating unit at a time during black start condition.
- b. In the event of station service power disruption and for standby supply during grid black-out condition, it shall be ensured that the essential auxiliaries of all the units are fed from RSPSS and non-essential loads are automatically tripped.

### **41. Control, Protection and Instrumentation**

#### **(1) General**

The control and instrumentation system provided for the Station shall be consistent with modern power station practices and in compliance with all applicable codes, standards, guidelines and safety requirements.

#### **(2) Control and protection system**

- (a) Unit and station control system shall be microprocessor or computer based distributed digital control system interconnected through fibre optic cables or copper cables (for distances less than 100 meters) having hundred percent redundancy. Each generating unit shall have independent programmable logic controller with requisite redundancies. The control of each unit from the unit control board shall be independent of each other.
- (b) The following control, operation and monitoring points shall be provided for the generating units:
  - (i) Manual control of individual equipment from control cubicle/control boxes located near the equipment;
  - (ii) Manual and automatic control from unit control board (UCB) located near the unit at machine hall;
  - (iii) Automatic operation from station control centre located in the power house control room;

- (iv) Provision shall be made for automatic operation of plant from remote despatch Centre. It shall be compatible with the station control Centre and shall ensure transfer of data or communication signals.
- (c) The control system shall be divided in the following groups with independent controls:
  - (i) Generating unit controls;
  - (ii) Common controls (for control of common auxiliaries):
  - (iii) Switchyard controls;
  - (iv) Dam gate controls (wherever applicable).

Controls in (i) to (iv) can be suitably merged on case-to-case basis depending upon the extent of control required and the space availability.

The above groups shall be interconnected and also controlled from the control room through computerized control system (CCS). The type of interconnection with remote equipment shall be through a reliable communication mode.

- (d) The following modes of unit start and stop controls shall be provided:
  - (i) Automatic start and stop;
  - (ii) Auto-inactive;
  - (iii) Step by step starting
- (e) As a backup to the microprocessor based controls, a relay based back up shutdown may also be provided for parallel shutdown in case of emergency or protection master trip relay operation.
- (f) A centralized control centre for the control of complete power station shall be installed in power house control room. Computer based human machine interface (HMI) shall be installed with operator control stations having video display units, key board, printers, etc. for the operation of power station. For complete overview of complete station, a passive mimic board of interconnected large video screen (LVS) shall be provided in the control room.
- (g) The emergency stop push button for each unit for unit shut down shall be provided in the control room. The emergency push button shall be hard wired from unit control board.
- (h) An automatic synchronizer with double channel design having frequency and voltage matching including one set of synchronizing equipment for manual synchronizing shall be provided in each UCB. A common manual synchronizing set shall be provided for smaller sets.
- (i) Provisions for the historical storage/long term storage and retrieval of data shall be made.

- (j) The computerized control system shall be compatible as per relevant IS or IEC standards for communication with protection panel, Load Despatch Centre and other PLCs.
- (k) Independent and reliable 230 V AC UPS with 30 minutes backup with requisite redundancy shall be provided for the computerized control system equipment location in control room and DC power supply system shall be provided with minimum of 2 hours battery backup for controllers, input and output cards, control network etc.

**(3) Instrumentation**

- (a) Instruments such as transmitters, RTDs or other types of sensors, gauges, flow elements, transducers etc., shall be provided for comprehensive monitoring of various parameters.
- (b) Microprocessor based vibration monitoring and analysis system shall be provided for crucial rotating equipment.

**42. Provisions Required for Protection of Power House against Flooding**

Following provisions shall be made for protection of Power House against flooding:

- (1) Suitable number of submersible pumps with provision for automatic starting by means of level switches shall be provided at main inlet valve (MIV) floor, in addition to drainage and dewatering pumps as per Regulation 36(3).
- (2) The control panels for dewatering and drainage pumps shall be located at a floor higher than that of turbine floor.
- (3) Suitable float switches shall be provided in power house building to give closing signal to the MIV in the event of inundation of power house due to any reason including penstock rupture or leakage in penstock or for some other reasons.
- (4) The station service transformers and station service boards shall be located at higher level.
- (5) The excitation cubicles, unit control panels, unit protection panels etc. shall be located in the machine hall to the extent possible.
- (6) The DC batteries, battery chargers and DC distribution boards shall be placed at a floor higher than that of machine hall.
- (7) Provision of individual hoisting mechanism for draft tube gates of each unit may be considered for quick closing. The draft tube gates shall be capable of closing under unbalanced condition of water pressure.
- (8) Elevation of pipe for central air admission shall always be above maximum flood level. Central admission system shall be provided for air in runner area of Francis turbines.
- (9) During Construction, the storage of Electro-mechanical equipment shall be made at elevation higher than Flood level.

- (10) During construction, appropriate measures shall be taken to avoid flooding of Power house from Penstock, Tail race or other construction adits.
- (11) As far as possible, the switchyard shall be constructed above the maximum flood level and wherever required, flood protection walls shall also be provided. The switchyard shall be designed to withstand earthquake as per relevant IS.
- (12) There should be regular maintenance (including mock drill of opening and closing) of Penstock Protection Valve (PPV) and the intake gates at regular intervals to ensure they are in proper working conditions so as to prevent flooding.
- (13) Sufficient measures should be taken to prevent ingress of water inside power plant in case of flood like conditions. This may include provision of alternate channels for guiding flood water into river bypassing the power plant.

## Chapter IV

### PART-A

#### SUBSTATIONS AND SWITCHYARDS (66 kV AND ABOVE)

#### 43. General

- (1) The minimum rated short time withstand current of the equipment in substation/ switchyard of following voltage level shall be as per Table 6 below.

**Table 6**

| Voltage level    | Rated short time withstand current /rated breaking current |
|------------------|--|
| 66 kV            | 31.5 kA (for 1 sec.)                                       |
| 110 kV or 132 kV | 40 kA (for 1 sec.)   |
| 220 kV or 230 kV | 50 kA (for 1 sec.)   |
| 400 kV           | 63 kA (for 1 sec.)   |
| 765 kV           | 50 kA (for 1 sec.)   |

- (2) The minimum rated breaking current capability of circuit breaker to be installed at different voltage levels shall be considered as given in above Table 6.
- (3) If the fault level at a sub-station exceeds or is likely to exceed the permissible fault level with the addition of more generators and termination of new transmission lines, adequate measures to limit the fault level like sectionalization/ splitting of the sub-station bus or installation of series reactors

on the line/ bus or installation of Fault Current Limiter (FCL) on line/bus/transformer/ reactor at the respective sub-stations shall be resorted to. Appropriate measures shall be taken to address the impact of the addition of the series reactors or FCL on existing system based on power system studies/dynamic simulations.

- (4) The transformation capacity of any single sub-station for meeting loads at different voltage levels shall not exceed the values indicated in Table 7 below.

**Table 7**

| <b>Substation level</b> | <b>Transformation Capacity</b> |
|-------------------------|--------------------------------|
| 1150 kV                 | 12000 MVA                      |
| 765 kV                  | 9000 MVA                       |
| 400 kV                  | 2000 MVA                       |
| 220 kV/ 230 kV          | 650 MVA                        |
| 110 kV/ 132 kV          | 250 MVA                        |
| 66 kV                   | 100 MVA                        |

Provided, that higher transformation capacity can be adopted for switchyard associated with generating station and stations linked to pooling stations of solar park(s) and wind park(s) developer (s) ensuring that fault level at the switchyard/substation station does not exceed the limits specified in Table-6.

- (5) The sub-station or switchyard shall be designed and constructed to give a life of not less than 35 years.
- (6) The sub-station or switchyard shall have IS/IEC-61850 based Substation Automation System (SAS)/Supervisory Control and Data Acquisition (SCADA) system and Energy Management System and SAS/ SCADA Gateway shall be capable of communicating with Load Dispatch Centre, backup Load Dispatch Centre and Central Control Centre.

#### **44. Design Considerations for Sub-stations and Switchyards**

- (1) The sub-station or switchyard shall be air-insulated sub-station (AIS) or gas insulated sub-station (GIS) or hybrid substation or combination thereof. The factors to be taken into account for designing sub-stations shall be as under:
- (a) The substation or switchyard shall be constructed above the highest flood level and wherever required, flood protection walls shall also be provided.
  - (b) The substation shall be designed for seismic requirement of the site as per relevant IS.

- (c) Land area required shall be considered based on the present requirement and the planned future expansion.
- (d) The shunt capacitors, shunt reactors (bus reactors / switched or non-switched type line reactors), Controlled Shunt Reactors, Static VAR Compensators, Static Compensators, Static condenser, Fixed Series Capacitor, Thyristor Controlled Series Capacitor or other Flexible AC Transmission System devices are the power compensating devices, which shall be based on power system studies.
- (e) The selection of switching schemes shall be based upon requirements for operational flexibility, system security, reliability, availability, criticality of load, maintainability and cost.
- (f) For new substation, in any particular diameter of one and half breaker switching scheme, two transformers or two reactors or a double circuit line shall not be connected.

(2) Air insulated sub-stations (AIS)

- (a) The switching schemes as per Table 8 shall be adopted at different voltage levels in AIS.

**Table 8**

| <b>Voltage level</b>        | <b>Switching Scheme</b>   |
|-----------------------------|---|
| 66 kV or 110 kV or 132kV    | Main and transfer bus scheme or Double bus scheme (with or without breaker bypass arrangement)        |
| 220 kV or 230 kV            | Double main and transfer bus scheme or Double bus scheme (with or without breaker bypass arrangement) |
| 400 kV or 765 kV or 1150 kV | One and half breaker scheme   |

- (b) For 220 kV / 230 kV system with Double Main & Transfer bus scheme or Double bus scheme, bus sectionaliser shall be provided if no. of bays is more than eight (8) excluding bus coupler and bus transfer bays.
- (c) In case of AIS, for bus-bars tubular aluminium pipe or flexible stranded conductor shall be considered taking into account the power flow requirements, corona effect and ambient conditions.
- (d) Outdoor air insulated sub-station or switchyard shall be shielded against direct lightning stroke by provision of overhead shield wire or earthwire or spikes (masts) or a combination thereof.

(3) Gas insulated sub- stations (GIS)

- (a) Gas insulated sub- station (GIS) shall be constructed in seismic prone areas, coastal areas, high altitude areas, very heavily polluted areas and for locations where space is major constraint.
- (b) The switching schemes as per Table 9 shall be adopted at different voltage levels for outdoor, indoor or underground Gas Insulated Sub- station (GIS)

**Table 9**

| <b>Voltage level</b>      | <b>Switching Scheme</b>                           |
|---------------------------|---|
| 66 kV or 110 kV or 132 kV | Main and transfer bus scheme or Double bus scheme |
| 220kV or 230kV            | Double bus scheme                                 |
| 400 kV or 765kV or 1150kV | One and half breaker scheme                       |

- (c) For 220kV / 230kV system with Double bus scheme, bus sectionaliser shall be provided if no. of bays (line, transformer and reactor bays) is more than eight (8) excluding bus coupler and bus transfer bays.
- (d) GIS enclosure shall be non-magnetic type and for 400kV and higher voltage levels, it shall be isolated phase type.
- (e) The arrangement of gas sections or compartments shall be such as to facilitate future extension on either end without any drilling, cutting or welding on existing equipment from any manufacturer and without the necessity of moving or dislocating the existing switchgear bays.
- (f) The layout of Gas Insulated Bus Ducts shall be for easy accessibility & maintenance and the length of busbars, bus ducts, isolator sections shall be optimized considering effects of fast transient voltage due to isolator operations.
- (g) A crane of suitable capacity shall be installed in GIS building for movement of single largest module during installation and subsequent maintenance.

(4) Hybrid sub-station-

- (a) The bus-bars shall be air insulated type and switchgear shall have some or all functional units enclosed in SF<sub>6</sub> gas insulated housing.
- (b) The switching schemes as per Table 9 shall be adopted at different voltage levels.

(5) The Air Insulated/Gas Insulated Substation with complete digitalization shall have (a) digitalization at process level by introducing process bus architecture

& merging unit for conventional/non-conventional Instrument Transformers, (b) digitalization at station level with Ethernet based communication on IEC-61850 protocol, (c) fibre optic cable links, (d) interface between process level & station level through Intelligent Electronic Devices at bay level and (e) security against cyber attack.

(6) Mobile Substations:

- (a) Wherever required, the vehicle mounted mobile substation comprising of trailer, incoming and outgoing HV and LV gas insulated/hybrid switchgears, power transformer, and associated connectors etc. shall be considered for putting into immediate service to resume power supply in short time in case of emergency or disaster.
- (b) The mobile substation shall comply with provisions of CEA Regulations and BIS Codes.

(7) Grounding:

- (a) The grounding system shall be designed for expected life of the substation maintaining the touch and step potential within acceptable limits throughout the life.
- (b) Special consideration shall be given for GIS earthing design to handle high frequency transients.
- (c) If earth enhancement compound / material is considered for effective grounding in high soil resistivity area, the same shall be environmental friendly.
- (d) Condition assessment of earthing mat, earthing pits, earth rod, surface layer material, and associated connections shall be carried out periodically to ensure effectiveness of grounding system and necessary steps shall be taken to mitigate the deficiency, if any.
- (e) To ensure safety, the step and touch potential measurement within substation / switchyard shall be carried out as per IEEE 80 for new installations and measurement shall be repeated for old installation at regular interval and requisite measures shall be taken in case measured values exceed the safe limit.

**45. System design parameters**

- (1) The system design parameters of sub-station and switchyard equipment, except transformer and reactor, for installations at altitude upto 1000 m above Mean Sea Level shall be as given below in Table 10.

**Table 10**



(2) The insulation level for the transformer and reactor windings and bushings shall

| <b>Nominal system Voltage</b>   | <b>66 kV</b> | <b>110 kV</b> | <b>132 kV</b>         | <b>220kV/ 230 kV</b>    | <b>400 kV</b>            | <b>765 kV</b>            | <b>1150 kV</b>           |
|---|--------------|---------------|-----------------------|-------------------------|--------------------------|--------------------------|--------------------------|
| <b>Parameters</b>   |              |               |                       |                         |                          |                          |                          |
| Highest system voltage (kV)   | 72.5         | 123           | 145                   | 245                     | 420                      | 800                      | 1200                     |
| Rated frequency   | 50Hz         |               |                       |                         |                          |                          |                          |
| No. of phases   | 3            |               |                       |                         |                          |                          |                          |
| <b>Rated insulation level</b>   |              |               |                       |                         |                          |                          |                          |
| (i) Minimum Lightning impulse withstand voltage (1.2/50 micro sec.) (kV <sub>peak</sub> )                                 | 325          | 550           | 650                   | 1050                    | 1425                     | 2100                     | 2400                     |
| (ii) Minimum Switching impulse withstand voltage (250/ 2500 micro sec.) dry and wet (kV <sub>peak</sub> )(phase to earth) | NA           | NA            | NA                    | NA                      | 1050                     | 1550<br>(1425 for GIS)   | 1800                     |
| (iii) Minimum One minute power frequency withstand voltage dry (kV <sub>rms</sub> )                                       | 140          | 230           | 275                   | 460                     | 630<br>(650 for GIS)     | 830<br>(960 for GIS)     | 1200                     |
| Minimum corona extinction voltage (kV <sub>rms</sub> phase to earth)  | NA           | NA            | NA                    | NA                      | 320                      | 508                      | 762                      |
| Maximum Radio Interference Voltage for any frequency between 0.5 MHZ to 2.0 MHZ in all positions (micro                   | NA           | NA            | 500<br>(at 92 kV rms) | 1000<br>(at 156 kV rms) | 100<br>0 (at 266 kV rms) | 250<br>0 (at 508 kV rms) | 250<br>0 (at 762 kV rms) |

|                 |         |                     |  |  |  |  |  |
|-----------------|---------|---------------------|--|--|--|--|--|
| volts)          |         |                     |  |  |  |  |  |
| System earthing | neutral | Effectively earthed |  |  |  |  |  |

be as per Table 11 below.

**Table 11**

| Highest voltage for equipment | Windings   |  |   | Bushings  |  |   |
|-------------------------------|--|--|---|---|--|---|
|                               | Rated power frequency withstand voltage ( $kV_{rms}$ ) | Rated switching impulse withstand voltage ( $kV_{peak}$ ) (phase to earth) | Rated lightning impulse withstand voltage ( $kV_{peak}$ ) | Rated power frequency withstand voltage ( $kV_{ms}$ ) | Rated switching impulse withstand voltage ( $kV_{peak}$ ) (phase to earth) | Rated lightning impulse withstand voltage ( $kV_{peak}$ ) |
| 1200 kV                       | NA   | 1800   | 2250  | 1200  | 1950   | 2550  |
| 800 kV                        | NA   | 1550   | 1950  | 970   | 1550   | 2100  |
| 420 kV                        | 570  | 1050   | 1300  | 695   | 1050   | 1425  |
| 245 kV                        | 395  | 750  | 950   | 505   | 850  | 1050  |
| 145 kV                        | 275  | NA   | 650   | 305   | NA   | 650   |
| 123 kV                        | 255  | NA   | 550   | 255   | NA   | 550   |
| 72.5 kV                       | 140  | NA   | 325   | 155   | NA   | 325   |
| 52 kV                         | 95   | NA   | 250   | 105   | NA   | 250   |
| 36 kV                         | 70   | NA   | 170   | 77  | NA   | 170   |
| 24 kV                         | 50   | NA   | 125   | 55  | NA   | 125   |
| 17.5 kV                       | 38   | NA   | 95  | 42  | NA   | 95  |
| 12 kV                         | 28   | NA   | 75  | 30  | NA   | 75  |

- (3) For installations at altitudes higher than 1000 m above Mean Sea Level, altitude correction factor on the applicable parameters such as rated insulation level, clearances and arcing distance for external insulation at the service location

shall be applied as per methodology specified in relevant standards.

#### **46. Salient Technical particulars of major equipments**

##### **(1) Power Transformers**

- (a) Power transformer shall be designed, manufactured, tested and commissioned as per CEA's "Standard Specifications and Technical Parameters for Transformers and reactors (66kV and above)".
- (b) At existing sub-stations, the impedance, vector groups, OLTC connection and range etc. of a new transformer shall be matched with that of the existing transformer(s), if parallel operation is desired.
- (c) In case single phase transformers are provided, minimum one single phase transformer of each rating shall be provided as spare for the entire substation or switchyard
- (d) Dynamic short circuit withstand test shall be conducted on one unit of each type and rating of transformers, to validate the design and quality, unless such test has been successfully conducted as per IS 2026 part-5 within last 10 (ten) years on transformer of similar design. Criteria for similar design shall be as per Annexure-J of CEA's "Standard Specifications and Technical Parameters for Transformers and Reactors (66kV and above)".
- (e) The separation walls or fire barrier walls shall be provided between the transformers / reactors or between transformer / reactor & nearby building as per Central Electricity Authority (Measures relating to Safety and Electric Supply) Regulations.
- (f) Soak Pit and Oil collecting pit:
  - (i) An oil soak pit shall be designed & provided below each oil filled transformer / reactor to accommodate at least 150% of total quantity of oil contained in the transformer / reactor with minimum 300 mm thick layer of gravels / pebbles of approximately 40 mm size (spread over a steel iron grating / trans rack) providing free space below the grating.
  - (ii) Alternatively, an oil soak pit shall be provided below each transformer or reactor, to accommodate 1/3rd of total quantity of oil contained in the transformer / reactor with minimum 300 mm thick layer of gravels/ pebbles of approximately 40 mm size (spread over a steel iron grating/ trans rack) providing free space below the grating provided a common remote oil collecting pit of capacity at least equal to oil quantity in the largest size transformer or reactor is provided for a group of transformers or reactors and bottom of the soak pit below the transformer or reactor shall be connected to the common remote oil collecting pit with drain pipe of minimum 150 mm diameter with a slope not less than 1/96 for fast draining of oil or water through gravity from soak pit to the common remote oil collecting pit.

- (iii) Every soak pit below a transformer or reactor shall be designed to contain oil dropping from any part of the transformer or reactor.
- (iv) The common remote oil collecting pit and soak pit (when remote oil collecting pit is not provided) shall be provided with automatic pumping facility, to always keep the pit empty and available for an emergency.
- (g) The disposal of transformer oil shall be carried out in an environmental friendly manner.

## (2) Shunt Reactor and Neutral Grounding Reactor (NGR)

- (a) Shunt Reactor and NGR shall be designed, manufactured, tested and commissioned as per CEA's "Standard Specifications and Technical Parameters for Transformers and Reactors (66kV and above).
- (b) Wherever required, the neutral of the line shunt reactors shall be grounded through adequately rated Neutral Grounding Reactors (NGR) to facilitate single phase auto-reclosure.
- (c) The Neutral Grounding Reactor shall be provided with bypass arrangement through a breaker so that the line reactor can be used as Bus reactor as and when required.
- (d) The Neutral Grounding Reactor used for 765 kV & 400 kV line shunt reactors, shall be protected by means of 145 kV surge arresters of suitable rating.
- (e) The Neutral Grounding Reactor used with 220 kV & 132 kV line shunt reactors, shall be protected by means of 36 kV surge arresters of suitable rating.
- (f) The neutral of bus reactor shall be solidly grounded.
- (g) In case single phase shunt reactors are provided, then minimum one single phase unit of each rating shall be provided as spare for entire substation or switchyard.
- (h) Soak pit and oil collecting pit as per Regulation 46(1)(f) for oil filled reactor and NGR shall be provided.

## (3) Shunt Capacitors

- (a) Capacitor banks shall not be provided at voltages higher than 132 kV.
- (b) The redundancy in the number of Capacitor units shall be provided to avoid reduction in reactive compensation due to failure of the Capacitor units

## (4) Circuit Breaker

- (a) The circuit Breaker shall be of class M2 with regard to mechanical endurance.

- (b) Circuit Breakers of 220kV and above voltage class shall be suitable for single phase and three phase auto-reclosing and Circuit Breakers of 132kV and below voltage class shall be suitable for three-phase auto-reclosing. Provided that, wherever frequent line to ground faults are encountered on 132 kV lines, Circuit breakers of 132kV class shall be suitable for single phase auto-reclosing.
- (c) Each circuit breaker shall be provided with 2 nos. of trip coils fed through two separate DC supply feeders for greater reliability.
- (d) The circuit breaker shall have the provision for local manual trip, which shall be at a position easily accessible to the operating person.
- (e) Maximum Rated break time for circuit breakers of different voltage classes shall be as given in Table 12 below:

**Table 12**

| <b>Voltage Class</b> | <b>Rated break time</b> |
|----------------------|-------------------------|
| 1150 kV              | 40 ms                   |
| 765 kV               | 40 ms                   |
| 400 kV               | 40 ms                   |
| 220 kV/ 230 kV       | 60 ms                   |
| 132 kV/ 110 kV       | 60 ms                   |
| 66 kV                | 100 ms                  |

- (f) The circuit breakers of 400 kV and above voltage class shall be provided with Pre insertion resistors (PIR) or Controlled Switching Devices (CSD) for controlling switching over voltage for lines of length more than 200 km.
- (g) Controlled Switching Devices shall be used for minimizing switching transients & inrush currents in transformers and reactors of 400kV and above voltage class. Provided that, this requirement is not applicable for generator transformer.
- (h) Due attention shall be given to the operating time and mechanical scatter of Circuit Breakers and grid condition at the point of interconnection while going for use of Controlled Switching Devices.
- (i) The Controlled Switching Device shall come into picture only during energization or de-energization of associated Circuit Breaker and shall remain bypassed otherwise.

**(5) Disconnecter and Earthing Switch**

- (a) Earthing switches shall be provided at appropriate locations to facilitate earthing of outgoing transmission lines to enable maintenance.

- (b) The main blades and earth blades shall be interlocked with both electrical and mechanical means, which shall be fail-safe.
- (c) The disconnectors shall be of M2 class and suitable for Bus Transfer Current Switching duty having provision for remote and local operation.
- (d) Earthing switches used in lines for 110 kV and higher voltages shall be suitable for induced current switching duty of Class B
- (e) Earthing switches shall be suitable for local electrical & manual operation and only local operation is recommended for earth switches
- (f) In case of GIS installations, high speed earthing switches shall be provided for grounding purpose at overhead line terminations and cable terminations and shall have rated fault making capability.

#### (6) Current Transformer

- (a) The rated currents and ratio, the number of secondary cores, accuracy class, burden, secondary winding resistance, knee point voltage, and excitation current shall be in accordance with the requirements of the protection and metering system.
- (b) The rated burden of cores shall be closer to the maximum burden requirement of metering & protection system for better sensitivity and accuracy and shall not exceed 20 VA.
- (c) Instrument Security factor (ISF) shall be less than 5 for CTs upto 400 kV voltage class and less than 10 for CTs of 765 kV & 1150 kV voltage class.
- (d) The accuracy class for metering core shall be equal to or better than the accuracy class of the meter specified in the Central Electricity Authority (Installation and Operation of Meters) Regulations.
- (e) In case of digital substations, Non-Conventional Current Transformers or conventional Current Transformers with merging units that are interfaced with the process bus and station bus architecture shall be used.

#### (7) Voltage Transformer

- (a) The number of secondary cores, accuracy class and burden shall be in accordance with the requirements of the protection and metering system.
- (b) The rated burden of VT cores shall be closer to the maximum burden requirement of metering & protection system for better sensitivity & accuracy and it shall not exceed 50VA.
- (c) The accuracy class for metering core shall be equal to or better than the accuracy class of the meter specified in the Central Electricity Authority (Installation and Operation of Meters) Regulations.
- (d) Wherever Power Line Carrier Communication is provided, capacitor type voltage transformers (CVT) complying with relevant standards shall be used

as the same are suitable for carrier coupling and the capacitance of CVT shall be decided depending on Power Line Carrier Communication requirements.

- (e) In case of digital substations, Non-Conventional Voltage Transformers or conventional Voltage Transformers with merging units that are interfaced with the process bus and station bus architecture shall be used.
- (f) In case of GIS installations, SF<sub>6</sub> filled voltage transformers shall be electromagnetic type.

#### (8) Surge Arrester

- (a) Station class, heavy duty, gapless metal oxide (ZnO) type surge arresters shall comply to relevant standards.
- (b) The rated voltage, continuous operating voltage (COV), energy handling capability, nominal discharge current and other characteristics of a surge arrester shall be chosen in accordance with power system requirements.
- (c) Surge arresters shall be provided at locations decided in accordance with insulation coordination studies.
- (d) These shall be fitted with pressure relief devices and diverting ports suitable for preventing shattering of porcelain housing providing path for the flow of rated currents in the event of failure of surge arrester.
- (e) A leakage current monitor with surge counter shall be provided with each surge arrester.

#### (9) Line Trap

- (a) Line trap complying with the relevant IS/IEC standards shall be used in lines with Power Line Carrier Communication (PLCC) system.
- (b) Line trap shall consist of a main coil in the form of an inductor, a tuning device and a protective device and in conjunction with a coupling capacitor/ CVT, it shall form a parallel resonant circuit.
- (c) The tuning device shall be so arranged as to permit replacement without removing the line trap.
- (d) The tuning as well as protective device shall be so designed that neither significant alteration in the line trap blocking requirements or protective function nor physical damage shall result from either temperature rise or the magnetic field of the main coil at rated continuous current or rated short time current.

#### (10) Insulators

- (a) Porcelain, Glass or composite silicone rubber insulators having life not less than 35 years shall be used.

- (b) The minimum specific creepage distances of insulators shall be as per Table 13 below:

**Table 13**

| <b>Pollution level</b>   | <b>Specific Creepage distance</b>                                   |
|--|---|
| Very light   | 20 mm/kV (corresponding to the line to line highest system voltage) |
| Light and medium   | 25 mm/kV (corresponding to the line to line highest system voltage) |
| Heavy & very heavy pollution areas and areas upto 50 km from sea shore | 31 mm/kV (corresponding to the line to line highest system voltage) |

- (11) Insulation performance enhancement:

In heavy and very heavy polluted areas and coastal areas, the performance of existing insulation of substation equipment housing or insulators (porcelain/ glass insulators) shall be enhanced by using Room Temperature Vulcanized (RTV) silicone rubber coating or silicone jacket creepage extender and the silicone content in these shall be minimum 30%.

- (12) Phase Shift Transformers and Synchronous Condenser:

The rating, phase shift angle & location of Phase Shift Transformers shall be decided based on system studies to control real power flow in transmission lines and suitable provisions shall be made for bypassing of PST. The rating and location of Synchronous Condenser shall be decided based on system studies for dynamic reactive compensation and to improve system resilience.

#### **47. Sub- station and switchyard support facilities**

- (1) AC & DC Supply

- (a) AC & DC supplies shall be provided as per requirements given in Central Electricity Authority (Technical Standards for Connectivity to the Grid) Regulations and for computation of capacity of battery for DC supply in attended sub- station or switchyard, in general, the minimum durations assumed shall be as per Table 14 below.

**Table 14**

|                            |         |
|----------------------------|---------|
| Steady and continuous load | 3 hours |
| Emergency lighting loads   | 1 hour  |

- (b) AC and DC supply system shall be so designed as to meet the requirement



- of present as well as planned future bays of the sub- station.
- (c) DC system shall comprise of two sets of DC battery each with one float cum boost charger.
  - (d) The voltage rating for the DC system for control & protection for 66 kV and 132 kV substations shall be 110V or 220V DC and for 220 kV and above substations it shall be 220 V DC.

(2) Fire Detection, Alarm and Protection System for Sub- station and Switchyard:

- (a) A comprehensive fire detection, alarm as well as fire protection system shall be installed in conformity with relevant IS. In addition, all buildings shall conform to National Building Code.
- (b) All buildings inside the substation or switchyard such as control room building, GIS hall, relay room etc., shall be provided with fire detection and alarm system based on smoke detectors and/or heat detectors. The fire alarm system shall conform to relevant IS or /IEC standards.
- (c) Water hydrant system shall be provided for the following areas in the substations and switchyards:
  - A. Reliable Standby Power Supply system area
  - B. Auxiliary power supply system area
  - C. Stores
  - D. Fire fighting pump house
  - E. Transformers or reactors
- (d) All transformer(s) of 10MVA or reactors of 10 MVAR and above rating shall be provided with High Velocity Water Spray System as per IS 15325 or High Pressure Water Mist System as per NFPA 750 or compressed air-foam system as per NFPA.
- (e) In case of a sub-station or a switching station with apparatus having more than 2000 litres of oil is installed, whether indoor or outdoors, the separation wall or fire barrier walls of four hours fire withstand rating as per IS:1646 shall be provided between the apparatus-
  - (i) where there is a single phase transformer banks in the switch-yards of generating stations and sub-stations;
  - (ii) on the consumer premises;
  - (iii) where adequate clearance between the units as per IS:1646 for O-class oil or as per IS:1180 for K-class oil is not available.
- (f) Portable fire extinguishers shall be provided in the control room building, relay room, GIS hall, fire fighting pump house, stores and Reliable Standby Power Supply System area etc.

- (g) In case of switchyard associated with generating stations, water supply system can be extended from the fire water pump house provided for the generating station.

### (3) Lighting

- (a) Adequate indoor and outdoor lighting including street lighting shall be provided for the sub- station and switchyard.
- (b) Adequate normal and emergency AC and DC lighting shall also be provided in the control room and other identified locations of the sub- station or switchyard.
- (c) Energy conservation measures and energy efficient lighting devices shall be adopted, while designing the lighting system.
- (d) Average illumination levels shall be maintained as per relevant standard.

### (4) Control Room and Kiosk

- (a) Sub-station or switchyard control room shall be provided to house the control and relay panels, Substation Automation System/ Supervisory Control & Data Acquisition System, Power Line Carrier Communication equipment, Optical Line Terminal Equipment, telemetry equipment and recording equipment, AC and DC distribution boards, DC batteries etc.
- (b) In case of substation or switchyard with Substation Automation System, Bay Control Units, Intelligent Electronic Devices (IEDs) or protection relays shall be placed in kiosks located in the outdoor yard .
- (c) Air conditioning with humidity control feature shall be provided in the control room as a functional requirement depending upon site environmental condition.

### (5) Power and Control Cables

- (a) Cables shall be Flame Retardant Low Smoke and Halogen (FR-LSH) type as per relevant IS/ IEC.
- (b) For laying of cables a broad based system involving cable galleries, trenches, cable racks, shafts, cable sealing system etc. shall be provided.
- (c) In outdoor switchyards, a cable trench system shall be provided and a comprehensive philosophy of segregation and proper spacing between cables shall be maintained.
- (d) Power cables and control cables shall be laid on separate tiers.
- (e) The laying of different voltage grade cables shall be on different tiers according to the voltage grade of the cables with higher voltage grade cables in topmost tier and control cables in bottommost tier.

(6) Oil Evacuating, Filtering, Testing and Filling Apparatus

- (a) To monitor the quality of the oil for satisfactory performance of transformers and shunt reactors, and for periodical maintenance, necessary oil evacuating, filtering, testing and filling apparatus shall be provided at a sub-station or switchyard or for a cluster of sub-stations and switchyards.
- (b) Oil tanks of adequate capacities for storage of pure and impure transformer oil shall be provided.

(7) SF<sub>6</sub> Filling, Evacuation, Filtering, Drying & Recycling Plant:

SF<sub>6</sub> filling, evacuation, filtering, drying and recycling plant with adequate storage capacity shall be provided at a sub-station or switchyard or for a cluster of sub-stations and switchyards along with trolley for filling or evacuation of SF<sub>6</sub> circuit breaker or gas insulated switchgear (in case of GIS installation) and to monitor the purity, moisture content, decomposition product etc. of SF<sub>6</sub> gas.

#### **48. Protection and control**

(1) Protective Relaying System

- (a) Selective, sensitive, fast, graded and reliable protection system shall be provided for transmission lines, transformers, reactors, and bus bars so as to automatically isolate the faulty element minimizing the damage in the event of fault or abnormal condition.
- (b) All main protection relays shall be of numerical type and communication protocol shall be as per IS/IEC-61850.

(2) Grouping of Protection

- (a) The protection circuits and relays shall be electrically and physically segregated into two groups each being independent and capable of providing uninterrupted protection even in the event of one of the protection group fails or taken out for maintenance.
- (b) Provided that, interconnection between these two groups shall not generally be attempted. However, such interconnection shall be kept to the bare minimum, if found absolutely necessary,

(3) The protections required in respect of transmission lines, transformers, reactors and bus bars is indicated in Schedule- V.

(4) Disturbance Recorders, Event Loggers and Time Synchronization Equipment-

- (a) Each line or transformer or reactor or any other bay shall be provided with facility for disturbance recording, event logging, distance to fault locator (for

line) and Time Synchronizing Equipment (TSE).

- (b) In addition to inbuilt disturbance recorder, a common Standalone disturbance recorder shall also be provided for 765 kV and above voltage class substation or switchyard.
- (c) Time Synchronizing Equipment complete with antenna, all cables and processing equipment shall be provided to receive synchronizing pulse through global positioning system (GPS) compatible for synchronization of event logger, disturbance recorder, Phasor Measurement Units (PMU) and Supervisory Control & Data Acquisition System/Substation Automation System.

(5) Optical Ground Wire (OPGW)/Power Line Carrier Communication (PLCC)

- (a) OPGW along with necessary terminal equipment shall be provided on transmission lines of voltage rating of 110kV and above for speech transmission, line protection, and data channels.
- (b) The primary path for tele-protection shall be on point-to-point OPGW and alternative path shall be either on PLCC or predefined physically diversified OPGW paths.
- (c) For 66 kV voltage level transmission lines, OPGW or PLCC with necessary terminal equipment shall be provided.
- (d) The protection system for 400kV and higher voltage transmission line and the line compensating equipment shall have one hundred percent back up communication channels i.e. two channels for tele- protection in addition to one channel for speech plus data for each direction.

Provided that, for 220kV, 132 kV, 110 kV and 66 kV lines, the channel for speech plus data can also be used for tele-protection.

- (e) The generating company and the transmission licensee(s) or transmission licensees at both end of substation / switchyard shall coordinate with each other and ensure the compatibility of OPGW/PLCC equipment at their respective ends.

(6) Phasor Measurement Units (PMU)

- (a) Synchrophasor measurement using PMUs along with fibre optic connectivity, GPS Receiver and communication equipment shall be provided for monitoring the entire interconnected grid on real time basis at substations of 400 kV and above voltage level, switchyard of generating stations at 220 kV & above voltage level, AC side of converter bays of HVDC stations and pooling point of renewable energy generating stations of 50 MW and more.
- (b) PMUs shall comply with IS/IEC 60255-118-1-2018.

- (c) The dispersedly located PMUs shall communicate with Phasor Data Concentrators (PDCs) installed at certain strategic locations at State, Regional and National level.

#### **49. Salient Technical Particulars/ Requirements of High Voltage Direct Current (HVDC) Terminals Stations**

- (1) The provisions given at Regulations 43 through 48 shall also be applicable for the AC equipment installed in the HVDC terminal station to be developed for bulk power transfer over long distances or asynchronous connections (back to back) between areas operating with different frequency regimes.
- (2) The HVDC station shall be designed and constructed to give a life of not less than 35 years.
- (3) The interfacing with the DC line (overhead / cable), existing AC network, Telecommunication network, and Load dispatch center shall be properly planned and designed.
- (4) Technical details of HVDC terminals/ stations for Line Commuted Converter (LCC) based technology and Voltage Source Converter (VSC) based technology are given in Schedule- VI.

#### **50. Condition Monitoring of Equipment, Asset Management and security of Sub- station and Switchyard**

- (1) Diagnostic equipment shall be provided to assess the health of various equipment in substations and switchyards as per Central Electricity Authority (Grid Standards) Regulations.
- (2) Portable type diagnostic equipment shall be provided for one or a cluster of substations or switchyards.
- (3) Facility for Partial Discharge monitoring for 220 kV and above Gas Insulated Substations shall be provided.
- (4) Condition Based Maintenance (CBM)/ Reliability Centered Maintenance (RCM) Practice shall be followed for condition assessment of all substation equipment.
- (5) Health indexing of transformers / reactors, based on various indicators derived through condition based analysis, shall be carried out for taking Run/ Refurbish/ Replacement decision.
- (6) Asset management practices shall be adopted to manage asset information (such as serial/ identification no., make, year of manufacturing/commissioning, reports of factory tests/pre-commissioning tests/tests during O&M, technical and other relevant parameters) & operation performance and plan to optimize asset's depreciation, life cycle, monitoring & maintenance with the objective to maximize the efficiency and utilization of capital intensive assets.
- (7) The provisions for substation security surveillance such as camera based visualization system, and motion sensors etc. along with associated software

shall form part of smart security system or remote monitoring system of un-manned remotely operated substations.

**PART – B**

**SUB- STATIONS (33/11 kV, 33/22kV AND 22/11kV)**

51. System Parameters-

(1) The system shall conform to the design parameters indicated in Table 14 below:

**Table 14**

| <b>Parameter</b>   | <b>33 kV</b> | <b>22 kV</b> | <b>11kV</b> |
|--|--------------|--------------|-------------|
| Nominal system voltage (kV)                                  | 33           | 22           | 11          |
| Highest system voltage (kV)                                  | 36           | 24           | 12          |
| Frequency (Hz)   | 50           | 50           | 50          |
| Lightning impulse withstand voltage (kV <sub>peak</sub> )    | 170          | 125          | 75          |
| Power frequency withstand voltage (dry) (kV <sub>rms</sub> ) | 70           | 50           | 28          |

(2) System earthing shall be as per Central Electricity Authority (Measures relating to Safety and Electricity Supply) Regulations, 2010 as amended from time to time.

52. General Consideration for 33/11 kV, 33/22 kV and 22/11 kV Sub-stations and Switching Stations-

- (1) The sub-station shall be indoor or outdoor or underground type depending upon the site requirement.
- (2) The sub-station shall be either air insulated (AIS) or gas insulated (GIS) or hybrid, as the case may be:  
Provided that in coastal areas substation shall be GIS.
- (3) The 33/ 11 kV or 33/ 22 kV or 22/ 11 kV sub-stations shall have adequate capacity to cater to load growth for at least five (5) years.
- (4) The maximum capacity of 33/ 11 kV or 33/ 22 kV or 22/ 11 kV sub-station shall be 75MVA, 60 MVA and 60MVA respectively.

- (5) To meet N-1 contingency, each 33/ 11 kV or 33/ 22 kV or 22/ 11 kV sub-station shall normally have
  - (a) two or more transformers and
  - (b) two incoming feeders from two different sources.
- (6) In case both (the 33 kV or 22 kV) incoming feeders to the sub-station are from the same source (sub-station), each feeder shall supply independent sections of the 33/ 11 kV or 33/ 22 kV or 22/ 11 kV sub-station, the two sections being isolated from each other by bus sectionalizer or isolators.
- (7) All sub-stations shall have independent circuit breaker control of 33 kV or 22 kV incoming feeders, transformers and 22 kV or 11 kV outgoing feeders.
- (8) All the incoming feeders feeding the sub-stations shall have independent circuit breaker at source end.
- (9) In areas where RoW issues exist, the incoming and outgoing feeders shall be on multi circuit towers to minimize the Right of Way requirement.
- (10) The layout of the sub- station itself shall be such that the fire shall not spread from one to other equipment and areas as far as possible.
- (11) While selecting equipment for the sub-station de-rating due to increase in altitude and for cables due to depth of burial in the ground shall be given due consideration as per the altitude/depth of burial at the site.

**53. Selection of Site-** The selection of the site of the sub-station shall be done on the basis of the following:

- (a) The site shall take into consideration the capacity and location of the feeding grid sub-station, load in the area, spatial load forecast, demographic factors, the existing network configuration, etc. and the economic, and environmental considerations
- (b) The site shall be near the load center;
- (c) The site shall be such that it is convenient for terminating extra high voltage (EHV) or high voltage (HV) lines or cables;
- (d) The site shall not be in a low-lying area to avoid flooding during the rains;
- (e) The site shall be easily approachable in all the seasons;



- (f) The site for air-insulated sub-station shall be away from garbage dumping ground to avoid vulture faults;
- (g) The land shall be reasonably levelled and shall not have any open drain or nallah or road crossing it.

**54. Switching Arrangements-**(1) Switching arrangements shall ensure operational flexibility, system safety and reliability.

(2) Single bus, single bus with bus sectionalizer, main and transfer bus, double bus or mesh arrangement shall be adopted as per requirement.

**55. System Configuration-** The system configuration shall be radial, ring or combination of both as per requirements:

(1) Provided that the radial configuration shall be minimized to improve reliability.

(2) Provided further that in densely loaded city centers, and for essential services and installations, the system shall be of ring configuration.

**56. Power Transformers-**

(1) The transformers shall comply with the relevant IS.

(2) The 33/ 11 kV or 33/ 22 kV or 22/ 11 kV transformers shall have delta star or delta-zigzag winding connection.

(3) At existing sub-stations, the percentage impedance, vector groups, on load tap changer connection and range of the new transformer shall match with that of the existing transformer.

(4) The type and place of installation of transformer shall be as per Central Electricity Authority (Measures relating to Safety and Electricity Supply) Regulations, 2010 as amended from time to time.

(5) Transformers shall withstand, without injurious heating, combined voltage and frequency fluctuations which produce the over fluxing conditions as: 125% for 1 minute, 140% for 5 seconds and 150% for 1 second.

(6) Each transformer shall be provided with gas and oil actuated Buchholz relay fitted with alarm (local and remote) and trip contacts, if applicable.

- (7) (a) A transformer with off-circuit tap changer shall have taps ranging from (+) 5% to (-) 10% in steps of 2.5% each on the higher voltage winding for variation in the voltage.  
(b) The tap changing switch shall be located in such a way that it can be operated from ground level.  
(c) The switch handle will be provided with a locking arrangement along-with tap position indication, for locking the switch.
- (8) (a) On load tap changing (OLTC) device shall be provided with transformers of 3.15 MVA and higher rating for better voltage control by manual and automatic means.  
(b) A transformer with on-load tap changer shall have taps ranging from (+) 5% to (-) 15% in steps of 1.25% each on 33 kV or 22 kV winding for voltage variation.
- (9) All electrical safety requirements, clearances and ventilation shall be as per Central Electricity Authority (Measures relating to Safety and Electricity Supply) Regulations, 2010 as amended from time to time.
- (10) (a) For indoor installation, the room shall be well ventilated for escape of heated air.  
(b) air inlets shall be provided near the floor and outlets near the ceiling.
- (11) A transformer shall be physically checked and tested for its electrical and mechanical performance characteristics as per relevant IS before commissioning.
- (12) Transformer Health Monitoring system shall also be provided for monitoring the health of power transformers.
- (13) A transformer shall be provided with two separate body earthing terminals which in turn shall be connected to two separate earth points, besides neutral earthing terminal.

## **57. Bus-bars-**

- (1) Bus-bars shall be of Rigid type or Strain type.
- (2) Bus-bar shall be able to carry the expected maximum load current continuously without exceeding the temperature rise limit as per relevant IS.

(3) The capacity of a bus-bar shall also be checked for maximum temperature rise of the conductor under short circuit conditions.

(4) The bus-bar connections and insulator supports shall be mechanically strong and bus-bars shall be supported so as to withstand the stresses generated by vibrations and short circuits.

(5) Aluminium or Copper used for bus-bars shall conform to relevant IS.

## **58. Structures-**

(1) Structures shall be provided for:

- (a) Incoming and outgoing gantries and/or cable supports and terminations;
- (b) Circuit breakers, isolators, fuses, insulators, CTs and PTs (potential transformers);
- (c) Bus-bars and insulators.

(2) Switchyard structures shall be made of fabricated steel, reinforced cement concrete (RCC) or pre-stressed concrete (PSC), rail or rolled steel joist (RSJ) depending on technical and economic considerations.

(3) The structures shall be able to withstand tension of conductors and load of the equipment and accessories without guys or stays.

(4) The steel structures shall be hot dip galvanised or painted:

(5) In highly polluted and corrosive atmospheric conditions galvanised structures with paint shall be used.

(6) Adequate muffing above the ground level shall be provided to avoid water accumulation near the structures.

## **59. Insulators-**

(1) The insulators shall comply with relevant IS.

(2) The station design shall be such that number of insulators is minimum but at the same time reliability of supply is ensured.

(3) Suitable means shall be provided to accommodate conductor expansion and contraction and there shall not be any undue stress on any part or equipment due to temperature change.

- (4) The minimum creepage distances for different pollution levels shall be as per Regulation 43.
- (5) The post insulators shall be of pedestal type or Solid Core Station type.
- (6) In the areas where problem of insulator pollution is expected (such as near sea or thermal power station, railway station, industrial area, etc.) special insulators viz. semi conducting glazed porcelain or polymer insulators with higher leakage resistance and creepage distance shall be used to minimize the flashover.
- (7) The special coating like Room Temperature Vulcanized (RTV) coating may also be used on the insulators in polluted areas as per requirement.

**60. Circuit Breakers-**

- (1) Circuit breakers (CBs) shall comply with the relevant IS and shall be SF<sub>6</sub> or vacuum type.
- (2) The rated voltage of the circuit breakers shall be as per highest system voltage.
- (3) Rated short time current rating of 33 kV circuit breakers shall not be less than 25 kA for 1 second and for 22 kV or 11 kV CBs shall not be less than 16 kA for 1 second.
- (4) The operating mechanism of circuit breakers shall be motor operated spring charged type or magnetic actuator type.
- (5) The circuit breaker shall be provided with anti-pumping and trip free features.
- (6) The indoor circuit breakers shall be metal clad, either fixed type or draw out type.
- (7) The rated rupturing capacity of the circuit breaker to be installed at any new sub-station shall be at least 25% higher than the calculated maximum fault level at the bus to take care of the increase in short circuit levels as the system grows.

#### 61. Isolators and Earthing Switches-

- (1) The isolators shall be as per capacity of substation and shall comply with relevant IS.
- (2) The operating mechanism for the isolators and the controlling circuit breaker shall be interlocked so that the isolators cannot be opened unless the corresponding breakers are in open position.
- (3) Earthing switches shall be provided at various locations to facilitate maintenance.
- (4) Main blades and earth blades of earthing switches shall be interlocked, both electrically and mechanically.
- (5) Earthing switches shall be motor operated as well as suitable for manual operation.

#### 62. Control and Relay Panels-

- (1) The control and relay panels shall conform to relevant IS.
- (2) The panel shall be provided with:
  - (a) Numerical over current and earth fault relays conforming to relevant IS.
  - (b) Measuring instruments such as ammeter, voltmeter and energy meter for 33 kV, 22 kV and 11 kV systems.
  - (c) Mimic diagrams.
  - (d) Annunciation, alarms and trip facilities.

#### 63. Surge Arrestor

- (1) Distribution class, heavy duty, gapless metal oxide (ZnO) type surge arresters conforming to relevant IS shall be provided on the buses, high voltage and low voltage sides of all transformers and on the incoming terminations of 33/ 22 kV lines.
- (2) The surge arrester (SA) which responds to over-voltages without any time delay shall be installed for protection of 33 kV, 22 kV

and 11 kV switchgear, transformers, associated equipment and 33 kV, 22 kV and 11kV lines.

(3) Surge arresters shall be single-phase units suitable for outdoor duty.

(4) The rated voltage of surge arresters shall be 30 kV, 22 kV, 9 kV and nominal discharge current rating shall be 10 kA, 7.5kA and 5 kA for use on 33 kV, 22 kV and 11 kV systems respectively.

(5) Surge arresters for transformers shall be mounted as near the transformers as possible and the star point shall be connected to the independent earthing point.

#### 64. Instrument Transformers (Current and Voltage Transformers)

##### (1) **Current transformers (CTs)**

(a) Current transformers shall comply with relevant IS.

(b) The rated current and ratio, the number of secondary cores (protection and/or metering), accuracy class, burden, secondary winding resistance, knee point voltage, instrument security factor and excitation current shall be as per the requirements of the protection and metering system.

(c) Where the distance between the primary equipment and relay panel is large, CT of 1 Amp secondary current shall be used to avoid large VA (volt ampere) burden on the CT.

(d) The CT may be oil filled or resin type for outdoor use and shall normally be cast resin type for indoor use.

(e) The accuracy class for metering core shall be as per the Central Electricity Authority (Installation and Operation of Meters) Regulations, 2006as amended from time to time.

##### (2) **Voltage transformers (VTs)**

(a) Voltage transformers shall conform to relevant IS.

- (b) The number of secondary cores (protection or metering), accuracy class and burden shall be as per the requirements of the protection system.
- (c) Voltage transformers shall be of inductive type or capacitor type.
- (d) The voltage transformers shall be oil filled or cast resin type for outdoor use:  
Provided that the indoor voltage transformers shall be cast resin type.
- (e) Multiple earthing of voltage transformers shall be avoided under any circumstances.
- (f) The accuracy class for metering core shall be as per the Central Electricity Authority (Installation and Operation of Meters) Regulations, 2006 as amended from time to time.

**65. Control Room-**

- (1) Control room shall be provided to house the control and relay panels and all other indoor equipment, and measuring, monitoring and recording system required for control and operation of the sub-station.
- (2) Adequate space shall be provided for the operation and maintenance staff.
- (3) Provision of space for future expansion shall also be kept.

**66. Earthing Arrangement-**

Earthing shall be carried out in accordance with relevant IS and Central Electricity Authority (Measures relating to Safety and Electricity Supply) Regulations, 2010 as amended from time to time.

**67. Reactive Power Compensation-**

- (1) Capacitors, residual voltage transformers and neutral current transformers shall be as per relevant IS.
- (2) Shunt capacitors shall be connected on secondary side of 33/11 kV, 33/22 kV or 22/11kV transformers.
- (3) The capacitors shall be of automatic switched type for sub-stations of 5 MVA and higher capacity.
- (4) Where un-switched (fixed) capacitors are provided, the rating shall be chosen so as to prevent over compensation during off peak periods.

- (5) Each capacitor unit shall be provided with a built-in discharge resistor of adequate rating to discharge the residual voltage as per relevant IS.
- (6) The capacitors shall be fixed firmly to the supporting structure to make them immovable.
- (7) Where the sub-station is feeding loads which have high harmonic levels, suitable harmonic filters shall be installed.
- (8) In cases of sub-stations loaded with highly fluctuating loads like arc furnaces etc., flickers and voltage regulation problems may be overcome by installation of static var compensators (SVCs) or STATCOM.

#### **68. Power and Control Cables**

- (1) Cables shall be as per relevant IS.
- (2) Cable laying shall be done complying with requirements of relevant IS including manufacturer's recommendation.
- (3) The cables shall be segregated by running in separate trenches or on separate racks, with the highest voltage class cables laid at the highest racks or tiers.
- (4) Cables shall not be laid directly on the trench floor.
- (5) The cable trenches shall be properly sloped so as to drain freely any water which may enter.
- (6) Care shall be taken in sub-station design to permit easy entry of cables into switchgear and convenience of handling afterwards.
- (7) Segregation of AC and DC control cables and power cables shall be done.
- (8) Sufficient extra length of cable shall be provided for repair of faults in terminations inside the switchgear.
- (9) The relevant drawings of cable sizes, routes and termination details of control cables in the panels shall be available at work site and shall be preserved for future use and reference in the sub-station.
- (10) All cable ends shall be suitably labelled to facilitate easy identification.



(11) Power Cables:

- (a) Power cables shall be cross linked poly ethylene (XLPE) insulated, poly vinyl chloride (PVC) sheathed type.
- (b) Cables shall be flame retardant low smoke and low halogen type or flame retardant low smoke zero halogen type.
- (c) Cables shall be de-rated for the site's ambient and ground temperature, grouping and soil resistivity as per IS.
- (d) Proper attention shall be given to ventilation or heat dissipation aspects particularly in case of HV cables.

(12) Control Cables:

- (a) The control cables shall be of copper.
- (b) Separate control cables shall be used for each CT and VT.
- (c) Ferrules used on ends of control cables shall match with the details shown in the relevant termination drawings.
- (d) Adequate number of spare cores shall be included in all control cables.

**69. Telecommunication System-** A dedicated and reliable telecommunication system as per Central Electricity Authority (Technical Standards for Communication System in Power System Operations) Regulations, 2020 as amended from time to time

**70. Automation System-** Supervisory control and data acquisition system (SCADA) and data acquisition system (DAS) shall be provided in the sub-stations, associated feeders and distribution transformers for improving the operational flexibility, minimizing restoration time of power supply and preventing overloading of lines and transformers in real time mode.

**71. Sub-station Support Facilities**

(1) **DC supply arrangement-** The battery charger, battery and load shall be connected in parallel and work as a system.

(a) **Battery-**

- i. The 24V, 30V, 48V, 110V, 220V DC batteries shall be stationary lead acid or nickel cadmium or lithium-ion type.
- ii. The capacity and discharge rate of the batteries shall be as per the requirement.
- iii. The batteries shall conform to relevant IS.
- iv. A separate room for Substation Batteries shall be provided with ventilation and exhaust fan for taking out fume gases and provision of remote monitoring of sub-station batteries and exhaust fan shall also be made.

(b) **Battery charger-**

- (a) The battery chargers shall be automatic float cum booster type.
- (b) The battery charger shall be capable of continuous operation at the rated load in float charging mode.
- (c) The charger in boost charging mode shall be capable of boost charging the associated DC battery at the desired rate.

(2) **Auxiliary power supply transformer-** An auxiliary power supply transformer capable of meeting the auxiliary and lighting loads of the sub-station shall be provided..

(3) **Oil and SF<sub>6</sub> evacuating, filtering, testing and filling apparatus-** Oil and SF<sub>6</sub> filling, evacuation, filtering and testing plants with adequate storage facilities along with requisite operation and maintenance (O&M) tools and plants shall be provided for a cluster of sub- stations as per requirement.

**72. Fencing and Approach Arrangement-**

- (1) Fencing or boundary wall shall be provided around the sub- station as per CEA (Measures relating to Safety and Electric Supply) Regulations, 2010 as amended from time to time.
- (2) A metalled approach road to transport the equipment shall be provided leading from the main road.

**73. Lighting System**

In addition to the energy efficient lighting system provided for catering to the normal AC lighting load, emergency lighting operated on the DC

system shall be provided in strategic locations viz. control room, battery room, passages etc.:

Provided that it shall be ensured to provide separate DC battery bank for emergency lighting in the substation and Sub Station's main battery bank used for protection system is not used for emergency lighting to avoid the draining of the main battery bank.

#### 74. Fire Fighting System

- (1) The fire fighting system at Sub stations shall be as per Central Electricity Authority (Measures relating to Safety and Electricity Supply) Regulations, 2010 as amended from time to time.
- (2) Fire extinguisher used in the fire fighting system shall conform to relevant IS.

### PART-C

#### DISTRIBUTION SUB-STATIONS (DSS)

75. **General-** (1) The system shall conform to the design parameters indicated in Table 15 below:

**Table 15**

| Parameter  | 33 kV | 22 kV | 11kV | 0.415 kV |
|--|-------|-------|------|----------|
| Nominal system voltage (kV)                                  | 33    | 22    | 11   | 0.415    |
| Highest system voltage (kV)                                  | 36    | 24    | 12   | 0.450    |
| Frequency (Hz)   | 50    | 50    | 50   | 50       |
| Lightning impulse withstand voltage (kV <sub>peak</sub> )    | 170   | 125   | 75   | -        |
| Power frequency withstand voltage (dry) (kV <sub>rms</sub> ) | 70    | 50    | 28   | 3        |

- (2) System earthing shall be as per Central Electricity Authority (Measures relating to Safety and Electricity Supply) Regulations, 2010 as amended from time to time.
- (3) For consumers supplied at voltage not exceeding 650 V (except mines and oil fields), the nominal r.m.s value of Voltage at the

point of commencement of supply of electricity, shall be as follows :

- (i) Single Phase 230 Volts between phase and neutral
- (ii) Three Phase 400 Volts between phases

Explanation: For the purpose of sub-regulation 74(1A), the expression "point of commencement of supply of electricity" shall mean the point at the outgoing terminal of meter installed at the consumer premises.

- (4) The distribution sub- stations (DSS) shall normally be located near load center.
- (5) The DSS can be installed indoor or outdoor or underground as per site requirement.
- (6) The DSS with dry type transformer can be used for rooftop installation provided that the building is suitable for bearing the load and adequate fencing or isolation arrangement is ensured.
- (7) The DSS can be conventional, package type, completely self protected (CSP) type.
- (8) DSS may be installed vertical type (DT on ground with RMU & LT switches above DT on another platform or vice versa).
- (9) The capacity of DSS shall be as per the load requirement keeping in view the future load growth for at least 5 years.
- (10) In the selection of the equipment for the distribution sub station de-rating due to increase in altitude and for cables due to depth of burial shall be given due consideration as per the altitude or depth of burial at the site.

#### **76. Distribution Transformers-**

- (1) The transformer shall conform to relevant IS and shall be ISI marked.
- (2) The transformer can be oil filled, or dry type depending on requirements and shall be as per the Central Electricity Authority (Measures relating to Safety and Electricity Supply) Regulations 2010.
- (3) The maximum losses for dry transformers shall not be more than the values specified in latest Energy Conservation Building Code (ECBC) of BEE till IS for dry type transformer are published.
- (4) In coastal areas, Distribution Transformer shall be indoor or package type or plinth-mounted.

## **77. Transformer Mounting Structure-**

- (1) The mounting of transformers shall be as per relevant Indian Standards.
- (2) The structures shall be provided with
  - (a) anti-climbing devices and
  - (b) danger board.
- (3) (a) The plinth shall be: i) higher than the surroundings.  
(ii) Made of Concrete/ Metal (properly earthed) or fire resistant fibre glass of adequate strength to withstand the load:
  - (b) the plinth can be pre-fabricated also:
  - (c) the plinth foundation shall be of concrete.
- (4) Plinth mounted distribution sub-stations shall be adequately protected by fencing so as to prevent access to the equipment by unauthorized persons, animals and shall be provided with standard danger boards.

## **78. Surge Arresters-** (1) Surge arrester conforming to relevant IS shall normally be installed on the high voltage side of the transformer connected to overhead lines:

Provided that surge arrester shall also be provided on the low voltage side in areas of high isoceraunic activity.

- (2) Surge arresters of rating 9 kV on 11 kV, 20 kV on 22 kV and 30 kV on 33 kV outdoor type shall be used for diverting the lightning surges to earth.

## **79. LT Distribution Box-** (1) LT distribution box consisting of breaker and fuse cutouts and fittings conforming to relevant IS shall be provided from where distribution feeders shall be taken out.

- (2) The size of the box shall be suitable for accommodating moulded case circuit breaker (MCCB), fuse cutouts, cable connectors, bus-bars etc.

- (3) The distribution box shall be mounted at a height of minimum 1.5 metres for pole mounted distribution transformers while the feeder pillar box can be installed at ground level, with adequate clearance:

Provided that for single phase transformer, the distribution box can also be directly mounted on the body of transformer.

**80. Protection System - The protection system of transformers shall be as per Central Electricity Authority (Measures relating to Safety and Electricity Supply) Regulations, 2010 as amended from time to time.**

**(1) 33/ 0.4 kV DSS and 22/ 0.4 kV DSS**

- (a) Suitable high rupturing capacity cartridge fuse or moulded case circuit breakers (MCCB) or miniature circuit breakers (MCB) or air circuit break switch (ACB) shall be provided on low voltage side.
- (b) The high voltage side of these transformers shall be protected by circuit breakers or drop out fuses.

**(2) 11/ 0.4 kV DSS**

- (a) Suitable high rupturing capacity cartridge fuses or moulded case circuit breakers (MCCB) or miniature circuit breakers (MCB) or air break switch shall be provided on low voltage side for transformers of 100 kVA and above: Provided that the high voltage side of these transformers shall be protected by drop out expulsion type fuses or circuit breakers.
- (b) Horn gap fuse with air break switch shall be provided on high voltage side and switch fuse unit or wire fuse on low voltage side shall be provided for transformers below 100 kVA.

**81. Earthing-** Earthing shall be provided for the DSS complying with relevant Indian Standards and Central Electricity Authority (Measures relating to Safety and Electricity Supply) Regulations 2010 as amended from time to time.

**82. LT Cables-** (1) IS compliant XLPE cables shall be used for connecting LT supply from transformer bushings to the LT circuit breaker in the distribution box and for taking out outgoing feeders from the fuse units to the overhead lines.

(2) The LT cables may be armoured or unarmoured for transformers rated less than 100 kVA and shall be armoured for transformers of 100 kVA and higher ratings.

(3) The cables shall be properly clamped to the support without damaging the insulation.

(4) A loop arrangement shall be made at the connecting end and laying of cables shall be in such a way that rain water does not enter.

**83. Meters-** The installation of meters shall be in conformance to the Central Electricity Authority (Installation and Operation of Meters) Regulations, 2006 as amended from time to time.

**84. Reactive Compensation-**

- (1) Where the power factor is low, reactive compensation shall be provided on the distribution transformers by fixed or automatic switched type capacitors of adequate rating.
- (2) In case of fixed capacitors it shall be ensured that the rating of the capacitors is such as to prevent over compensation during off peak period.
- (3) In cases where loads fluctuate very fast, a suitable dynamic compensation like thyristor switched capacitors maybe considered.
- (4) In loads which are rich in harmonics, suitable harmonics filters or de-tuned filter banks shall be considered.

## **Chapter V**

### **PART-A**

#### **ELECTRIC LINES (66 kV AND ABOVE)**

**85.General**

- (1) The transmission line shall be designed and constructed to give a life of not less than 35 years.
- (2) Overhead transmission lines shall be planned, designed and constructed at least in double circuit configuration.  
  
Provided that for 765 kV lines single circuit configuration can be used with the approval of the National Committee on Transmission.
- (3) Right-of-way (ROW) for transmission lines of different voltage levels (with specific conductor type & configuration, design span and string arrangement) traversing through **normal terrain / route without constraint, forest area, urban area, populated area and approach section near substation shall be as per schedule-VII.**
- (4) For transmission lines in areas where ROW constraint is encountered, appropriate technology options such as use of steel pole structure, narrow based lattice towers, multi-circuit & multi-voltage towers, lattice / steel pole structure with one side stringing, XLPE cable or Gas Insulated Line, compact towers with insulated cross arm, and Voltage Source Converter based HVDC transmission on overhead line or underground cable shall be adopted.

- (5) Steel pole structure, Multi-circuit (more than two circuits) / multi-circuit & multi-voltage towers for overhead lines upto and including 400kV voltage level shall be considered in the urban areas, approach section of substation/ switchyard and as an alternative to no. of parallel lines passing through forest, eco-sensitive zone, wildlife sanctuary for effective use of available corridor.
- (6) Routing of a transmission line shall avoid large habitations, densely populated areas, protected / reserved forest/ National Parks / Wild Life Sanctuaries, the habitant zones of Great Indian Bustard and other protected species, civil / military airfields and aircraft landing approaches.
- (7) The transmission line routing shall be done avoiding any structure / hut / borewell. Necessary safety clearances need to be maintained as per CEA (Measures relating to Safety and Electric Supply) in case of unavoidable circumstances.
- (8) The names of owners of the land falling under RoW of the transmission line shall be recorded after carrying out the check survey at the time of execution.
- (9) The Transmission Service Provider / Transmission licensee shall arrange consents & approvals from Power & Telecommunication Co-ordination Committee (PTCC) and the concerned authorities for environmental & forest, mining, civil aviation, road, river, rail, canal and power line crossings.

## 86. Design and Construction of Transmission Lines

### (1) Electrical Design Parameters of the Transmission Lines

- (a) The design parameters of the transmission lines for . altitude upto 1000 m above mean sea level (MSL) shall be as indicated in Table 17 below:

**Table 17**

| Parameter                        | 66 kV AC | 110 kV AC | 132 kV AC | 220 kV/ 230 kV AC | 400 kV AC | 765 kV AC | ±500 kV HVDC | ±800 kV HVDC | 1150 kV AC |
|----------------------------------|----------|-----------|-----------|-------------------|-----------|-----------|--------------|--------------|------------|
| Nominal voltage (kV)             | 66       | 110       | 132       | 220/<br>230       | 400       | 765       | 500          | 800          | 1150       |
| Highest system voltage (kV)      | 72.5     | 123       | 145       | 245               | 420       | 800       | 525          | 840          | 1200       |
| Rated Insulation Level (minimum) |          |           |           |                   |           |           |              |              |            |
| (i)Lightnin                      | 325      | 550       | 650       | 1050              | 1550      | 2400      | 1800         | 2250         | 2400       |



|  |     |     |     |                         |                         |                         |                                     |                                     |                         |
|--|-----|-----|-----|-------------------------|-------------------------|-------------------------|-------------------------------------|-------------------------------------|-------------------------|
| g impulse withstand voltage (1.2/50 micro sec)(kV <sub>peak</sub> )                      |     |     |     |                         |                         |                         |                                     |                                     |                         |
| (ii)Power frequency withstand voltage under dry condition (kV <sub>rms</sub> )           | 140 | 230 | 275 | 460                     | 680                     | 830                     | NA                                  | NA                                  | 1200                    |
| (iii)Switching surge withstand voltage under wet condition (kV <sub>peak</sub> )         | NA  | NA  | NA  | NA                      | 1050                    | 1550                    | 1000                                | 1850                                | 1800                    |
| Minimum corona extinction voltage under dry condition (kV <sub>rms</sub> phase to earth) | NA  | NA  | NA  | 156                     | 320                     | 508                     | 550                                 | 880                                 | 762                     |
| Maximum radio interference voltage under dry condition (micro volts)                     | NA  | NA  | NA  | 1000<br>(at 156 kV rms) | 1000<br>(at 320 kV rms) | 1000<br>(at 508 kV rms) | 22 kV/cm conductor surface gradient | 22 kV/cm conductor surface gradient | 1000<br>(at 762 kV rms) |

(b) For installations at altitudes higher than 1000 m above Mean Sea Level, altitude correction factor on the applicable parameters such as rated insulation level, clearances and arcing distance for external insulation at the service location shall be applied as per methodology specified in relevant standards.

- (c) The phase conductors of AC transmission lines shall be transposed in approximately three equal parts, wherever the length of the line is more than 100 km.

## (2) Conductor

- (a) Minimum two conductors per phase for 400 kV AC; four conductors per phase for  $\pm$  500 kV HVDC & 765 kV single circuit AC; six conductors per phase for 765 kV Double Circuit AC &  $\pm$  800kV HVDC and eight conductors per phase for 1200 kV AC shall be used to meet the corona and Radio Interference requirement.
- (b) The conductors shall be Aluminum Conductor Steel Reinforced (ACSR) or All Aluminum Alloy Conductor (AAAC) or Aluminium Alloy Conductor Steel Reinforced (AACSR) or High Conductivity Aluminium Alloy stranded conductors or High Performance conductors (HPC) or High Temperature and Low Sag (HTLS) conforming to relevant IS or IEC or other international standards.

## (3) Earthwire

- (a) The earthwire of appropriate size to cater to predicted and design fault currents and lightning shall be used.
- (b) Single earthwire shall be used for transmission lines up to 220 kV and two earthwires shall be used for transmission lines of 400 kV and higher voltage classes.
- (c) The earthwire used in 66 kV voltage class lines shall be OPGW or galvanized stranded steel (GSS) or Aluminium Alloy Conductor Steel Reinforced (AACSR) type.
- (d) The earthwire used in 110 kV and above voltage class lines shall be OPGW.

Provided that in case of 400kV and above voltage class lines, at least one out of two earthwires shall be OPGW and second earthwire shall be either of galvanized stranded steel (GSS) or Aluminium Alloy Conductor Steel Reinforced (AACSR) conductor type.

## (4) Towers

- (a) The towers shall be self-supporting lattice steel structure or steel pole structure or structure with insulated cross arms and shall be fully galvanized.
- (b) All electrical clearances shall be as per relevant standard and Central Electricity Authority (Measures relating to Safety and Electricity Supply) Regulations.
- (c) The pole, towers, and towers with insulated cross-arms shall be designed considering design loading criteria and conditions as per relevant IS.

- (d) Wind Zone considered for wind loading shall be as per wind map given in National Building Code till the relevant IS is revised.
- (e) For design of transmission line structures in areas upto 60 km from sea coast, importance factor for cyclonic region i.e. K4 factor of 1.3 shall be considered to take care of cyclonic wind condition.
- (f) For the transmission lines to be laid within 50 Kms of the border of the two wind zones specified in the Wind Map, towers shall be designed for the higher of the two wind ones.
- (g) Reliability level as per Table-18 shall be considered for design of towers and steel pole structures of following transmission lines:

**Table-18**

|  |  |
|--|--|
| 66 kV to 400 kV Transmission lines with one / two circuits and one / two conductors per phase  | Reliability level 1 corresponding to 50 years return period  |
| 66 kV to 400 kV Transmission lines with more than 2 circuits;<br><br>400 kV Transmission lines with more than two conductors per phase;<br><br>765 kV and 1150 kV transmission lines   | Reliability level 2 corresponding to 150 years return period |
| Special towers / Pole ;<br><br>Tall River crossing towers / Pole;<br><br>Multicircuit towers / Pole whose full scale prototype can not be tested due to limitation of testing facility | Reliability level 3 corresponding to 500 years return period |

- (h) The prototype of normal towers shall be tested as per relevant IS. However, it shall not be mandatory to test prototype of tall river crossing towers and other special towers designed for reliability level-3 (500 year return period).
- (i) Drag coefficient as per Table 19 shall be considered for design of tower:

**Table 19**

| <b>Solidity Ratio</b> | <b>Drag coefficient</b> |
|-----------------------|-------------------------|
| Upto 0.05             | 3.6                     |
| 0.1                   | 3.4                     |
| 0.2                   | 2.9                     |
| 0.3                   | 2.5                     |

|               |     |
|---------------|-----|
| 0.4           | 2.2 |
| 0.5 and above | 2.0 |

- (j) Delta configuration towers shall not be used for 765 kV single circuit line.
- (k) The suspension towers with V-type insulator string and / or tension towers shall be used in urban and forest area to reduce RoW
- (l) For lattice tower, mild steel and high tensile steel sections of Grade E250 and E350 as per IS 2062) shall be used in towers and their extensions.
- (m) For towers in snow bound areas, steel sections shall conform to Grade C of IS 2062.
- (n) The fabricated tower parts and stubs of transmission lines passing through coastal / creek regions shall have following minimum mass and thickness of zinc coating (Table 20):

**Table-20**

|  | <b>Minimum mass of zinc coating (gram/sq m)</b> | <b>Average coating thickness of zinc coating (micron)</b> |
|--|---|---|
| <b>For plates and sections below 5 mm</b>        | 900   | 127   |
| <b>For plates and sections of 5 mm and above</b> | 610   | 87  |

- (o) The danger plates, number plates, phase plates, circuit plates, anti-climbing devices, bird guards, day and / or night visual aids and markers for denoting transmission line or structures as per requirements of Directorate of Flight Safety or International Civil Aviation Organization and the bird diverters, wherever required, shall be provided.
- (p) Spike type Bird guards on the Upper (tie members) & Lower main members and also on Plan bracings in the barrel of the tower at all the cross arm levels to prevent birds from making nests.
- (q) Each tower shall be earthed such that tower footing impedance does not exceed 10 ohms.
- (r) Pipe type or Counterpoise type earthing or multiple earthing or use of environmental friendly earth enhancement material shall be used for earthing of towers to achieve specified tower footing impedance. If still, specified tower footing impedance is not achieved, line surge arresters shall be used on phase conductors connected to that tower to reduce back flashover.
- (s) Additional earthing shall be provided on towers after every 7 to 8 kms distance for direct earthing of shield wires.

(5) Foundations

- (a) The type of foundation for towers shall be designed based on a geotechnical investigation of the soil properties.
- (b) Pile type foundation shall be used for towers located in river or creek bed or on bank of river having scourable strata or in areas where river flow or change in river course is anticipated, based on detailed soil investigation, maximum flood discharge of the river during past 20 years, maximum velocity of water, highest flood level, scour depth & anticipated change in course of river based on river morphology data of at least past 20 years to ensure availability and reliability of the transmission line.
- (c) Structural design of foundations shall be done by limit state method with minimum overload factor as 1.1.

(6) Insulators, Insulator Strings and Hardware Fittings

- (a) The insulator shall have proven life of not less than 35 years.
- (b) In a transmission line, for a particular Site Pollution Severity (SPS) class, minimum specific creepage distance (corresponding to the line to line highest system voltage) shall be as specified in Table 21.

**Table 21**

| <b>Site Pollution Severity (SPS) class (As per IS 16683:Part-I:2018)</b> | <b>Specific Creepage Distance (in mm/kV)</b> |
|--|--|
| Very Light or Light or Medium  | 20   |
| Heavy  | 25   |
| Very Heavy   | 31   |

- (c) The silicone content in composite silicone rubber insulator or RTV silicone coating shall be minimum 30%.
- (d) Number of insulators, insulator profile, profile parameters and dimensions shall be selected based on electrical system parameters and site specific factors like altitude above mean sea level, expected environmental and pollution conditions complying with relevant IS or IEC standards.
- (e) For river crossings or power line crossings (66kV or above), railways or road crossings (express way, national highway & state highway) minimum two

sets of long rod insulators or two sets of disc insulator strings per phase per circuit shall be used.

- (f) Electro-mechanical strength of insulator shall be selected such that:
  - (i). under 100% design wind loading conditions, the load on insulator string shall not exceed 70 % of its electro-mechanical strength;
  - (ii). under everyday temperature and nil wind conditions, the load on insulator string shall not exceed 25% of its electro-mechanical strength.
- (g) Grading or Corona ring shall be provided with Composite silicone rubber insulators for 132 kV and above voltage class lines and with porcelain or glass insulators for 400kV and above voltage class lines to control high concentration of electric field.

**(7) Accessories for Conductor and Earthwire-**

The accessories required for the conductor and earthwire viz. mid-span compression joints, repair sleeve, T-connector, flexible copper/ or aluminium bond, vibration dampers, spacer or spacer-dampers, earthwire clamps etc. shall be used as suitable for type and size of conductor and earthwire used for the transmission line.

**(8) Crossing by a transmission line:**

- (a) For crossing of power line of 400 kV or above voltage class, large angle towers of deviation angle of 30-60 degree & designed for dead end condition, with required body extension, shall be used on either sides of the power line.
- (b) For crossing of power line of 110 kV, 132 kV, 220 kV and 230 kV voltage class, the tension towers with required body extension shall be used on either sides of the power line and the crossing of power lines of 66 kV class shall be done with any type of towers (suspension /or tension) with required body extension.

(9) The Route of transmission line (66 kV and above voltage level) shall be clearly identified as normal section (s) without constraint, section (s) through forest area, and section (s) through urban areas / populated area / approach section near substations and normal design span for various voltage level transmission lines be as indicated in the Table 22 below shall be adopted.

**Table 22**

|  | Normal design span (m) |             |                               |
|--|------------------------|-------------|-------------------------------|
|  | Normal route           | Forest area | Urban area / Populated area / |
|  |                        |             |                               |

| <b>Voltage (kV)</b>                         | <b>without constraint</b> |     | <b>approach section near substation</b> |
|---|---------------------------|-----|---|
| ± 800 kV HVDC<br>±500 kV HVDC<br>1200 kV AC | 400                       |     |   |
| 765 kV / 400 kV AC                          | 400                       | 300 | 250                                     |
| 230 kV/ 220 kV AC                           | 325 to 350                | 250 | 200                                     |
| 132 kV                                      | 320                       | 200 | 150                                     |
| 110 kV AC                                   | 305                       | 200 | 150                                     |
| 66 kV AC                                    | 250                       | 150 | 100                                     |

Provided that reduced design span for pole or narrow base structure may be considered based on techno-economic analysis.

(10)Cables and Gas Insulated Lines (GIL):

Wherever in small stretch, the construction of an overhead transmission line is not possible due to space constraints or right of way problems, XLPE cable or Gas Insulated Lines (GIL) conforming to relevant IS or IEC standard, and rated for power flow requirement shall be considered for transmission of power based on techno-economic analysis.

**87. Condition Assessment of Towers and earthing system:**

- (1) Utilities shall assess the condition of structure of towers, conductors, earthwire, all associated accessories, foundation & earthing system periodically using modern techniques & diagnostic tools and shall take appropriate action, wherever abnormality is noticed.
- (2) For condition assessment of conductors, clamps, connectors, insulators etc., provision for on- line / off- line diagnostic tools and equipment shall be made.
- (3) On- line tools shall include thermo-vision camera for detection of hot spots, corona camera and live line punctured insulator detector.
- (4) Off- line tools shall include insulation resistance measuring instrument, contact resistance measuring instrument and tower footing impedance measuring tool.
- (5) The on line (as in built feature of Numerical relay) and off-line fault locator shall be used for locating the transmission line faults.

- (6) Patrolling of the lines shall be carried out on half yearly basis for smooth and trouble free operation of line and activities like replacement of missing members / bolts, coping of chimney to avoid rusting of stubs, identifying rusted members, missing earthing connections etc.
- (7) During patrolling, if any unauthorized construction/use/storage under & around the towers is observed, local administrative authority should be immediately informed for assistance and necessary action.
- (8) Frequency of patrolling of transmission lines should be increased for the vulnerable tower locations (thunder prone, cyclonic prone area) and in theft prone areas. Members/ nuts/ bolts, if found missing during patrolling, shall be replaced to avoid failure of towers.
- (9) In case repeated failures of towers designed as per old standard / IS 802-1977 is observed, the towers shall be Strengthened by using hip bracings upto bottom cross arm level.
- (10) The nuts & bolts of section above bottom cross arm level shall be rechecked & re-tightened after 5 years of commissioning of the transmission line and every 10 years of service thereafter.
- (11) Condition of earthing shall be checked after 10 years of commissioning of transmission line & every 5 years of service thereafter and corrective action, if required may be taken

#### **88. Use of Helicopter and UAV:**

For survey, erection of towers, stringing of conductors and patrolling of transmission line in difficult and inaccessible terrains, use of helicopter or Unmanned Aerial Vehicle (UAV) shall be considered.

Provided required clearance from Director General Civil Aviation (DGCA) or any other competent authority shall be obtained before taking up such activity.

#### **89. Use of GIS platform :**

Transmission system asset mapping, route alignment and optimization of route of new transmission line for transmission projects shall be carried out on BHUVAN GIS platform of National Remote Sensing Centre (NRSC).

## **PART- B**

### **ELECTRIC LINES (33 KV AND BELOW)**



**90. General- (1)** The lines shall be constructed keeping in view the prime factors of safety as well as electrical and mechanical design considerations.

(2) The Owner who is connecting his new installation has to abide by the Central Electricity Authority (Technical Standards for Connectivity to the Grid) Regulations, 2007 and Central Electricity Authority (Technical Standards for Connectivity of the Distributed Generation Resources) Regulations, 2013, as amended from time to time.

(3) The Owner shall arrange all required consents/approvals including civil aviation, road, river, rail, canal, power line crossings and environmental and forest clearances etc. from the concerned authorities.

(4) The Owner in accordance with the requirements of construction shall arrange right of way and way leave clearance:

Provided that compensation for right of way and way leaves shall be given as per applicable law, rules and regulations, guidelines/directives of local administrative/revenue authorities.

(5) The RoW width for urban areas:

(a) 33kV overhead lines for different types of structures, commonly used ACSR conductor (with maximum operating temperature of 85 degree) & normal design span

(b) 33kV lines with covered conductor mounted on pole type structure shall be as indicated below:

| <b>Conductor</b>                  | <b>Structure Type</b>                             | <b>Design Span (in m)</b> | <b>String Type</b>    | <b>RoW (in m)</b> |
|-----------------------------------|---|---------------------------|-----------------------|-------------------|
| Commonly used ACSR Bare conductor | Lattice type/ Steel pole                          | 250                       | "I" String/Suspension | 15 meter          |
|                                   |   |                           | Tension               |                   |
|                                   |   | 150                       | "I" String/Suspension | 12 meter          |
|                                   |   |                           | Tension               |                   |
|                                   | Concrete Pole/Rail Pole/H Pole/ Single Steel Pole | 100                       | Pin Insulator         | 9 meter           |
|                                   |   | 60                        | Pin Insulator         | 8 meter           |

|         |      |     |  |         |
|---------|------|-----|--|---------|
| Covered | Pole | 100 |  | 6 meter |
|---------|------|-----|--|---------|

**91. Electrical Design Parameters of the Electric Lines-** (1) The electrical design parameters of the electric lines for altitude upto 1000 m above MSL shall be as indicated in Table 19 below:

**Table 19**

| Parameter   | 33 kV | 22 kV | 11 kV | 0.415 kV |
|---|-------|-------|-------|----------|
| Nominal system voltage (kV)   | 33    | 22    | 11    | 0.415    |
| Highest system voltage (kV)   | 36    | 24    | 12    | 0.450    |
| Frequency (Hz)  | 50    | 50    | 50    | 50       |
| Lightning impulse withstand voltage (kV <sub>peak</sub> )               | 170   | 125   | 75    | -        |
| Power frequency withstand voltage (kV <sub>rms</sub> ) in dry condition | 75    | 50    | 28    | 3        |

- (2) For the electric lines at altitudes higher than 1000 m above MSL, basic insulation level (BIL), impulse withstand voltage requirements shall be kept higher than those indicated in Table 19 as per relevant standards and practices.
- (3) System Earthing shall be as per Central Electricity Authority (Measures Relating to Safety and Electricity Supply), Regulations, 2010 as amended from time to time.

## **92. Design and Construction of Electric Lines and Associated Equipment**

- (1) The design and construction of the electric lines shall comply with the relevant IS.
- (2) The system shall be constructed so as to ensure:
- (a) voltage conditions are within permissible levels;
  - (b) improvement of reliability and security of power supply;
  - (c) improvement in quality of supply;
  - (d) adequate capacity for load growth at least for next 5 years.

- (3) Independent feeders shall be provided for essential loads such as water works, hospitals, defence, railways, airports and other sensitive installations and for selected consumers on request.
- (4) Separate rural feeders for feeding irrigation load and domestic load shall be provided.
- (5) Multi-circuit multi-voltage lines shall be adopted by the owner as per requirement.
- (6) Extension of existing lines shall be carried out after ensuring that the limits of voltage variations on the lines are not exceeded.
- (7) The reliability and security of supply shall be improved by use of sectionalizers, auto re-closers, ring main units (RMUs) and fault passage indicators as per techno economic considerations.

**93. Routing of Overhead Electric Lines-**(1) The route of the electric line shall be as short as possible.

(2) The routing of an electric line shall normally be avoided through following areas:

(a) Protected and reserved forest:

Provided that in case it is not possible to completely avoid the forests or areas having large trees, keeping in view the overall economy, the route shall be aligned in such a way that cutting of trees is minimized.

(b) National Parks and Wild Life Sanctuaries

(c) Restricted areas such as civil and military airfields and care shall be taken to avoid aircraft landing approaches.

(d) Educational institutions, large habitations and densely populated areas

(e) Rough and difficult country side, and natural obstructions, fruit gardens, lakes, rivers etc.

(f) The electric line shall normally not cross over cremation grounds and shall be far off from slaughterhouses and garbage dumping grounds to prevent interruptions by bird hits.

(3) The electric line shall be close to a road for approach during construction and ease of maintenance.

(4) Angle points in the route shall be minimized.

(5) Railway and road crossings shall be minimum on the line route and in case it is not possible to avoid the same, the crossings at right angles shall be preferred but the crossing shall not be less than 60 degrees in any case.

#### **94. Supports (Poles and Towers)-**

- (1) Supports shall conform to relevant IS.
- (2) The supports shall be poles or narrow based lattice towers with fully galvanised structure as per site requirement.
- (3) (a) The poles shall be pre-cast concrete (PCC) pole, pre-stressed cement concrete (PSCC) pole, rolled steel joist, rail pole, spun pole, H beam or steel tubular pole as required:
  - (b) PCC and PSCC poles shall not be used at cut-points and as end poles:
  - (c) In coastal areas, higher strength poles like rail poles or spun poles shall be used.
- (4) Erection of poles shall be carried out in accordance with the provisions of relevant IS.
- (5) In hilly areas appropriate snow or ice loading shall be considered for design of poles and towers.
- (6) For locations involving long spans or higher clearances on account of crossing of power or communication lines or a railway line, specially designed poles/lattice towers or underground cable shall be used as per requirement.
- (7) Double pole structure shall be used as per site conditions ensuring safe operation of lines.
- (8) The height of the pole above the ground level, length of pole below ground and working load shall be decided taking into consideration wind zone, terrain, topography, and the statutory clearances required.

#### **95. Line Span-**

- (1) The span shall be within the range specified by relevant IS.
- (2) Line span shall be decided taking into consideration topography, wind pressure, type of support, conductor configuration and ultimate tensile strength of conductor.

- (3) Uniform span shall be maintained as far as possible between consecutive pole structures.
- (4) While constructing a line, if a road crossing occurs at mid span, then a pole shall be placed on one side of the road so as to avoid mid span at the road crossing.
- (5) While crossing another power line, the lower voltage line shall be underneath:  
Provided that the lower line shall normally not cross at mid span of the upper line.
- (6) While placing poles on high ground, shorter poles can be used while maintaining proper ground clearance at the middle of the span.
- (7) Poles shall normally not be placed along the edges or cuts or embankments of creeks and streams.
- (8) At all the places where the new line crosses over roads or another existing line, adequately earthed guard wire mesh below the line shall be provided to avoid the conductor of the new line falling over the areas below, in case of any break:  
Provided that in cases where the line passes below an existing line, the guard wire mesh shall be provided above the new line under construction.

**96. Maximum stresses and factors of safety-**The permissible stresses and minimum factor of safety shall be as per Central Electricity Authority (Measures Relating to Safety and Electricity Supply), Regulations, 2010 as amended from time to time.

**97. Stay Arrangements-** (1) Galvanized iron stay wires and stay rods of adequate size and minimum tensile strength complying with relevant IS shall be used.

- (2) The stays shall be provided at:
  - (a) angle locations;
  - (b) dead end locations;
  - (c) tee off points;
  - (d) steep gradient locations;
  - (e) cut-points;
  - (f) along the straight run at minimum two locations in 1 km.
- (3) For double pole structure, four stays along the line, two in each direction and two stays along the bisection of the angle of deviation or as required depending on the angle of deviation shall be provided.

- (4) When two or more stays are provided on the same pole, each stay shall be grouted entirely separate from the other.
- (5) The angle between the pole and stay wire shall be about 45 degrees and in no case it shall be less than 30 degrees.
- (6) Stays shall be anchored either by providing base plates, angle iron or rail.
- (7) Stay wires shall be connected to the pole with IS complaint Porcelain Guy Strain Insulator
- (8) The insulator shall be inserted in the stay wire at a height of minimum 3 m vertically above the ground level.

**98. Protective Guard, Anti Climbing Devices and Danger Plates** - Protective Guard, anti-climbing devices and danger plates shall be provided in accordance with Central Electricity Authority (Measures Relating to Safety and Electricity Supply), Regulations, 2010 as amended from time to time.

**99. Insulators, Insulator Strings and Hardware Fittings-**

- (1) Insulators and its fittings shall confirm to relevant IS.
  - (a) Pin insulators shall be used on lines up to 33 kV voltage level as per requirement.
  - (b) Shackle insulators, using strap type fittings or U-clamp fittings, shall be used in lines below 650 volts.
  - (c) Suspension and Tension insulator strings with disc insulators or long rod insulators offering equivalent performance shall be used on 33 kV or 22 kV or 11 kV lines:  
 Provided that the number of insulators and creepage distance shall be selected based on electrical system parameters taking into account altitude of site, expected environmental and pollution conditions etc.
  - (d) for critical locations with high pollution level, anti-fog type insulators or polymer insulators may be used for better performance.
  - (e) Disc Porcelain insulators with Ball and Socket type or Tongue and Clevis type fittings shall be used.
- (2) Insulator and insulator string rating shall be selected such that:
  - (a) Under ultimate design wind / snow loading conditions, the load on insulator string shall not exceed 70% of its selected rating.
  - (b) Under everyday temperature and no wind/ snow conditions, the load on the insulator string shall not exceed 25% of its selected rating.
- (3) The insulation shall be designed to avoid excessive concentration of electrical stresses in any section or across leakage surfaces.

### **100. Cross-Arms**

- (1) cross-arms and the clamps shall be hot dipped galvanized conforming to relevant IS
- (2) Welding at site should be avoided as far as possible, in case welding becomes necessary, the joint shall be covered with cold galvanizing paint.

### **101. Conductor**

- (1) The size of the conductor shall depend upon the voltage regulation, factor of safety, power to be transmitted, length of line, line voltage and mechanical strength desired.
- (2) Aluminium Conductor Steel Reinforced (ACSR) or equivalent All Aluminium Alloy Conductors (AAAC), All Aluminium Conductor (AAC), Aluminium Alloy Conductor Steel Reinforced (AACSR) or HTLS conductors along with requisite accessories shall comply with relevant IS.
- (3) The configuration of conductors on the line can be triangular, horizontal or vertical depending upon the voltage level of the lines, terrain, right of way and clearances to be maintained:  
Provided that in case clearance from a building is difficult to secure, vertical arrangements of the conductor shall be adopted.
- (4) Suitable insulating paint shall preferably be provided on bare conductors in coastal areas to prevent corrosion as well as in power theft prone areas.

**102. LT Spacers-**To avoid clashing and accidental mutual touching of bare overhead conductors on LT lines, spacers of adequate dielectric strength, which can be either spiral or composite shall be provided in between conductors at appropriate locations in different spans (particularly for lines having longer spans or lines having large sags encountering high winds).

### **103. Cables-**

- (1) Underground cables or aerial bunched cables (ABC) or covered conductor of adequate rating conforming to relevant Standards can also be used for supplying power.
- (2) In coastal areas underground cables shall be used.
- (3) PVC cables shall not be used in systems other than LT system.
- (4) Aerial bunched cables or insulated cables or covered conductor shall be used in the congested, theft and accident-prone areas.

- (5) Underground Cables shall normally be laid in trenches as per the relevant standards and utility practices:  
Provided that direct burying of underground cables shall not be adopted except where cables enter and take off from a trench:  
Provided further that cables may be laid in pipes or cables with co-extruded pipes may also be laid, though trenchless method as per the site requirement.
- (6) The underground cables shall be segregated by running in separate trenches or on separate racks or in separate pipes.
- (7) Cable trenches or pipes shall not be run through oil rooms and these shall be properly sloped so as to drain freely any water, which may enter.
- (8) Cables shall not be laid directly on trench floor.

#### **104. Service Line**

- (1) The service line shall be provided with insulated conductor, armoured cable or underground cable.
- (2) The service line shall have adequate margin to take care of load growth for at least five years.
- (3) Over-head service connection shall be provided either through independent service connection or through LV box.
- (4) No tapping of service line shall be permitted for supplying power to any other consumer.
- (5) Feeder pillar-box shall be used for providing underground service connection through cable to more than three or four consumers.
- (6) The meters for the consumer connections shall be provided in accordance with the Central Electricity Authority (Installation and Operation of Meters) Regulations, 2006as amended from time to time.

#### **105. Surge Arrester**

- (1) Surge Arrester shall be as per relevant IS.
- (2) The surge arresters (SAs) shall be placed at the terminal points of the lines and also at the junction points of cables and bare overhead conductor lines.
- (3) For 33 kV, 22 kV and 11 kV lines, surge arresters having rated voltage of 30 kV<sub>rms</sub>, 20 kV<sub>rms</sub> and 9 kV<sub>rms</sub> and discharge current rating of 10 kA, 7.5 kA and 5 kA, complying with relevant IS, shall be used respectively.



**106. Earthing:** Earthing shall be as per relevant IS and Central Electricity Authority (Measures relating to Safety and Electricity Supply) Regulations, 2010 as amended from time to time.

**107. Protection of 33 kV, 22 kV, 11 kV and LT System**

- (1) The protection scheme shall be finalized by the Owner based on prudent utility practice.
- (2) An earth leakage protective device shall be provided at consumer premises as per requirement of Central Electricity Authority (Measures Relating to Safety and Electricity Supply), Regulations as and when these are notified by the Authority.

**108. Repeal and Saving**

- (1) The Central Electricity Authority (Technical Standards for Construction of Electrical Plants and Electric Lines) Regulations, 2010 is hereby repealed.
- (2) Notwithstanding such repeal, anything done or purported to have been done under the repealed regulations shall be deemed to have been done or purported to have been done under the relevant provisions of these regulations.

**109. Relaxation of Regulations-** The Authority may, by order and for reasons to be recorded in writing, relax any of provisions of these regulations in respect of the matters referred to the Authority on case to case basis.

**SCHEDULE- I**

**[See Regulation 10 (10)]**

**List of Electrical Protection Functions for Thermal**

## Generating Units

### 1. Generator

| Sl. No. | Protection Function  | Remarks   |
|---------|--|---|
| (a)     | Generator differential protection (87G)  |   |
| (b)     | 100% stator earth fault protection (64G)   | For units of 100 MW and above.  |
| (c)     | 95% stator earth fault protection (64G1)   | For units less than 100 MW.   |
| (d)     | Standby stator earth fault protection (64G2)                                       |   |
| (e)     | Inter-turn fault protection(87TG)  | Applicable where split winding in Stator is provided and if six terminals are available.                              |
| (f)     | Loss of field protection (40G)   | To be duplicated for units of 500 MW and above.   |
| (g)     | Negative phase sequence current protection (46G)                                   |   |
| (h)     | Low-forward power and Reverse power interlock for steam turbine generator (37/32G) | Preferably 3-phase power relays shall be provided. Both the relays shall be duplicated for units of 500 MW and above. |
| (i)     | Rotor earth fault protection - two stages (64F1/F2)                                |   |
| (j)     | Definite time over-voltage protection (59G)  |   |
| (k)     | Generator under frequency protection (81G)   |   |

|     |  |  |
|-----|--|--|
| (l) | Over-fluxing protection for generator (99G)  | To be provided for units of 500 MW and above in duplicate. |
| (m) | Overload protection for generator (51G)  |  |
| (n) | Back- up impedance protection, 3 pole (21G)  |  |
| (o) | Overheating (winding and/ or bearing) (49G)  | Alarm only.  |
| (p) | Instantaneous and time delayed over current protection on high voltage side of excitation transformer (51) |  |
| (q) | Generator pole slipping protection (98G)   |  |
| (r) | Accidental back energisation protection (50GDM)  |  |
| (s) | Generator circuit breaker failure protection (50ZGCB)  | To be provided for GCB scheme only.                        |

Note: In case digital multifunctional generator protection system (MGPS) is provided, the protection systems for generator shall be duplicated for units of 100MW and above. Each MGPS shall preferably be provided with individual inputs from CTs and VTs and connected to the independent set of hand-reset trip relays, such that one set is always available in case of testing and mal-operation of the other set. If the MGPS does not include any protection mentioned in the table above, separate discrete protection shall be provided for the same. The MGPS shall preferably have continuous self-monitoring and testing facilities.

## 2. Generator Transformer

| Sl. No. | Protection Function   | Remarks  |
|---------|---|--|
| (a)     | Overall differential protection (87OA)  |  |
| (b)     | Generator transformer differential protection (87GT) for single phase bank  |  |
| (c)     | Restricted earth fault protection for generator transformer (87NGT)   |  |
| (d)     | Over head line connection differential protection (87L)   | For 3 single phase banks, if 87L includes HV winding, separate 87NGT is not mandatory. |
| (e)     | Back- up earth fault protection on generator transformer HV neutral (51NGT)   |  |
| (f)     | Over-fluxing protection for generator transformer (99GT)  | To be duplicated for units of 500 MW and above.  |
| (g)     | Back- up non-directional over-current protection in all phases on HV side of generator transformer (51GT)           |  |
| (h)     | Generator transformer oil temperature indicator (OTI) trip (49Q) and winding temperature indicator (WTI) trip (49T) |  |
| (i)     | Generator transformer Buchholz (63), Pressure relief valve (PRV)/ other mechanical protections                      |  |

|     |   |   |
|-----|---|---|
| (j) | Pole discrepancy protection of generator transformer breaker (16Z)                            | To be provided, if single pole breakers are used. |
| (k) | Breaker failure protection of generator transformer breaker (50Z)                             |   |
| (l) | Start-up earth fault protection for LV and HV winding of generator transformer and UATs (64T) | To be provided for GCB scheme only.               |

### 3. Unit Auxiliary Transformer(s)

| Sl. No. | Protection Function                              |
|---------|--|
| (a)     | Differential protection (87UAT)                  |
| (b)     | LV back-up earth fault protection (51NUAT)       |
| (c)     | LV restricted earth fault (87NUAT)               |
| (d)     | Back-up over-current protection (51UAT)          |
| (e)     | OTI(49Q) and WTI (49T) trip                      |
| (f)     | Buchholz (63), PRV/ other mechanical protections |

### 4. Station- Transformer(s)

| Sl. No. | Protection Function                  |
|---------|--------------------------------------|
| (a)     | Differential current protection (87) |

|     |  |
|-----|--|
| (b) | Restricted earth fault protection for LV winding (87NLV) |
| (c) | Restricted earth fault protection for HV winding (87NHV) |
| (d) | Back-up over-current protection on HV side (51)          |
| (e) | Back-up earth-fault protection (51N)                     |
| (f) | Over-fluxing protection (99)                             |
| (g) | Buchholz protection (63)                                 |
| (h) | Winding temperature high (49T)                           |
| (i) | Oil temperature high (49Q)                               |
| (j) | Pressure relief valve trip (PRV)                         |
| (k) | Breaker failure protection (50Z)                         |

## **SCHEDULE- II**

**[See Regulation 12 (3)]**

### **Design Requirements for Ash Handling System**

#### **A. Design Requirements for Ash Handling System of Pulverised Fuel Steam Generators**

1. The capacity of ash handling systems, as a percentage of maximum ash generated corresponding to firing of worst coal or lignite at BMCR, shall not be less than the following:
  - (a) Fly ash system
    - (i) ESP fly ash and chimney ash : 90%
    - (ii) Air preheater ash : 5%

- (b) Bottom ash system
  - (i) Furnace bottom ash : 25%
  - (ii) Economiser ash : 5%

2. Ash removal rate shall meet the following criteria:

- (a) Fly ash system : 8 hour collection in 6 hours
- (b) Bottom ash system : intermittently once or twice in a shift for jet pump system;  
  
: Continuous for submerged scrapper conveyer system and dry system.

3. Ash handling system shall have the provision for following standby arrangement:

- (a) Bottom ash system - 100% standby for jet pumps

Or

100% standby for submerged scrapper conveyor (SSC)

- |     |                     |   |  |
|-----|---------------------|---|--|
| (b) | Fly ash system      | - | 100% standby for vacuum pumps, collector tanks, wetting heads;   |
|     |                     | - | 100% standby blowers for intermediate and storage silos;   |
|     |                     | - | 50% standby for air compressors to be used for transporting ash.                                       |
| (c) | Ash slurry disposal | - | One pump stream as operating standby and one pump stream as maintenance standby for wet slurry system; |
|     |                     | - | One standby stream for high concentration slurry system.   |

**B. Design Requirements for Ash Handling System of Fluidised Bed Steam Generators**

1. The capacity of ash handling systems, as a percentage of maximum ash generated corresponding to firing of worst coal or lignite at BMCR, shall not be less than the following:

(a) Fly ash system

- |                                 |   |     |
|---------------------------------|---|-----|
| (i) ESP fly ash and chimney ash | : | 80% |
| (ii) Air preheater ash          | : | 5%  |



(b) Bottom ash system

(i) Furnace bottom ash : 30- 40%

(ii) Economiser ash : 5%

2. Ash removal rate shall meet the following criteria:

(a) Fly ash system : 8 hour collection in 6 hours

(b) Bottom ash system : Continuous

3. Ash handling system shall have the provision for following standby arrangement:

(a) Bottom ash system - 100% standby for drag link chain conveyor

(b) Fly ash system - 100% standby for vacuum pumps, collector tanks, wetting heads;

- 100% standby blowers for intermediate and storage silos;

- 50% standby for air compressors to be

used for transporting ash.

- (c) Ash slurry disposal
  - One pump stream as operating standby and one pump stream as maintenance standby for wet slurry system;
  - One standby stream for high concentration slurry system.

### SCHEDULE- III

[See Regulation 36 (7)]

The minimum Load for Continuous Operation for Various Types of Hydraulic Turbines

| <b>Sl. No.</b> | <b>Type of turbine</b>   | <b>Minimum load for continuous operation (percent)</b> |
|----------------|--------------------------|--|
| (a)            | Pelton or Kaplan or Bulb | 30   |
| (b)            | Deriaz                   | 40   |
| (c)            | Francis                  | 50   |
| (d)            | Propeller                | 85   |

## SCHEDULE- IV

[See Regulation 40 (12) (f)]

### Minimum Protections to be provided for Hydro- electric Generating Units

#### 1. Generator

| Sl. No. | Protection functions                 | Size of generating unit |                        |                      |
|---------|--------------------------------------|-------------------------|------------------------|----------------------|
|         |                                      | Small<br>(<10 MVA)      | Medium<br>(10-100 MVA) | Large<br>(> 100 MVA) |
| (a)     | Differential (87G)                   | Y                       | Y                      | Y                    |
| (b)     | 95 % stator earth fault (64G1)       | Y                       | Y                      | Y                    |
| (c)     | 100 % stator earth fault (64G2)      | N                       | Y                      | Y                    |
| (d)     | Backup impedance (21G)               | N                       | Y                      | Y                    |
| (e)     | Voltage controlled over current (51) | Y                       | N                      | N                    |
| (f)     | Negative phase sequence (46G)        | Y                       | Y                      | Y                    |
| (g)     | Loss of excitation (40G)             | Y                       | Y                      | Y                    |
| (h)     | Reverse power (37/32G)               | Y                       | Y                      | Y                    |
| (i)     | Pole slipping (98G)                  | N                       | N                      | Y                    |
| (j)     | Stator overload (49S)                | Y                       | Y                      | Y                    |
| (k)     | Over voltage (59G)                   | Y                       | Y                      | Y                    |
| (l)     | Under frequency (81G)                | Y                       | Y                      | Y                    |
| (m)     | Dead machine (27/50G)                | N                       | N                      | Y                    |

|  |                         |   |   |   |
|--|-------------------------|---|---|---|
| (n)  | Rotor earth fault (64R) | Y | Y | Y |
| <b>Note:</b> Y- Required; N- Not required. |                         |   |   |   |

## 2. Excitation Transformer

| Sl. No.                   | Protection functions                        | Size of generating unit |                        |                         |
|---------------------------|---|-------------------------|------------------------|-------------------------|
|                           |   | Small<br>( $< 10$ MVA)  | Medium<br>(10-100 MVA) | Large<br>( $> 100$ MVA) |
| (a)                       | Restricted earth fault (64)                 | Y                       | Y                      | Y                       |
| (b)                       | Instantaneous and IDMT over current (50/51) | Y                       | Y                      | Y                       |
| (c)                       | Winding temperature (49)                    | Y                       | Y                      | Y                       |
| <b>Note:</b> Y- Required. |   |                         |                        |                         |

## 3. Generator Transformer

- (a) Generator transformer differential protection (87T)
- (b) Restricted earth fault protection (64GT)
- (c) IDMT over current protection (51)
- (d) Neutral grounding back-up earth fault protection (51NGT)
- (e) Over head line connection differential protection (87L)
- (f) Overfluxing protection (99GT)
- (g) Monitoring of Insulation of low voltage bushing (59T)
- (h) Buchholtz relay (63)

- (i) Winding temperature protection (49T)
- (j) Oil temperature protection (49)
- (k) Pressure relief valve (PRV)

#### **4. Generator and Generator Transformer**

- (a) Overall differential protection (87OA)
- (b) Breaker Failure Protection (50Z)

#### **5. Unit Auxiliary Transformer**

- (a) Restricted earth fault protection (64)
- (b) Instantaneous and IDMT over current protection on high voltage winding (50/51)
- (c) Neutral grounding back-up E/F protection (51NGT)
- (d) Winding temperature protection (49T)

#### **6. Station Auxiliary Transformer**

- (a) Restricted earth fault protection (64)
- (b) Instantaneous and IDMT over current protection on high voltage winding (50/51)
- (c) Neutral grounding back-up earth fault protection (51NGT)
- (d) Winding temperature protection (49T)

## SCHEDULE- V

[See Regulation 48(3)]

### Protection Details of Transmission Lines, Transformers, Reactors and Bus Bars

#### 1. Transmission Line Protection

| No. | Protection  | 765 kV | 400 kV | 220 kV/230 kV  | 132 kV/110 kV/ 66 kV  |
|-----|---|--------|--------|--|-----------------------|
| (a) | Main I- Distance protection*  | Y      | Y      | Y  | Y (for 132 kV/110 kV) |
| (b) | Main II- Distance protection* or directional comparison protection or phase segregated line differential protection | Y      | Y      | Y/N<br>'N' if Directional IDMT over current and earth fault back up protection is provided otherwise 'Y' | N                     |
| (c) | Directional inverse definite minimum time (IDMT) type earth fault relay   | Y      | Y      | 'Y' if both Main-I & Main-II are distance protections otherwise 'N'                                      | N                     |
| (d) | Directional IDMT over current and earth fault back up protection  | N      | N      | 'Y' if Main-II is not provided otherwise 'N'   | Y                     |
| (e) | Two stage over voltage protection   | Y      | Y      | Y/N  | Y/N                   |

|     |                 |   |   |  |                             |
|-----|-----------------|---|---|--|-----------------------------|
| (f) | Auto reclosing# | Y<br>(Single<br>phase<br>and<br>three<br>phase) | Y<br>(Single<br>phase<br>and<br>three<br>phase) | Y<br>(Single<br>phase and<br>three<br>phase) | Y/N<br><br>(three<br>phase) |
|-----|-----------------|---|---|--|-----------------------------|

**\*For short line (less than 10kms) or cable or combination of overhead line and cable, line differential protection shall be used with built-in backup distance protection.**

**# For cable or combination of overhead line and cable, autoreclosing shall not be provided.**

Note: (1) Y- Required; N- Not required; Y/N- Optional.

(2) Transmission lines with distance protection shall, in general, have carrier aided or fibre optic based inter-tripping or blocking feature.

(3) Separate cores of current transformer and voltage transformer shall be used for Main-I and Main-II.

## 2. Transformer Protection

| Sl. No. | Protection  | 765 kV | 400 kV | 230 kV/220kV/ 132 kV/110 kV | 66 kV |
|---------|---|--------|--------|-----------------------------|-------|
| (a)     | Differential protection   | Y      | Y      | Y                           | Y     |
| (b)     | Over fluxing protection   | Y      | Y      | Y                           | N     |
| (c)     | Restricted earth fault (REF) protection   | Y      | Y      | Y                           | Y     |
| (d)     | Backup directional over current and earth fault protection (HV and LV side) or impedance protection | Y      | Y      | Y                           | Y     |

Note: (1) Y- Required; N- Not required.

(2) WTI- winding temperature indicator; OTI- oil temperature indicator; OLTC- on load tap changer; PRD- pressure relieve device; OSR- oil surge relay; MOG- magnetic oil gauge; SA- surge arrester.

## 3. Reactor Protection



|     |  |   |   |   |   |
|-----|--|---|---|---|---|
| (e) | Buchholz, WTI and OTI (for 1 MVA and above), MOG with low oil level alarm, OSR for OLTC, PRD, SA on both primary and secondary sides of transformers located outdoors and connected to over head lines | Y | Y | Y | Y |
| (f) | Tertiary winding protection  | Y | Y | Y | N |
| (g) | Over load alarm  | Y | Y | Y | Y |

| Sl. No. | Protection  | 765 kV | 220kV /400 kV |
|---------|---|--------|---------------|
| (a)     | Differential protection   | Y      | Y             |
| (b)     | REF protection  | Y      | Y             |
| (c)     | Reactor backup protection (impedance type or definite time over current (O/C) and earth fault (E/F) protection) | Y      | Y             |
| (d)     | Buchholz, WTI, OTI, MOG with low oil level alarm, SA (if required)  | Y      | Y             |

Note: (1) Y- Required.

(2) WTI- winding temperature indicator; OTI- oil temperature indicator; MOG- magnetic oil gauge; SA- surge arrester.

#### 4. Bus Bar Protection and Local Breaker Backup Protection (breaker failure protection)

Bus bar protection and local breaker backup protection shall be provided in 220kV and higher voltage interconnecting sub- stations as well as in all generating station switchyards. Duplication of bus bar protection shall be done for all main buses of 400kV and above voltage class. The bus bar protection scheme shall be centralized or distributed type and have provision for planned future expansion.

**SCHEDULE- VI**  
**(See Regulation 49)**  
**PART-A**

**Technical Details of Classical HVDC Terminals/ Stations**

1. **General:** The conventional Thyristor (Gate Turn On device) based HVDC converter technology or Line Commuted Converter (LCC) technology or Current Source Converter (CSC) technology shall be used for back to back and long distance bulk power HVDC transmission system. Gate Turn Off devices / other better devices capable of handling similar or higher quantum of power may also be considered.

2. **Design Consideration:** (a) The converter configuration and rating for HVDC installation shall be based on following considerations:

- (i) The amount of power to be transmitted
- (ii) The transmission distance
- (iii) Staging consideration of the project
- (iv) Location of converter station
- (v) The amount of power to be transmitted at the different stages of the project
- (vi) Reliability and availability requirements
- (vii) Loss evaluation
- (viii) Size and weight of the Converter transformers for transport
- (ix) Electrical characteristics of sending and receiving end power system to which HVDC transmission system is connected

**Note:** The DC power rating shall include nominal, reverse, forward and overload power levels, specific loading cycle and weightage factor to calculate load losses.

(b) Electric design of HVDC transmission lines shall take into account the following considerations:

- (i) Corona performance (Corona loss, Radio Interference, Audible Noise, Electric field and ion current in the vicinity of the line)
- (ii) Air Characteristic
- (iii) Insulator performance

(c) The minimum conductor height above Ground level shall be selected mainly on the basis of ensuring human safety, Ground level electric field and ion current density level. The corona loss with  $I^2R$  losses in the conductors shall be considered for economic choice of the optimum conductor bundle in transmission line.

3. **System Data:** The following environmental, AC & DC system information, shall be considered:

(a) Environmental information:

- (i) Ambient temperature
  - (ii) Humidity, rain fall intensity
  - (iii) Geographical co-ordinates
  - (iv) Isokeraunic level
  - (v) Wind velocity
  - (vi) Seismic Level
  - (vii) Altitude above sea level
  - (viii) Pollution level
  - (ix) Soil Properties
- (b) AC System information:
- (i) Short Circuit Ratio and Minimum & Maximum Short Circuit Current:
  - (ii) System voltage and frequency
  - (iii) Harmonic impedance characteristics
  - (iv) System Voltage distortion
  - (v) System Grounding
  - (vi) Torsional mode frequencies (Sub-synchronous Resonance)
  - (vii) AC system topology
  - (viii) AC system equivalent
  - (ix) MVAR exchange with AC system
- (c) HVDC line or Cable:
- I. In case of overhead lines, the detail information shall include
    - (i) Line length
    - (ii) Conductor type
    - (iii) Conductor configuration
    - (iv) Rated DC Voltage
    - (v) Impulse withstand levels
    - (vi) Tower configuration for the Pole conductors & Dedicated Metallic Return (DMR) conductor or earth electrode
    - (vii) Tower footing impedance
    - (viii) Earth electrode station (if applicable)
  - II. In case of Cable, the detail information shall include
    - (i) Cable length
    - (ii) Cable size and insulation
    - (iii) Rated and maximum DC voltage
    - (iv) Current rating
    - (v) Capacitance and resistance at rated load
    - (vi) Impulse withstand levels

#### **4. System Performance:**

The HVDC system shall be designed to meet all performance requirements and shall be compatible to existing system. The HVDC system shall not cause instability to the AC existing Network and shall not adversely affect other nearby HVDC Systems as well as Generating Units. This shall be verified by stability, multi infeed and Sub Synchronous Resonance (SSR) studies.

#### **5. System Studies-** HVDC control parameters and equipment shall be selected by carrying out the following studies at different stages of the project:

- (a) Main circuit parameters;
- (b) Short circuit studies;
- (c) Insulation co-ordination;
- (d) AC, DC and Power Line Carrier (PLC) filter design, rating and performance;
- (e) Reactive power studies, switching arrangement & logic;
- (f) Temporary overvoltage;
- (g) Transient overvoltage, surge arrester stress;
- (h) Runback and run up studies;
- (i) Sub- synchronous resonance (SSR) studies
- (j) AC breaker Transient Recovery Voltage (TRV) and rate of rise of recovery voltage (RRRV) studies;
- (k) Overload study;
- (l) AC equivalent study;
- (m) DC Commutation switch requirements;
- (n) Load flow, stability, modulation and frequency controller design study;
- (o) Dynamic over voltage study;
- (p) Electrical interference study;
- (q) Reliability and availability study;
- (r) Audible noise study;
- (s) Loss calculation;
- (t) Dynamic performance study (DPS);
- (u) Studies for deciding operational logics or sequences;
- (v) Design of electrode line and its impact on dc equipment;
- (w) Commutation failure and recovery study;
- (x) Real Time Simulator based studies;
- (y) HVDC control and protection coordination study;
- (z) AC/ DC system interaction.
- (aa) Muti-infeed studies, if applicable

#### **6. Insulation co-ordination**

- (a) HVDC System shall be suitably protected against Impulses and disturbances external and internal to the system such as switching impulses, lighting impulses, dynamic over voltages and load rejection. The insulation of all equipment shall be properly protected and coordinated with surge arresters and/or surge capacitors. Insulation coordination shall be done keeping in mind the minimum electrical clearances, safety clearances and maintenance clearances as per Switching Impulse Withstand Level (SIWL). Insulation coordination shall be done as per relevant IS/IEC Standards. Insulation levels of oil filled equipment shall be less than other equipment considering its cost.

- (b) The insulation of the equipment and protection levels of Surge Arresters connected to the converter ac bus bars of the converter stations at both rectifiers and inverter shall be coordinated with the insulation and surge arrester characteristics of the connected ac systems to which the converter stations are to be connected without exceeding the discharge duty of these arresters.
- (c) Overvoltages caused by Bipole link HVDC transmission shall be controlled to 1.4 p.u or below. Events caused by other equipment in the A.C. network shall be controlled within the limits of the capability of the deblocked converter. In case the converter is tripped, and not possible to restart within seconds, filter tripping shall be allowed to limit overvoltages.
- (d) The tripping action for lines shall be initiated if the over voltage exceeds 1.1 p.u. for 5 seconds and if 1.5 p.u. voltage persists for more than 100 milliseconds. The HVDC over voltage strategy shall be co-ordinated with such setting.
- (e) The ratio of impulse withstand voltage to impulse protective level shall be in line with IEC-60071-5.
- (f) The minimum insulation levels for 800 kV shall be as follows:

| HV Transformer<br>LIWL/SIWL<br>(kV) | Smoothing reactor<br>LIWL/SIWL (kV) | Thyristor Valve Structure<br>LIWL/SIWL (kV) | DC Busbar<br>LIWL/SIWL (kV) |
|-------------------------------------|-------------------------------------|---|-----------------------------|
| 1800/1600                           | 1800/1600                           | 1800/1600                                   | 1900/1600                   |

LIWL- Lightning Impulse Withstand Voltage;

SIWL- Switching Impulse Withstand Voltage

## 7. Radio Interference (RI), Acoustic Noise (AN) and DC field

- (a) All the necessary precautions shall be made during HVDC design to ensure that there shall be no mal-operation, damage or danger to any equipment, system or personnel due to electromagnetic or electrostatic interference effects. The converter terminal(s) shall neither damage nor cause mal-operation of the DC control and protection system or the DC tele-control system.
- (b) All the necessary precautions shall be taken in the form of noise suppression techniques, shielding and filtering devices to prevent harmful interference, which may be generated by the converter terminals, with the Power line carrier (PLC) systems, Radio communication systems, Television systems, VHF, UHF & microwave radio systems.
- (c) The noise generated by HVDC System shall also be limited by noise reducing measures, if necessary. Noise shall be less than 45 dBA in control room and office areas, 70 dBA at the station boundary and 70 – 90 dBA at various HVDC equipment areas.

## 8. Dynamic Performance:

- (a) The purpose of dynamic performance design is to determine the control parameters for HVDC system and to ensure that the HVDC system shall have smooth, stable and fast operation for both steady state and transient conditions without adversely affecting the connected AC grid.
- (b) The HVDC system shall recover to 90% of the pre-fault dc power transfer level consistently within 120 ms from the instant of fault clearing, without subsequent commutation failure or sustained oscillation for all inverter ac system fault conditions. For all rectifiers ac system fault conditions, the recovery time, to 90% pre- fault power level, shall be within 100 ms from the instant of fault clearing.
- (c) HVDC should continue operation at reduced power if conditions get outside the voltage, frequency and short circuit capacity ranges specified in system data as much as possible with its inherent capability.

**9. Main Circuit Design-**The purpose of Main Circuit design is mainly to determine the operating characteristics and rating of thyristor valves and converter transformers (MVA, tap changer range etc.) It also forms the input for AC Filter and Reactive compensation design. The main circuit arrangement and circuit shall depend on type of HVDC system, Power Transmission requirements, DC Voltage Levels, connected AC voltage levels, Reactive Power requirements and AC & DC Harmonic requirements. The system shall meet various harmonic performance parameters on both AC Side and DC side.

**10. HVDC Station Equipment-** The function blocks of converter station are Converter area (converter valves, converter transformer, Smoothing Reactor), DC yard (DC filters, DCCT, DCVD, PLC filters of DC side, DC pole arresters, Disconnectors and ground switches), AC filter yard, AC yard and auxiliaries. A typical LCC based HVDC station shall consist of the following main equipment:

- (a) Thyristor valves and its accessories e.g. damping and grading circuits, converter cooling system, etc.;
- (b) Converter transformers;
- (c) Smoothing reactors (If required);
- (d) DC filters\*;
- (e) AC filters (Harmonic filters and PLC filters) and shunt compensation;
- (f) Control and protection of AC and DC side;
- (g) Electrical and mechanical auxiliaries;
- (h) Earth electrode station\* / Dedicated Metallic Return (DMR) \*;
- (i) AC switchyard equipment;
- (j) DC switchyard equipment\*;
- (k) AC & DC Surge arresters;
- (l) AC & DC Measuring instruments;
- (m) Communication system between converter stations (Optical#/ PLCC).
- (n) DC wall bushings
- (o) AC wall bushings (if applicable)

- (p) Auxiliary Power System
- (q) Electrical and mechanical auxiliaries
- \* Not applicable for back to back schemes.
- # Main communication shall be through optical.

## 11. Converter Station AC Yard, Transformer yard and valve hall

- (a) **AC commutating bus equipment-** The AC circuit breakers, disconnectors, instrument transformers and other switchyard equipment shall be similar to that of the equipment specified under Regulation 43. The bus rating shall be adopted according to the calculation considering single bus outage. The switching duties of the AC circuit breakers will be decided based on transient over voltage study, insulation co-ordination, AC filters and protection studies.
- (b) **Dynamic over voltage limiter devices-** Converters connected to relatively weak AC systems may cause dynamic over voltages (DOVs) during load rejection / disturbance. The DOV limiter shall consist of parallel arrester elements connected phase to phase or phase to ground and designed to absorb the desired amount of energy during a system disturbance. The DOV limiter shall be coordinated with recovery of DC system following a disturbance. The requirements of surge arresters shall be based on the insulation co-ordination study in line with relevant standards. The arresters used shall be metal oxide (ZnO) type conforming to relevant standard. For control of DOV, use of STATCOM, SVC and high power gapless arresters shall be evaluated.
- (c) **AC harmonic filters and shunt compensation**
  - (i) The HVDC converter generates harmonics during the Conversion process and AC harmonic filters shall be used to limit ac voltage distortion due to harmonics to acceptable levels and also to meet the reactive power exchange requirements based on the studies carried out.
  - (ii) The AC harmonic filters shall be switched in and out by circuit breakers. Based on the studies, the reactive power requirement for the terminal and bank or sub-bank size shall be determined such that reactive power exchange with the AC bus shall remain within specified limits. Suitable redundancy shall be provided in the sub-bank filters to avoid reduction of transmission capacity of the station due to outage of any particular sub-bank for maintenance.
  - (iii) The main filter equipment namely capacitors, reactors and resistors shall comply with the requirements of following IEC
    - (A) Capacitors : IEC 60871;
    - (B) Reactors : IEC 60076-6;
    - (C) Resistors : IEC 62001.
    - (D) .Dynamic compensation: If required, dynamic compensation in the form of static compensator (STATCOM), static var compensator (SVC), thyristor controlled series capacitor (TCSC) etc. shall be used to improve stability during AC system transient faults. The requirement of dynamic compensation and the rating shall be derived from the studies. .

- (iv) **Shunt Reactor Banks:** Shunt reactors of suitable size shall be provided to meet reactive power exchange requirements derived from the studies. The shunt reactor shall be oil filled and must be switched in or out by a circuit breaker. The shunt reactor shall conform to relevant standard. The shunt reactor shall be covered under automatic switching under the reactive power control strategy.
- (v) **AC filter Design:** The Total Harmonic Distortion ( $V_{thd}$ ) of AC filter, as defined below, shall not exceed 2%.

$$V_{THD} = \sqrt{\sum_{n=2}^{n=40} \frac{V_n^2}{V_1^2}} \times 100$$

'1' refers to fundamental frequency (50 Hz)

'n' refers to the harmonic of n<sup>th</sup> order (corresponding frequency is 50 x n Hz)

Additional requirements as per relevant IEC shall also be fulfilled. In all Modes of operation, except the reduced dc line voltage modes, the performance requirement shall be met up to rated power with one larger size filter sub-bank and one characteristic harmonic sub-bank(largest) being out of service. All filter banks, sub-banks and branches shall be rated such that the remaining filter components are not overloaded and there is no restriction on the operating power level for any operating conditions with one filter bank outage for power level up to 1.0pu.

- (d) **Power line carrier (PLC) filtering-** PLC filters shall be installed close to converter transformers to mitigate high frequency harmonic currents generated during thyristor switching.
- (e) **Converter transformers:**
- (i) The converter transformers shall be single phase/ three phase two winding or three winding units which shall be decided by size and transportation limitations. The transformers shall comply with the requirements of relevant standards. The maximum flux density in any part of the core and yoke at the rated MVA, voltage and frequency shall be such that under 10% continuous over voltage condition it does not exceed 1.9 Tesla. The Converter transformer shall be capable of withstanding minimum DC current of 10A per single phase transformer entering through the neutral.
  - (ii) The insulation level for the transformer AC (line side) windings and bushings shall be as given at Regulation 43 and insulation levels of the valve side windings shall be determined in accordance with studies. The impedance of the transformer shall be determined as in accordance with studies and variations in impedance shall be as per the requirement of relevant standards.
  - (iii) Converter transformers shall be equipped with on load tap changer (OLTC) and metal oxide varistor (MOV) devices shall be provided between tap leads of the OLTC. The OLTC tap steps shall be determined in accordance with the operating strategy of both the converters. The OLTC shall be designed for a minimum 2,50,000 operations without



repair or change of any part including oil. The OLTC shall be designed for a contact life of minimum 6,00,000 operations.

- (iv) The requirements of soak pits and firewalls shall be in line with Regulation 43.
  - (v) One No. (single phase or three phase, as applicable) spare Converter transformers of each type and rating per bipole shall be provided in each converter station.
- (f) **Thyristor valves**
- (i) The thyristor valve assembly shall be designed and tested as per relevant IEC/IS.
  - (ii) The thyristor valve modules, used for converting AC to DC or vice versa, shall be complete with associated electronic firing system; protection, monitoring & damping system, auxiliaries and cooling system. Twelve pulse scheme shall be used.
  - (iii) One / Two twelve pulse valve group in series or parallel combination shall be used depending on the power rating and other requirement of specific project.
  - (iv) In case of two series converter configuration, a bypass switch shall be provided to bypass any faulty converter and use the remaining series converter at lower DC voltage.
  - (v) The thyristor valves shall be water cooled, air insulated and indoor type. The valves shall be either suspended type or floor mounted type depending upon the operating DC voltage and seismic requirements. The Double or Quadruple valve design shall be used depending on voltage level. Requisite redundancy shall be kept through a provision of suitable number of spare thyristor in valve modules.
  - (vi) The thyristor valve cooling system shall use de-ionized water circulated in a closed cycle. The cooling unit shall comprise of a de-ionizer, expansion vessel, conductivity, flow and temperature sensors, mechanical filters, etc. Adequate redundancies shall be provided. Necessary control and monitoring including tripping of the HVDC system in case of cooling system failure shall be provided.
  - (vii) The valves shall be placed in the valve hall which shall have a positive pressure over atmospheric pressure and humidity control feature. The pressurization will be maintained by ventilation system.

**12. Converter Station DC Yard**

- (a) The DC yard shall comprise of equipment such as HVDC bushings, smoothing reactors, DC filters, DC current and voltage measuring instruments and switchgear, surge arrester, insulators, clamps and connectors.
- (b) The creepage distance for DC yard and other areas shall be maintained as indicated below:

| Insulator type                | Under light and Medium pollution | Under heavy and very heavy pollution |
|-------------------------------|----------------------------------|--------------------------------------|
| Indoor porcelain or composite | 20 mm/kV                         |                                      |

|   |          |          |
|---|----------|----------|
| insulators for valve hall (other than valves) and indoor smoothing reactor area |          |          |
| Thyristor Valves  | 14 mm/kV |          |
| Indoor DC yard (other than smoothing reactor)                                   | 30 mm/kV |          |
| Outdoor porcelain insulators or bushings with RTV coating                       | 50 mm/kV | 60 mm/kV |
| Outdoor composite insulators or bushings  | 50 mm/kV |          |

**Note:- Creepage distances less than 50 mm/kV but not less than 45mm/kV can be accepted for outdoor silicone rubber bushings due to manufacturing limitations and for HVDC equipment's requiring necessary internal/ external insulation co-ordination. However, creepage distance less than 50 mm/ kV and flash distance less than 12 mm/ kV shall not be acceptable for outdoor jointed bushing.**

The base voltage applicable for calculation of valve arrester creepage distance shall be

$$U_{creepage} = \left( \sqrt{\frac{1}{3} + \frac{\sqrt{3}}{8\pi}} \right) * CCOV$$

(c) **DC wall bushing-** DC wall bushings, used for electrical connection between the equipment inside the valve hall and the outdoor DC yard shall be of polymer housing as per relevant standards. All bushings inside the valve hall including HVDC wall bushing shall be dry type / SF6 gas filled or combination of both.

(d) **Smoothing Reactor-** The smoothing reactor shall be of air core type. The reactors shall comply with relevant standards and shall have successfully passed DC tests as per their application. The smoothing reactor shall be divided between pole and neutral for DC voltage above 500kV. Each converter station shall be provided with one spare coil of smoothing reactor. For the design of smoothing reactor, the **Si factor** has to be within the limits (0.22 < Si < 1) where Si factor is defined as

$$Si = U_{dn} / L_d * I_{dn}$$

U<sub>dn</sub> = Nominal HVDC Voltage level per pole

I<sub>dn</sub> = Nominal HVDC Current

L<sub>d</sub> = Total DC side inductance = L<sub>dr</sub> + 3.5 L<sub>tr</sub> where L<sub>dr</sub>- Smoothing Reactor inductance

L<sub>tr</sub>- Converter transformer inductance

The smoothing reactor shall be designed for Class H for inter turn insulation as per IEC 60085, however, the maximum allowed hot-spot temperature rise shall be limited to one class lower i.e. Class F insulation.

(e) **DC Voltage and Current Measuring Devices-** The DC voltage **measuring** equipment shall be installed at each pole. The DC measuring equipment at pole and neutral bus shall be suitably located based on the control philosophy and different protection zones such that complete pole and neutral equipment are protected.

(f) **DC Filters-** DC harmonic filters shall be provided in DC yard to limit harmonic voltages present on the DC lines (pole lines and electrode lines / DMR line). The DC Filters shall consist of Blocking Filter, Low order filters, Harmonic Filters and High Frequency Filters as per the requirement of project specific studies. The main filter equipment like capacitors, reactors and resistors shall comply with the requirements of relevant IS/IEC standards/ CIGRE documents. A series blocking filter shall be provided, if required based on system studies, at each converter of the inverter station. A parallel low order (2<sup>nd</sup> Harmonic) DC Filter shall be provided across each converter of the station.

(g) **DC Filter Design-** The individual harmonic current (In) at any harmonic shall not exceed the value which could cause mal-operation of the HVDC system control and protection equipment supplied.

The maximum equivalent disturbing current (I<sub>eq</sub>), without any filter outage, for balanced bipolar and monopolar mode with metallic return or Dedicated Metallic Return (DMR) modes of operation shall be as follows:

| Operating Mode                           | I <sub>eq</sub> |
|--|-----------------|
| Balanced bipolar operation               | 1500 mA         |
| Monopolar mode with metallic or DMR mode | 2200 mA         |

The DC filter components shall be adequately rated to allow unrestricted operation of the HVDC system in all operating modes and for all power levels upto 1 p.u with any possible combination of filter branches connected.

The rating of the dc filter components shall be based on the assumption that the per pole harmonic voltage is individually maximized at each harmonic for any particular operating mode, and the filter component currents due to the harmonic voltages at the terminals shall be assumed to add as RSS (Root sum squared) at each harmonic.

Blocking filter reactor shall be designed for Class H for inter turn insulation as per IEC 60085, however, the maximum allowed hot-spot temperature rise shall be limited to one class lower i.e Class F insulation. The AC/DC/PLC/RI reactor shall be designed for Class F insulation as per IEC 60085, however, the maximum allowed hot-spot temperature rise shall be limited to one class lower i.e. Class B insulation.

(h) **Surge Arresters**

Surge arresters shall be gapless Metal Oxide arresters and shall be designed, and tested as per relevant IS / IEC. The arresters shall be designed to absorb the desired amount of energy during a system disturbance and shall be coordinated with recovery of DC system following a disturbance as applicable.

The HVDC main arresters typically found in a HVDC System are as follows:

- (i) Valve Arrester
- (ii) Bridge Arrester (6 pulse/12 pulse)
- (iii) DC Line Arrester
- (iv) DC Neutral and DC Filter Arrester
- (v) Converter Transformer and AC Filter Bus Arrester
- (vi) Electrode line arrester / DMR line arresters
- (vii) Smoothing Reactor Arrester
- (viii) DC Neutral Switch Arresters

### **13. Control and Protection System**

#### **(a) Control System:**

- i) The control system shall have redundancy with hot standby.
- ii) DC converter terminals shall be either manned by operator or controlled by remote operation of SCADA system. The control system hierarchy shall be as follows:
  - (A) Station/Bipole Control
  - (B) Pole/ Converter Control
  - (C) Valve control
- iii) The HVDC Bipole shall have control features including but not limited to the following:
  - (A) Reactive power controller
  - (B) Current and power controller
  - (C) Frequency controller
  - (D) Power modulator, pole power compensation The modulator shall have feature which shall provide positive damping of ac network oscillations over the range of frequencies considered during system studies.
  - (E) Sub Synchronous Resonance (SSR) Damping Controller (if required)

All necessary studies shall be carried out to ensure that the DC system shall not excite the mechanical, electromechanical or other natural frequencies of the nearby region generators and turbines under any operating mode. It shall be demonstrated by studies (simulation as well as field test) that the nearby generators shall not be adversely affected by the HVDC system, particularly with regard to Sub Synchronous Oscillation (SSO) / Sub Synchronous Resonance (SSR) and harmonic injection and

self-excitation. Sub Synchronous Damping (SSD) Controller shall be provided for converter Stations near Generating stations.

- (A) Load frequency controller (LFC)
- (B) Current margin controller
- (C) Excessive reactive power consumption controller
- (D) AC system stability function, such as power swing damping function.
- (E) Run back / Run up controller with provision to be linked to SPS of System Operator

iv) The pole control, converter control, and valve control modules shall also be provided.

v) The control shall be designed to give fast stable and proper response to normal control actions as well as during disturbances such as AC & DC faults.

**(b) Protection System**

i) HVDC system protection shall consist of two parts:

(A) AC side protection:

AC side protection function shall cover the zone for converter transformer, AC filters, shunt capacitors, shunt reactors, and busbars. These protections shall generally follow the same philosophy as in a typical substation i.e. detection of fault by relay and tripping of circuit breaker.

(B) DC side protection:

DC side protection shall cover the zones consisting of the valve hall, DC switchyard including smoothing reactor and DC filters, DC line, DMR line / electrode line and ground electrode. The protection equipment shall be designed to be fail safe and shall ensure high security to avoid mal-operation/ unwanted shutdown due to protection equipment failures.

ii) Following a DC Line fault, the HVDC System shall have the facility to restart, one or more times, the faulted pole at a variable pre-selected DC voltage level(s), not below 80% of the nominal voltage rating. The dc transmission system shall be capable of recovery in a controlled and stable manner without commutation failures during recovery following ac and dc system faults. The post fault power order shall be equal to the pre-fault power order unless AC/ DC systems dictate otherwise

iii) Protection system shall have two redundant systems with following protections.

- (A) Converter differential protection;
- (B) DC over current protection;
- (C) DC differential protection;
- (D) AC conductor ground fault protection;
- (E) Commutation failure protection;

- (F) DC filter protection (not applicable for back to back schemes);
- (G) DC smoothing reactor protection;
- (H) DC line ground fault protection with restarts;
- (I) DC line differential protection;
- (J) DC under voltage/ over voltage protection;
- (K) Ground Return mode / Dedicated Metallic Return (DMR) protection
- (L) AC filter protections
- (M) Electrode line monitoring and protection
- (N) Thyristor Failure Monitoring

iv) DC online fault locators shall be provided to monitor the entire DC line length and give location of the fault with good accuracy in the range of  $\pm 1000$  meters

(c) Software based controls and protection shall be used to permit flexibility in effecting modifications at a later date. Protection and controls shall be duplicated for reliability. The control & protection shall provide fast controllability of the HVDC system. Operation of the HVDC bipole system shall be possible in the following modes:

- i) Balanced/ unbalanced bipolar operation;
- ii) Monopolar operation with pole metallic return;
- iii) Monopolar operation with ground return / with Dedicated Metallic Return (DMR) mode;
- iv) Reduced voltage operation;
- v) Power reversal mode.

(d) The 'Sequence of events' recorder, transient fault recorder, on-line DC Line fault locator, GPS system, visual display system, operator control protection and monitoring system shall be a part of the HVDC system.

**14. Telecommunication-** For smooth operation of the HVDC system, communication network with high reliability and availability shall be provided for transmission of control and protection signals between the two or more (in case of multi-terminal DC) HVDC terminals. There shall be main and back up communication link. The main communication link shall be through OPGW and back up communication link shall be either through OPGW or PLCC.

**15. Valve Hall:** The valve hall shall mainly contain thyristor valves, its associated structure, & cooling and arresters. No oil filled equipment shall be present inside the valve hall. In case the turret of converter transformers (having oil) is protruding inside the valve hall, suitable fire barrier matching with adjacent valve hall wall fire rating shall be provided. The valve halls shall be provided with interference screening. In addition, the control cable and cable termination rooms shall be suitably screened to minimize radio interference. Two nos. scissor lift for erection and maintenance of valve modules shall be provided per station. Proper cable sealing shall be provided for cable entry into valve hall and

control room to avoid entry of water and moisture. Necessary measures shall be taken to take care of high frequency noise emission from valves.

**16. Valve Hall Ventilation:** Suitable ventilation systems and filters with adequate redundancy shall be provided in the valve hall. The valve hall shall be kept at a positive pressure under all conditions.

### **17. Grounding & Safety**

- (a) The design of the grounding system shall be based on relevant IS/ IEEE.
- (b) In order to prevent adverse effect (overheating due to induced circulating current) of magnetic field of air core reactors, special care shall be taken such that no closed loops are formed by the earthing conductors and in reinforcement bars of the foundation. Air core reactor manufacturer's guidelines shall be followed.
- (c) The electrical safety clearances for the dc side shall not be less than the clearances applicable for an ac switchyard at the equivalent BIL level.
- (d) The total electric field excluding space charge at ground level shall be as prescribed in relevant standards.
- (e) Fencing and electrical & mechanical key interlocking arrangements shall be provided for all accessible areas and for valve halls, smoothing reactor area, AC and DC filter areas.

### **18. Dedicated Metallic Return (DMR) / Earth Electrode**

The current return path of a bipolar configuration shall be either via a Dedicated Metallic Return (DMR) conductor or via earth return using earth electrodes at both converter terminals. DMR mode shall be preferred if it is difficult to identify a suitable site for earth electrode station.

If earth electrodes are to be used the following requirements shall also be considered:

- (a) The earth electrode station shall be connected to the terminal by means of an overhead transmission line. The earth electrode shall be located at a minimum distance of approximately 25 km (radial distance) away from the converter station. It shall be designed to operate continuously at nominal load and overload as per the requirement. The electrodes shall be designed for both types of operation, anodic and cathodic.
- (b) The thorough soil investigation shall be carried out for shallow and deep resistivity, thermal conductivity and moisture content etc. at the proposed location.
- (c) The earth electrode station shall have sub-electrodes. The maximum current density at the sub-electrode surface, i.e. the boundary between backfill (coke) and soil shall not exceed 0.5 A/m<sup>2</sup> in clay soils. The number of sub-electrodes shall be determined considering that 30% of the sub-electrodes are not available. The amp hour rating for earth electrode shall be selected based on the study for duration of earth electrode current and the service life of the earth electrode station.

- (d) The earth electrode station shall not affect the nearby electrical installation, buried metallic pipelines, oil & gas pipelines, and railway lines etc.
- (e) Each ground electrode shall have a resistance of less than or equal to 0.3 ohm (both working as an anode and cathode) at maximum design ambient temperature.
- (f) Touch voltage ( $V_t$ )- The touch voltage between any grounded metallic object in the electrode station (including the connection to the overhead electrode line) and any point in the soil which can be touched by a person simultaneously shall not exceed 40 V when the electrode is operating at the maximum overload rating.
- (g) Step Voltage ( $V_s$ )- The step voltage at ground level above the ground electrode when the electrode is operating at the temporary over-toad rating shall not exceed  $(V_s) = 5.0 + 0.03 \rho_s$ , where  $\rho_s$  is the local surface resistivity in ohm-m.
- (h) The above values of resistance: touch and step voltages would depend on the actual geophysical
- (i) characteristics of the soil at the place where the electrode station is located. Suitable mitigation measures shall have to be adopted in case the site has high resistivity.
- (j) In addition, following interference effects shall be considered.
  - (i) Corrosion of buried metallic structure and foundations
  - (ii) DC Current in power lines, especially via power transformer neutrals (risk of saturation of transformers).
  - (iii) DC current in telephone circuits.
  - (iv) Effect on the cathodic protection of the buried metallic pipe lines.

**19. Cables:** Fibre optic cables conforming to IEC – 60793 shall be used to transmit the signals to and from various equipments and panels located in the AC/DC switchyards, Valve Halls, control rooms, valve cooling rooms, etc.

**20. Auxiliary Power Supply System:** The auxiliary power supply system shall have the following:

- (a) Highly reliable duplicated supply sources from two separate sources, with automatic change-over facilities.
- (b) Completely separated secondary distribution (415V) systems for the auxiliaries of each converter.
- (c) Duplicated supply by two different 415V power sources to essential loads (e.g. cooling pumps, fans, heat exchangers, etc.).
- (d) Provision of reliable standby power supply system to meet essential and emergency loads and which starts-up automatically in case of loss of all the normal and standby supply sources. One reliable standby power supply system per converter shall be provided at all the converter stations.
- (e) Parallel operation between station service transformers shall not be permitted at any voltage level in order to limit fault currents, prevent back feed into the AC bus and to ensure independence of supply sources. Also parallel operation shall not be permitted between transformers and the reliable standby power supply system.
- (f) Suitable protection on all primary MV and LV supply connections



- (g) All auxiliaries shall give rated output at voltage variation of  $\pm 10\%$  and frequency variation of  $-5\%$  to  $+3\%$ .
- (h) The station services DC system shall cater to the following:
  - (i) DC loads of HVAC and HVDC switchyards, auxiliary services control, valve and pole control, protection circuits, communication system loads, etc.
  - (ii) An indispensable minimum lighting load shall be connected to the station DC system.
- (i) The 220VDC supply system(s) per converter shall consist of at least two independent DC systems; each system consisting of one charger, one battery bank and one distribution panel.
- (j) A 48 V DC system consisting of two battery sets, two Battery chargers and two distribution boards shall also be supplied for communication panels (wherever supplied).

**21. Fire Detection, Alarm and Protection system:** A comprehensive fire detection, alarm and protection system as per Regulation 43 shall be provided. Valve Hall shall have Air aspiration system (fast and early smoke detection system) Suitable Infra-Red (IR) detector to detect the flashover inside the Valve Hall shall also be provided. The Valve hall wall shall be suitable for minimum 3 hour fire rating.

**22. Testing and trial Operation:** All equipment / component including Thyristor valves, Converter Transformers, smoothing reactors, EHV DC Transformer bushings and wall bushings shall be subjected to Type tests, Routine tests, Factory Acceptance Test (FAT), Site Acceptance Test (SAT) as per relevant IS / IEC/ IEEE as applicable. The SAT shall consist of sub-system & system tests and shall be carried out after installation of equipment at site. The subsystem tests cover the major sub-system like valve cooling, AC&DC filters, HVDC converter, auxiliary systems, communication etc. After completion of sub-system tests, system tests covering power transmission tests, transient & dynamic control tests, measurement of electric field and RFI etc. shall be conducted. After completion of all system tests, final trial operation of the HVDC System shall be carried out for uninterrupted continuous period of normal operation of not less than 10 days during which the converter equipment shall be fully operational.

**23. Performance Guarantee:**

- (a) The power Transmission Capacity:  
The rated power transmission capacity shall be defined and guaranteed at inverter end of AC yard and rated transmission voltage shall be defined at the rectifier end. The reverse Power transmission capacity shall also be indicated.
- (b) HVDC System losses:  
The Guaranteed losses of HVDC transmission shall include the no load loss and equivalent load loss. The equivalent load loss is the sum of load losses at specific loadings multiplied by weightage factors as per expected loading cycle. The Guaranteed losses shall be verified as per

IEC 61803. No load loss shall be guaranteed corresponding to converter transformer set at principal tap with nominal AC system voltage and nominal frequency at 40° C ambient temperature.

(c) The system shall meet various harmonic performance parameters on both AC Side and DC side.

(d) HVDC Reliability and Availability:

|   |  |   |
|---|--|---|
| 1 | Overall Energy availability of HVDC scheme<br><br>(a) Overall Performance<br>(b) Excluding transformer failure | Not less than 97%<br>Not less than 98%                      |
| 2 | Forced Energy Unavailability (FEU)   | Not more than 0.6%  |
| 3 | Schedule Energy Unavailability (SEU)   | Not more than 1%  |
| 4 | Single Pole outage per pole per station per year   | Not more than 8 (with average outage duration of 7.5 hours) |
| 5 | Bipole outage per station per year   | Not more than 0.2 (with average outage duration of 8 hours) |

**24. Applicable Standards:** All equipment and material shall be designed, manufactured, tested and commissioned in accordance with latest Indian Standards / IEC or IEEE standards, / CIGRE guidelines and the Acts, Rules, Laws and Regulations of India. Some of them are as follows:

- (a) IEC 60633 - Terminology for High-Voltage Direct Current (HVDC) transmission
- (b) IEC 60700 (1-2) - Thyristor valves for High Voltage Direct Current (HVDC) power transmission
- (c) IEC 60919 (1-3) - Performance of High-Voltage Direct Current (HVDC) systems with line-commutated converters
- (d) IEC 61803 - Determination of power losses in High-Voltage Direct Current (HVDC) converter stations with line-commutated converters
- (e) IEC-61975 - High-Voltage Direct Current (HVDC) installations - System tests
- (f) IEC-62001 (1-4) - High-Voltage Direct Current (HVDC) systems - Guidance to the specification and design evaluation of AC filters
- (g) IEC 65700 – Bushings for DC Applications
- (h) IEC 60071 (1- 5) – Insulation Coordination
- (i) CIGRE report 33/14-05: “Application guide for metal oxide arresters without gaps for HVDC converter stations”
- (j) IEC 61378 - Converter transformers
- (k) IEC – 600076-6 Power transformers - Part 6: Reactors
- (l) IEC 60871-(1-4) Shunt capacitors for a.c. power systems having a rated voltage above 1000 V

- (m) IEC 60747-6 - Semiconductor devices - Part 6: Discrete devices – Thyristors
- (n) CIGRE- TB 136 1999 SC 14 TF 14.01.04 Fire aspects of HVDC thyristor valves and valve halls.
- (o) PWI/TR 115-6 Ed. 1.0 -Guidelines for the system design of HVDC project
- (p) IEC/TS 63014 Ed. 1.0 -High voltage direct current (HVDC) power transmission - System requirements for dc-side equipment - Part 1: Line-Commutated Converters
- (q) IEC/TR 63065 Ed. 1.0 - Guidelines for operation and maintenance of HVDC converter station
- (r) IEC/TR 62978 Ed. 1.0 -Guidelines on Asset Management for HVDC Installations
- (s) IEC/IEEE:60076-57-129 – Transformer for HVDC applications
- (t) IEC60099-9-Part -9, Surge Arresters – Metal Oxide Surge Arresters without gaps for HVDC converter stations

## Part-B

### Technical Details of Voltage Source Converter (VSC)based HVDC Terminals/ Stations

1. **General:** The VSC based HVDC system shall use Insulated Gate Bipolar Transistor (IGBT) technology and shall be considered primarily for the following without concerns about the available Short Circuit Ratio:
  - Point to point transmission scheme (overhead / cable)
  - Back to Back transmission scheme
  - Parallel operation with LCC HVDC system
  - Multi-terminal system
  - Supplying load in isolated areas
  
2. **Design Consideration:** The following minimum technical information shall be required for VSC based HVDC installation:
  - (a) The amount of active power to be transmitted
  - (b) The reactive power requirement at each terminal for dynamic support of AC network
  - (c) The transmission distance and type of DC transmission line (cable or overhead line or a combination thereof)
  - (d) Length of overhead line, length of cable as applicable
  - (e) DC transmission voltage
  - (f) Reliability and availability requirement
  - (g) Size and weight of the Converter transformers for transport
  - (h) Power system characteristics of sending and receiving end system to which VSC transmission system is connected, including all the parallel transmission system, if any
  - (i) Steady State performance requirements
  - (j) Dynamic performance requirements, including control and monitoring facilities
  - (k) Transient performance
  
3. **System Data:** The following environmental, AC & DC system information, shall be considered:
  - (a) Environmental information:
    - (i) Ambient temperature
    - (ii) Humidity, rain fall intensity
    - (iii) Geographical co-ordinates
    - (iv) Isokeraunic level
    - (v) Wind velocity
    - (vi) Seismic Level
    - (vii) Altitude above sea level
    - (viii) Pollution level
    - (ix) Soil Properties

- (b) AC System information:
  - (i) Short Circuit Ratio and Minimum & Maximum Short Circuit Current:
  - (ii) System voltage and frequency
  - (iii) Harmonic impedance characteristics
  - (iv) System Voltage distortion
  - (v) System Grounding
  - (vi) Torsional mode frequencies (Sub-synchronous Resonance)
  - (vii) AC system topology
  - (viii) AC system equivalent
  - (ix) MVAR exchange with AC system
  
- (c) HVDC line / Cable:
  - I. In case of overhead lines, the detail information shall include
    - (i) Line length
    - (ii) Conductor type
    - (iii) Conductor configuration
    - (iv) Rated DC Voltage
    - (v) Impulse withstand levels
    - (vi) Tower configuration for the Pole conductors & Dedicated Metallic Return (DMR) conductor or earth electrode
    - (vii) Tower footing impedance
    - (viii) Earth electrode station (if applicable)
  
  - II. In case of Cable, the detail information shall include
    - (i) Cable length
    - (ii) Cable size and insulation
    - (iii) Rated and maximum DC voltage
    - (iv) Current rating
    - (v) Capacitance and resistance at rated load
    - (vi) Impulse withstand levels
  
- 4. System Studies:** HVDC control parameters and equipments shall be designed by carrying out the following studies at different stages of the project:
  - a) Design Studies
    - (i) Main Circuit Parameter
    - (ii) AC Over-Voltage [DOV, Temporary Over Voltage and Transient Over Voltage]
    - (iii) DC Over-voltage
    - (iv) Low Frequency Characteristics
    - (v) High Frequency Characteristics
    - (vi) Transient Stresses
    - (vii) External Insulation and Clearances
    - (viii) Insulation co-ordination
    - (ix) AC Circuit Breaker Requirements

- (x) Equipment design studies
  - (xi) Station Earthing
  - (xii) Lightning Protection
- b) Performance Studies
- (i) Losses
  - (ii) Electrical Interference
  - (iii) Electric and Magnetic Fields
  - (iv) Reliability, Availability and Maintainability
  - (v) Audible Noise
- c) Network Studies
- (i) Stability, Modulation and Frequency Control
  - (ii) AC System Equivalents
  - (iii) Sub-Synchronous Torsional Interaction
  - (iv) Black start islanded operation studies

**5. HVDC Station Equipment-** A typical HVDC station shall consist of the following main equipment:

- a) VSC valves and associated equipment & cooling system
- b) Interface transformers;
- c) Converter reactors;
- d) DC reactors\*;
- e) Phase reactor\*
- f) DC filters\*;
- g) AC filters\*;
- h) Radio frequency interference filters\*
- i) Valve side harmonic filters\*
- j) Control and protection of AC and DC side;
- k) Electrical and mechanical auxiliaries;
- l) Earth electrode station\*;
- m) AC switchyard equipment;
- n) DC switchyard equipment;
- o) AC and DC Surge arresters;
- p) AC and DC Measuring instruments;
- q) Communication system between converter stations (Optical/ PLCC).

- r) Wall bushings (AD and DC side)
- s) Insertion resistors
- t) High Impedance Grounding of Symmetrical Monopoles

\* if applicable

## 6. Converter Station AC Yard, Transformer yard and Valve Hall

- (a) **AC bus equipment-** The AC circuit breakers, disconnectors, instrument transformers and other switchyard equipment shall be similar to that of the equipment specified under Regulation 43. The bus rating shall be adopted according to the calculation considering single bus outage. The switching duties of the AC circuit breakers will be decided based on transient overvoltage study, insulation co-ordination, AC filters (if applicable) and protection studies.
- (b) **Insertion resistors-** Insertion resistors shall be used to limit inrush currents during energization of the converter. They shall be located on the primary or converter side of the interface transformer. After the energization process is completed the resistor shall be bypassed by a disconnector or bypass switch.
- (c) **AC harmonic filters (If required)**
  - (i) State-of-the-art Voltage-Sourced Converters (VSC) in modular multi-level converter (MMC) topologies generate nearly no or only a small amount of harmonics. The need of ac harmonic filters shall be evaluated based on study results. Suitable redundancy shall be provided in the filters to avoid reduction of transmission capacity of the station due to outage of any particular sub-bank for maintenance.
  - (ii) If filters are required, the main filter equipment namely capacitors, reactors and resistors shall comply with the requirements of following IEC or Equivalent IS as follows:
    - Capacitors : IEC60871;
    - Reactors : IEC 600766;
    - Resistors : IEC 62001.
- (d) If study results confirm the need for power line carrier (PLC) filtering, PLC filters shall be installed close to interface transformers to mitigate high frequency harmonic currents generated during IGBT switching.
- (e) **Interface transformers**
  - (i) The interface transformers shall be single phase units. For smaller HVDC ratings (e.g. back-to-back schemes) three phase

transformers can be used. The transformers shall comply with the requirements of relevant standards. The maximum flux density in any part of the core and yoke at the rated MVA, voltage and frequency shall be such that under 10% continuous overvoltage condition it does not exceed 1.9 Tesla.

- (ii) The insulation level for the transformer AC (line side) windings and bushings shall be as given at Regulation 43 and insulation levels of the valve side windings shall be determined in accordance with studies. The impedance of the transformer shall be determined in accordance with studies and variations in impedance shall be as per requirements of relevant standards.
- (iii) Interface transformers shall be equipped with On Load Tap Changer (OLTC) mechanism, Metal Oxide Varistor (MOV) devices (if applicable) shall be provided between tap leads of the OLTC. The OLTC tap steps shall be determined in accordance with the operating strategy of the converters.
- (iv) The requirements of soak pits and fire walls shall be in line with Regulation 43.

(f) **VSC valves**

- (i) The IGBT valves shall be complete with associated auxiliaries and cooling system. The VSC valves shall be tested as per IEC 62501. Adequate redundant devices shall be provided to enable continued operation in case of failure of an individual component. Advanced converter topologies shall be used to reduce losses of VSC based HVDC converters.
- (ii) The VSC valves shall be water cooled, air insulated and indoor type. The valves shall be either suspended type or floor mounted type depending upon the operating DC voltage and seismic requirements.
- (iii) The VSC valve cooling system shall use de-ionized water circulated in a closed cycle. The cooling unit shall comprise of a de-ionizer, expansion vessel, conductivity, flow and temperature sensors, mechanical filters, etc. Adequate redundancies shall be provided. Necessary control and monitoring including tripping of the HVDC system in case of cooling system failure shall be provided. In case of Sub-Zero Temperature prevailing at site, suitable method e.g. use of anti-freezing medium etc. shall be adopted.
- (iv) The valves shall be placed in the valve hall which shall have a positive pressure over atmospheric pressure and humidity control



through HV AC system.

## 7. Converter Station DC Yard

- (a) The DC yard shall comprise of equipment such as HVDC bushings, DC reactors, DC filters (if applicable), DC current and voltage measuring instruments and switchgear.
- (b) The creepage distance for DC yard and other areas shall be maintained as indicated below:

| Insulator type  | Under light and medium pollution | Under heavy and very heavy pollution |
|---|----------------------------------|--------------------------------------|
| Indoor porcelain or composite insulators for valve hall (other than valves) and indoor smoothing reactor area (if applicable) | 20 mm/kV                         | 20 mm/kV                             |
| IGBT Valves   | 14mm/kV                          | 14mm/kV                              |
| Indoor DC yard (other than smoothing reactor)   | NA                               | 30 mm/kV                             |
| Outdoor porcelain insulators or bushings with RTV coating   | 50 mm/kV                         | 60 mm/kV                             |
| Outdoor composite insulators or bushings  | 50 mm/kV                         | 50 mm/kV                             |

Note: The silicone content in RTV coating shall be minimum 30%

- (c) **DC wall bushing** - DC wall bushings, used for electrical connection between the equipment inside the valve hall and the outdoor DC yard shall be of polymer housing as per relevant standards.
- (d) **DC Reactors** – The DC reactors (if used) shall be of air core type. The reactors shall generally comply with relevant standards and shall also have been subjected to DC tests as per their application.
- (e) **DC Voltage and Current Measuring Devices**-The DC voltage measuring equipment shall be installed at each pole. The DC measuring equipment at pole and neutral bus shall be suitably located based on the control philosophy and different protection zones such that complete pole and neutral equipment are protected.

- (f) **DC Filters-** If required DC harmonic filters shall be provided in DC yard to limit harmonic voltages present on the DC lines (pole lines and electrode lines).

## 8. Control and Protection

### (a) Control

- i) DC converter terminals shall be either manned by operator or controlled by remote Operation of SCADA system. The control system hierarchy shall be as follows:
  - (A) Station/ Bipole\* Control (\*only for bipolar arrangements, functionality offered as part of station control also acceptable);
  - (B) Converter / Pole Control;
  - (C) MMC control;
  
- ii) The HVDC converter shall have control features including but not limited to the following:
  - (A) Active power control
  - (B) Reactive power control;
  - (C) AC Voltage control
  - (D) DC Voltage control
  - (E) Frequency controller (if applicable);
  - (F) Power modulation control (if applicable);
  - (G) Runback and run-up functions (if applicable);
  - (H) Power Oscillation Damping (POD)
  - (I) Sub synchronous torsional interaction damping control (if applicable);

### (b) Protection

- i) The protection equipment shall be designed to be fail-safe and shall ensure high security to avoid mal-operation/ unwanted shutdown due to protection equipment failures.
  
- ii) HVDC system protection shall consist of following protection zones:
  - (A) AC System Protection zone
  - (B) Converter or Interface Transformer Protection Zone
  - (C) Secondary Busbar Protection Zone
  - (D) Converter Protection Zone
  - (E) DC Busbar Protection Zone
  - (F) DC line & cable Protection Zone
  
- iii) Protection system shall have two redundant systems including the following protections.
  - (A) AC over- and under-voltage protection
  - (B) Over- and under-frequency protection

- (C) AC busbar differential protection;
  - (D) Insertion resistor overload protection
  - (E) AC overcurrent protection
  - (F) Converter overcurrent protection
  - (G) Converter overload protection
  - (H) Converter module differential protection
  - (I) Converter current differential protection
  - (J) DC voltage imbalance protection
  - (K) DC busbar differential protection
  - (L) DC line differential protection
  - (M) DC over- and under-voltage protection
  - (N) Electrode line monitoring and protection (if applicable)
  - (O) DC filter protection (if applicable)
  - (P) AC filter protection (if applicable)
  - (Q) AC connection Harmonic protection
  - (R) Phase current unbalance
  - (S) Protection Block Failure or Repetitive Blocking failure protection
  - (T) Converter arm harmonic protection
  - (U) DC Line + cable Overcurrent Protection
  - (V) DC Line + cable harmonic protection
- (c) Software based controls and protection shall be used to permit flexibility in effecting modifications at a later date. Protection and controls shall be duplicated for reliability. Protection shall be provided by numerical relays to suit the requirement of the HVDC system.
- (d) For bipolar schemes the following operation modes shall be possible:
- i) Balanced/ unbalanced bipolar operation;
  - ii) Monopolar operation with metallic return;
  - iii) Monopolar operation with ground return / DMR
- (e) The 'Sequence of events' recorder, transient fault recorder, on-line DC Line fault locator, GPS system, visual display system, operator control

protection and monitoring system shall be a part of the HVDC system.

- 9. Telecommunication-**For smooth operation of the HVDC system, communication network with high reliability and availability shall be provided for transmission of control and protection signals between the two or more (in case of multi-terminal DC) HVDC terminals. There shall be main and back up communication link. The main communication link shall be through OPGW and back up communication link shall be either through OPGW or PLCC.

#### **10. Grounding & Safety**

- (a) The design of the grounding system shall be based on relevant IS/ IEEE.
- (b) In order to prevent adverse effect (overheating due to induced circulating current) of magnetic field of air core reactors, special care shall be taken such that no closed loops are formed by the earthing conductors and in reinforcement bars of the foundation. Air core reactor manufacturer's guidelines shall be followed.
- (c) The electrical safety clearances for the dc side shall not be less than the clearances applicable for an ac switchyard at the equivalent BIL level.
- (d) The total electric field excluding space charge at ground level shall be as prescribed in relevant standards.
- (e) Fencing and electrical & mechanical key interlocking arrangements shall be provided for all accessible areas and for valve halls, smoothing reactor area, AC and DC filter areas.

- 11. Dedicated Metallic Return (DMR) or Earth Electrode** –The current return path of a bipolar configuration shall be either via a Dedicated Metallic Return (DMR) conductor or via earth return using earth electrodes at both converter terminals. DMR mode shall be preferred if it is difficult to identify a suitable site for earth electrode station. If earth electrodes are to be used the following requirements shall also be considered:

- (a) The earth electrode station shall be connected to the terminal by means of an overhead transmission line or underground cable. The earth electrode shall be located at a minimum distance of approximately 25 km (radial distance) away from the converter station. It shall be designed to operate continuously at full load as per the requirement. The electrodes shall be designed for both types of operation, anodic and cathodic.
- (b) The thorough soil investigation shall be carried out for shallow & deep resistivity, thermal conductivity and moisture content etc. at the proposed location.
- (c) The earth electrode station shall have sub-electrodes. The maximum current density at the sub-electrode surface, i.e. the boundary between backfill (coke) and soil shall not exceed 0.5 A/m<sup>2</sup> in clay soils. The number of sub-electrodes shall be determined considering that 30% of the sub-electrodes are not available. The amp hour rating for earth electrode shall be selected based on the study for duration of earth electrode current and the service life of the earth electrode station.
- (d) The earth electrode station shall not affect the nearby electrical installation, buried metallic pipelines, oil & gas pipelines, and railway lines etc.

- (e) Each ground electrode shall have a resistance of less than or equal to 0.3 ohm (both working as an anode and cathode) at maximum design ambient temperature.
- (f) Touch voltage ( $V_t$ )- The touch voltage between any grounded metallic object in the electrode station (including the connection to the overhead electrode line) and any point in the soil which can be touched by a person simultaneously shall not exceed 40 V when the electrode is operating at continuous loading.
- (g) Step Voltage ( $V_s$ )- The step voltage at ground level above the ground electrode when the electrode is operating at the temporary over-toad rating shall not exceed  $(V_s) = 5.0 + 0.03 \rho_s$ , where  $\rho_s$  is the local surface resistivity in ohm-m.
- (h) The above values of resistance: touch and step voltages would depend on the actual geophysical characteristics of the soil at the place where the electrode station is located. Suitable mitigation measures shall have to be adopted in case the site has high resistivity.
- (i) In addition, following interference effects shall be considered.
  - (i) Corrosion of buried metallic structure of foundations
  - (ii) DC Current in power lines, especially via power transformer neutrals (risk of saturation of transformers).
  - (iii) DC current in telephone circuits.
  - (iv) Effect on the cathodic protection of the buried metallic pipe lines.

**12. Cables:** Fibre optic cables conforming to IEC – 60793 shall be used to transmit the signals to and from various equipments and panels located in the AC/DC switchyards, Valve Halls, control rooms, valve cooling rooms, etc.

**13. Auxiliary Power Supply System:** The auxiliary power supply system shall have the following:

- (a) Highly reliable duplicated supply sources from two separate sources, with automatic change-over facilities.
- (b) Completely separated secondary distribution (415V) systems for the auxiliaries of each converter.
- (c) Duplicated supply by two different 415V power sources to essential loads (e.g. cooling pumps, fans, heat exchangers, etc.).
- (d) Provision of reliable standby power supply system to meet essential and emergency loads and which starts-up automatically in case of loss of all the normal and standby supply sources. One reliable standby power supply system per converter shall be provided at all the converter stations.
- (e) Parallel operation between station service transformers shall not be permitted at any voltage level in order to limit fault currents, prevent back feed into the AC bus and to ensure independence of supply sources. Also parallel operation shall not be permitted between transformers and the reliable standby power supply system.
- (f) Suitable protection on all primary MV and LV supply connections
- (g) All auxiliaries shall give rated output at voltage variation of  $\pm 10\%$  and frequency variation of  $-5\%$  to  $+3\%$ .
- (h) The station services DC system shall cater to the following:
  - i) DC loads of HVAC and HVDC switchyards, auxiliary services control, valve and pole control, protection circuits, communication system loads,

etc.

ii) An indispensable minimum lighting load shall be connected to the station DC system.

- (i) The 220V DC supply system(s) per converter shall consist of at least two independent DC systems; each system consisting of one charger, one battery bank and one distribution panel.
- (j) A 48 V DC system consisting of two battery sets, two Battery chargers and two distribution boards shall also be supplied for communication panels (wherever supplied).

**14. Fire Detection, Alarm and Protection system:** A comprehensive fire detection, alarm and protection system as per Regulation 43 shall be provided. Valve Hall shall have Air aspiration system (fast and early smoke detection system). Suitable Infra-Red (IR) detector to detect the flashover inside the Valve Hall shall also be provided. The Valve hall wall shall be suitable for minimum 3 hour fire rating.

**15. Testing and trial Operation:** All equipment / component including Thyristor valves, Converter Transformers, smoothing reactors, EHV DC Transformer bushings and wall bushings shall be subjected to Type tests, Routine tests, Factory Acceptance Test (FAT), Site Acceptance Test (SAT) as per relevant IS / IEC/ IEEE as applicable. The SAT shall consist of sub-system & system tests and shall be carried out after installation of equipment at site. The subsystem tests cover the major sub-system like valve cooling, AC&DC filters, HVDC converter, auxiliary systems, communication etc. After completion of sub-system tests, system tests covering power transmission tests, transient & dynamic control tests, measurement of electric field and RFI etc. shall be conducted. After completion of all system tests, final trial operation of the HVDC System shall be carried out for uninterrupted continuous period of normal operation of not less than 10 days during which the converter equipment shall be fully operational.

**16. Performance Guarantee:**

(a) The power Transmission Capacity:

The rated power transmission capacity shall be defined and guaranteed at inverter end of AC yard and rated transmission voltage shall be defined at the rectifier end. The reverse Power transmission capacity shall also be indicated.

(b) HVDC System losses:

The Guaranteed losses of HVDC transmission shall include the no load loss and equivalent load loss. The equivalent load loss is the sum of load losses at specific loadings multiplied by weightage factors as per expected loading cycle. The Guaranteed losses shall be verified as per IEC 61803. No load loss shall be guaranteed corresponding to converter transformer set at principal tap with nominal AC system voltage and nominal frequency at 40<sup>0</sup> C ambient temperature.

- (c) The system shall meet various harmonic performance parameters on both AC Side and DC side.
- (d) HVDC Reliability and Availability:

|   |  |   |
|---|--|---|
| 1 | Overall Energy availability of HVDC scheme<br><br>(c) Overall Performance<br>(d) Excluding transformer failure | Not less than 97%<br>Not less than 98%                      |
| 2 | Forced Energy Unavailability (FEU)   | Not more than 0.6%  |
| 3 | Schedule Energy Unavailability (SEU)   | Not more than 1%  |
| 4 | Single Pole outage per pole per station per year   | Not more than 8 (with average outage duration of 7.5 hours) |
| 5 | Bipole outage per station per year   | Not more than 0.2 (with average outage duration of 8 hours) |

**17. Applicable Standards:** All equipment and material shall be designed, manufactured, tested and commissioned in accordance with latest Indian Standards / IEC standards, IEEE / CIGRE guidelines and the Acts, Rules, Laws and Regulations of India. Some of them are for guidance purpose as follows:

- (a) IEC 60633 - Terminology for High-Voltage Direct Current (HVDC) transmission
- (b) IEC 62747 - Terminology for Voltage Source Converters for high-voltage direct current (HVDC) transmission
- (c) IEC 61803 - Determination of losses in High-Voltage Direct Current (HVDC) converter stations
- (d) IEC 62751 - Power losses in voltage sourced converter (VSC) valves for high-voltage direct current (HVDC) systems - Part 2: Modular multilevel converters
- (e) IEC 62543 - High Voltage Direct Current (HVDC) Power transmission using Voltage Source Converters (VSC)
- (f) IEC 62501 - Voltage sourced converter (VSC) valves for high-voltage direct current (HVDC) power transmission - Electrical testing
- (g) IEC 60747-9 - Semiconductor devices - Part 9: Discrete devices – Insulated-Gate Bipolar Transistors (IGBTs)
- (h) IEC 61378 (2-3) - Converter transformers
- (i) IEC 600076-6 - Power transformers - Part 6: Reactors
- (j) IEC 60071 (1- 5) – Insulation Coordination





**SCHEDULE- VII**  
(See Regulation 85(3))

**Right-of-way (ROW) for normal route, forest area, urban area, populated area and approach section near substation**

| <b><i>Voltage level</i></b> | <b><i>Configuration</i></b> | <b><i>Conductor type</i></b> | <b><i>Terrain</i></b>                 | <b><i>Design Span</i></b> | <b><i>String Type</i></b>   | <b><i>RoW width in m (for compensation purpose)</i></b> |
|-----------------------------|-----------------------------|------------------------------|---------------------------------------|---------------------------|---|---|
| 765kV<br>D/C                | Vertical                    | ACSR<br>ZEBRA                | Normal route<br>without<br>constraint | 400                       | "I" String  | 67  |
|                             |                             |                              |                                       |                           | "V" String  |   |
|                             |                             |                              |                                       |                           | Tension   |   |
|                             |                             |                              | Forest                                | 300                       | "V" String  | 56  |
|                             |                             |                              |                                       |                           | Tension   |   |
|                             |                             |                              |                                       |                           | Urban area /<br>populated area /<br>approach section<br>near substation |   |
| Tension                     |                             |                              |                                       |                           |   |   |
|                             |                             |                              |                                       |                           |   |   |
| 765kV<br>S/C                | Vertical /Delta             | ACSR<br>BERSIMIS             | Normal route<br>without<br>constraint | 400                       | "I" String  | 64  |
|                             |                             |                              |                                       |                           | "V" String  |   |
|                             |                             |                              | Forest                                | 300                       | "V" String  | 54  |
|                             |                             |                              |                                       |                           | Tension   |   |

|                |            |                  |  |     |                       |           |
|----------------|------------|------------------|--|-----|-----------------------|-----------|
|                |            |                  | Urban area / populated area / approach section near substation | 250 | "V" String<br>Tension | <b>52</b> |
|                |            |                  |  |     |                       |           |
| 765kV<br>S/C   | Horizontal | ACSR<br>BERSIMIS | Normal route without constraint                                | 400 | "I" String            | <b>74</b> |
|                |            |                  |  |     | "V" String<br>Tension |           |
|                |            |                  | Forest   | 300 | "V" String<br>Tension | <b>65</b> |
|                |            |                  | Urban area / populated area / approach section near substation | 250 | "V" String<br>Tension | <b>62</b> |
|                |            |                  |  |     |                       |           |
| ±800kV<br>HVDC | Horizontal | ACSR<br>Lapwing  | Normal route without constraint/Forest/Urban                   | 400 | "Y" String            | 69        |
|                |            |                  |  |     |                       |           |
| ±500kV<br>HVDC | Horizontal | ACSR<br>Lapwing  | Normal route without constraint/Forest/Urban                   | 400 | "V" String            | 52        |
|                | Vertical   |                  |  | 400 | "I" String            | <b>46</b> |

|              |                         |               |   |     |                       |           |
|--------------|-------------------------|---------------|---|-----|-----------------------|-----------|
| 400kV<br>D/C |                         | ACSR<br>MOOSE | Normal route<br>without<br>constraint                                   | 300 | "V" String<br>Tension | <b>40</b> |
|              |                         |               | Forest  |     | "V" String<br>Tension |           |
|              |                         |               | Urban area /<br>populated area /<br>approach section<br>near substation | 250 | "V" String<br>Tension | <b>38</b> |
|              |                         |               |   |     |                       |           |
| 400kV<br>S/C | Horizontal/<br>Vertical | ACSR<br>MOOSE | Normal route<br>without<br>constraint                                   | 400 | "I" String            | <b>52</b> |
|              |                         |               |   |     | "V" String            |           |
|              |                         |               |   |     | Tension               |           |
|              |                         |               | Forest  | 300 | "V" String<br>Tension | <b>47</b> |
|              |                         |               |   |     |                       |           |
|              |                         |               | Urban area /<br>populated area /<br>approach section<br>near substation | 250 | "V" String<br>Tension | <b>44</b> |
|              |                         |               |   |     |                       |           |
| 1200kV       | Horizontal              | ACSR Moose    | Normal route<br>without<br>constraint/Forest/<br>Urban                  | 400 | "V" String            | <b>89</b> |
|              |                         |               |   |     |                       |           |

|               |          |                 |   |     |                                     |           |
|---------------|----------|-----------------|---|-----|-------------------------------------|-----------|
| 220kV<br>D/C  | Vertical | ACSR<br>ZEBRA   | Normal route<br>without<br>constraint                                   | 350 | "I" String<br>"V" String<br>Tension | <b>32</b> |
|               |          |                 | Forest  | 300 | "V" String<br>Tension               |           |
|               |          |                 | Urban area /<br>populated area /<br>approach section<br>near substation | 200 | "V" String<br>Tension               | <b>24</b> |
|               |          |                 |   |     |                                     |           |
|               |          |                 |   |     |                                     |           |
| 132kV<br>D/C  | Vertical | ACSR<br>PANTHER | Normal route<br>without<br>constraint                                   | 320 | "I" String<br>"V" String<br>Tension | <b>25</b> |
|               |          |                 | Forest  | 200 | "V" String<br>Tension               |           |
|               |          |                 | Urban area /<br>populated area /<br>approach section<br>near substation | 150 | "V" String<br>Tension               | <b>19</b> |
|               |          |                 |   |     |                                     |           |
|               |          |                 |   |     |                                     |           |
| 110 kV<br>D/C |          | ACSR<br>PANTHER | Normal route<br>without<br>constraint                                   | 305 | "I" String<br>"V" String<br>Tension | <b>22</b> |
|               |          |                 |   |     |                                     |           |

|   |          |                 |   |     |            |           |  |  |
|---|----------|-----------------|---|-----|------------|-----------|--|--|
|   |          |                 | Forest  | 200 | "V" String | <b>19</b> |  |  |
|   |          |                 |   |     | Tension    |           |  |  |
|   |          |                 | Urban area /<br>populated area /<br>approach section<br>near substation | 150 | "V" String | <b>17</b> |  |  |
|   |          |                 |   |     | Tension    |           |  |  |
|   |          |                 |   |     |            |           |  |  |
| 66kV  | Vertical | ACSR<br>PANTHER | Normal route<br>without<br>constraint                                   | 250 | "I" String | <b>18</b> |  |  |
|   |          |                 |   |     | "V" String |           |  |  |
|   |          |                 |   |     | Tension    |           |  |  |
|   |          |                 |   |     |            |           |  |  |
|   |          |                 | Forest  | 150 | "V" String | <b>14</b> |  |  |
|   |          |                 |   |     | Tension    |           |  |  |
|   |          |                 |   |     |            |           |  |  |
| Urban area /<br>populated area /<br>approach section<br>near substation | 100      | "V" String      | <b>13</b>   |     |            |           |  |  |
|   |          | Tension         |   |     |            |           |  |  |

Note: D/c : double circuit; S/c: single circuit

## Annexure-C.2

| POWER SYSTEM DEVELOPMENT FUND            |             |   |  |                |                     |                                   |                     |  |                     |                          |  |  |   |
|--|-------------|---|--|----------------|---------------------|-----------------------------------|---------------------|--|---------------------|--------------------------|--|--|---|
| Status of the Projects in Eastern Region |             |   |  |                |                     |                                   |                     |  |                     |                          |  |  |   |
| Sl No                                    | State       | Entity  | Name of the scheme   | Grant Approved | Grant sanctioned on | 1st Installment grant released on | Completion Schedule | Completion schedule w.r.t date of 1st instalment | Grant aviled so far | Under process of release | Total awards amount of placed of till date | Latest status  |   |
| 1  | Bihar       | BSPTCL  | Renovation and Upgradation of protection system of substations. (18)   | 64.22          | 42135               | 42506                             | 24                  | 43236  | 56.04               |                          | 69.195                                     | 90% grant availed on award cost.   |   |
| 2  |             |   | Installation of Capacitor bank in 20 Nos of Grid Sub Station. (74)   | 18.882         | 42618               | 43550                             | 24                  | 44281  | 16.99               |                          | 21.55                                      |  |   |
|  |             |   | <b>Total</b>   | <b>83.10</b>   |                     |                                   |                     |  | <b>73.03</b>        |                          | <b>90.745</b>                              |  |   |
| 5  | Jharkhand   | JUSNL   | Renovation & Upgradation of protection system of Jharkhnad. (161)  | 138.13         | 15-Nov-17           | 28-Mar-19                         | 16                  | 28-Jul-20  | 114.68              | 1.01                     | 145.674                                    | 90% grant availed on award cost. Project closure is expected by Q-2 of 2021-22.  |   |
| 6  |             |   | Reliable Communication & data acquisition system upto 132kV Substations ER. (177)  | 22.36          | 24-May-19           |                                   | 24                  |  |                     |                          |  |  | Price bid has been opened. Tender on awarding stage.  |
|  |             |   | <b>Total</b>   | <b>160.49</b>  |                     |                                   |                     |  | <b>114.68</b>       |                          | <b>145.674</b>                             |  |   |
| 7  | Odisha      | OPTCL   | Renovation and Upgradation of protection system of substations. (08)   | 162.50         | 11-May-15           | 22-Mar-16                         | 24                  | 22-Mar-18  | 46.04               |                          | 63.31                                      | Project Completed on Dec-20. Request for release of final 10 % fund has been placed.   |   |
| 8  |             |   | Implementation of OPGW based reliable communication at 132 kv and above substations. (128)   | 25.61          | 15-Nov-17           | 29-Mar-19                         | 36                  | 29-Mar-22  | 23.04               |                          |  | 51.22  | 90% grant availed on award cost. Work In Progress   |
| 9  |             |   | Installation of 125 MVAR Bus Reactor along with construction of associated by each at 400kV Grid S/S of Mendhasal, Meramundali & New Duburi for VAR control & stabilisation of system voltage. (179)           | 27.23          | 27-Jul-18           | 1-Apr-19                          | 18                  | 1-Oct-20   | 8.17                |                          |  | 24.5   | 90% grant availed . Rest work in progress   |
| 10                                       |             |   | Implementation of Automatic Demand Management System (ADMS) in SLDC, Odisha. (196)   | 2.93           | 24-May-19           | 19-Feb-20                         | 10                  | 19-Dec-20  | 0.29                |                          |  | 0.29   | 10% grant availed   |
| 11                                       |             |   | Protection Upgradation and installation os Substation Automatic System (SAS) for seven nos of 220/132/33kV Substations (Balasore, Bidanasi, Budhipadar, Katapali, Narendrapur, New-Bolangir & Paradeep). (209) | 29.56          | 24-May-19           | 13-Feb-20                         | 18                  | 13-Aug-21  | 8.87                |                          |  | 32.85  | 30% grant availed. Work in Progress.  |
| 12                                       |             | OHPCL   | Renovation and Upgradation of protection and control system of OHPC. (109)   | 22.35          | 22-May-17           | 25-May-18                         | 24                  | 25-May-20  | 14.94               |                          |  | 21.25  | 90% grant availed on award cost.  |
|  |             |   | <b>Total</b>   | <b>270.18</b>  |                     |                                   |                     |  | <b>101.35</b>       |                          | <b>193.42</b>                              |  |   |
| 14                                       | West Bengal | WBSETCL   | Installation of switchable reactor & shunt capacitor for voltage improvement. (88)   | 43.37          | 22-May-17           | 22-Jun-18                         | 19                  | 22-Jan-20  | 33.07               |                          | 40.83                                      | 90% grant availed on award cost. Will get completed by Oct'21  |   |
| 15                                       |             |   | Renovation & Modernisation of Transmission System. (87)  | 70.13          | 22-May-17           | 25-Jun-18                         | 25                  | 25-Jul-20  | 63.12               |                          |  | 96.44  | 90% grant availed on award cost. Will get completed by Mar'22   |
| 16                                       |             |   | Installation of Bus Reactors at different 400kV Substation within the state of West Bengal for reactive power management of the Grid. (210)  | 71.74          | 24-May-19           | 23-Oct-19                         | 19                  | 23-May-21  | 39.3                |                          |  | 45.62  | 30% grant availed on award cost. 04 Nos. of Reactors will be commissioned by December 2021. LoA of the 5th Reactor is yet to be placed.                     |
| 17                                       |             |   | Project for establishment of reliable communication and data acquisition at different substation at WBSWTCL. (222)   | 31.19          | 24-May-19           | 23-Oct-19                         | 25                  | 23-Nov-21  | 3.12                |                          |  |  | The tender has been been cancelled for OPGW. Re-tendering has to be done.   |
| 18                                       |             |   | Implementation of Integated system for Scheduling, Accounting, Metering and Settlement of Transactions (SAMAST) system in West Bengal. (197)   | 10.08          | 43910               |                                   | 12                  |  |                     |                          |  |  | 10% grant not yet requested   |
| 19                                       |             | WBPDCL  | Renovation and Modernization of 220/ 132 kV STPS switch yard and implementation of Substaion Automation System. (72)   | 23.48          | 5-Sep-16            | 18-May-17                         | 18                  | 18-Nov-18  | 21.13               |                          |  | 32.09  | Target date for completion of project is Sept.'21 subject to availability of S/D & Covid scenario. Request for release for final 10% grant has been placed. |
| 21                                       | WBPDCL      | Renovation and Modernization of switchyard and related protection system of different power stations (BTPS, BKTPS and KTPS) of WBPDCL (155) | 45.16  | 27-Jul-18      | 27-Mar-19           | 12                                | 27-Mar-20           | 34.52  |                     |                          | 41.68                                      | Target date for completion of project is Oct'21, subject to availability of S/D & Covid scenario. 90% grant availed on award cost. |   |
|  |             |   | <b>Total</b>   | <b>295.15</b>  |                     |                                   |                     |  | <b>194.26</b>       |                          | <b>256.661</b>                             |  |   |

| POWER SYSTEM DEVELOPMENT FUND            |        |              |  |                 |                     |                                   |                     |  |                     |                          |  |                                  |
|--|--------|--------------|--|-----------------|---------------------|-----------------------------------|---------------------|--|---------------------|--------------------------|--|----------------------------------|
| Status of the Projects in Eastern Region |        |              |  |                 |                     |                                   |                     |  |                     |                          |  |                                  |
| Sl No                                    | State  | Entity       | Name of the scheme   | Grant Approved  | Grant sanctioned on | 1st Installment grant released on | Completion Schedule | Completion schedule w.r.t date of 1st instalment | Grant aviled so far | Under process of release | Total awards amount of placed of till date | Latest status                    |
| 22                                       | DVC    | DVC          | Renovation and Upgradatg of the protection and control system of Ramgarh Sub Station. (81)   | 25.96           | 2-Jan-17            | 31-May-17                         | 24                  | 31-May-19  | 22.95               | 2.57                     | 28.603                                     | 90% grant availed on award cost. |
| 23                                       |        |              | Renovation and Modernization of control and protection system and replacement of equipment at Parulia, Durgapur, Kalyanewari, Giridhi Jamsedpur, Barjora, Burnpur, Dhanbad and Bundwan substation. (106) | 140.50          | 16-May-17           | 14-Dec-17                         | 24                  | 14-Dec-19  | 102.43              | 0.98                     | 127.684                                    |                                  |
| <b>Total</b>                             |        |              |  | <b>166.46</b>   |                     |                                   |                     |  | <b>125.38</b>       |                          | <b>156.287</b>                             |                                  |
| 24                                       | Sikkim | ENPD, Sikkim | Drawing of optical ground wire (OPGW) cables on existing 132kV & 66kV transmission lines and integration of leftover substations with State Load Despatch Centre, Sikkim. (173)                          | 10.00           | 24-May-19           |                                   | 18                  |  | 3.00                |                          | 20   | 30% grant availed on award cost  |
| <b>Total</b>                             |        |              |  | <b>10.00</b>    |                     |                                   |                     |  | <b>3.00</b>         |                          | <b>20.00</b>                               |                                  |
| 26                                       | ERPC   | ERPC         | Creation and Maintenance of web based protection database management. (67)   | 20.00           | 17-Mar-16           | 28-Jun-16                         | 18                  | 28-Dec-17  | 14.83               |                          | 16.48                                      | Project Completed                |
| 27                                       |        |              | Study Programme on power trading at NORD POOL Academy for Power System Engineers of Eastern Region. (122)  | 5.46            | 27-Jul-18           | 27-Mar-19                         | 13                  | 27-Apr-20  | 4.61                |                          | 5.37                                       |                                  |
| 28                                       |        |              | Traning Program for Power system Engineers of various constituents of Eastern Region. (117)  | 0.61            | 27-Jul-18           | 11-Apr-19                         | 24                  | 11-Apr-21  | 0.54                |                          | 0.60888                                    | 90% grant availed on award cost. |
| <b>Total</b>                             |        |              |  | <b>26.07</b>    |                     |                                   |                     |  | <b>19.98</b>        |                          | <b>22.45888</b>                            |                                  |
| <b>GrandTotal</b>                        |        |              |  | <b>1,011.46</b> |                     |                                   |                     |  | <b>631.68</b>       |                          | <b>885.25</b>                              |                                  |

## Date of PFR testing scheduled /completed for generating stations in ER

| Sr. No | Station            | Generating Unit | Test schedule  | Remarks                                   |
|--------|--------------------|-----------------|--|---|
| 1      | TALCHER<br>STAGE 2 | 3               | Unit 3 - 5: 23-11-2020 to<br>28-11-2020                    | Testing for unit 6 yet to<br>be conducted |
| 2      |                    | 4               |  |   |
| 3      |                    | 5               |  |   |
| 4      |                    | 6               |  |   |
| 5      | Farakka            | 2               | 01-02-2021 to 10-01-<br>2021                               | Testing completed                         |
| 6      |                    | 3               |  |   |
| 7      |                    | 4               |  |   |
| 8      |                    | 5               |  |   |
| 9      |                    | 6               |  |   |
| 10     | Kahalgaon          | 1               | August'21  | Testing completed for<br>Unit 1           |
| 11     |                    | 5               |  |   |
| 12     |                    | 6               |  |   |
| 13     |                    | 7               |  |   |
| 14     | Barh               | 4               | 18-02-2021 to 21-02-<br>2021                               | Scheduled                                 |
| 15     |                    | 5               |  |   |
| 16     | Teesta V           | 1               | 07-01-2021 - 08-01-2021                                    | Testing completed                         |
| 17     | Teesta III         | 1               | 30-01-2021 - 10-02-2021                                    | Testing completed                         |
| 18     |                    | 2               |  |   |
| 19     |                    | 3               |  |   |
| 20     |                    | 4               |  |   |
| 21     |                    | 5               |  |   |
| 22     |                    | 6               |  |   |
| 23     | Dikchu             | 1               | Unit#1: 6th & 7th April' 21<br>Unit#2: 8th & 9th April' 21 | Scheduled                                 |
| 24     |                    | 2               |  |   |
| 25     | MPL                | 1               | -  | Postponed due to<br>some technical issue  |
| 26     |                    | 2               |  |   |
| 27     | GMR                | 1               | August'21  | Testing Completed                         |
| 28     |                    | 2               |  |   |
| 29     |                    | 3               |  |   |
| 30     | JITPL              | 1               | August'21  | Scheduled                                 |
| 31     |                    | 2               |  |   |
| 32     |                    | 3               |  |   |
| 33     | NPGCL              | 1               | August'21  | Testing Completed                         |
| 34     | BRBCL              |                 | 1 <sup>st</sup> Week of August'21                          | Testing Completed                         |
| 35     | APNRL              | 1&2             | July'21-August-21  | Testing Completed                         |



## Annexure C.6

| Power Plant              | Unit No  | PSS tuned (Yes/No) | PSS in Service (Yes/No) | Last PSS Tuning Date | Whether Done in Last 3 Years | Whether Next to be planned | Planned Next PSS Tuning   |
|--------------------------|----------|--------------------|-------------------------|----------------------|------------------------------|----------------------------|---|
| <b>West Bengal</b>       |          |                    |                         |                      |                              |                            |   |
| Kolaghat-WBPDCL          | 1        | No                 | Yes                     | Long Back            | No                           | Yes                        | Under retirement  |
| Kolaghat-WBPDCL          | 2        | No                 | Yes                     | Long Back            | No                           | Yes                        | Under retirement  |
| <b>Kolaghat-WBPDCL</b>   | <b>3</b> | No                 | Yes                     | Long Back            | No                           | Yes                        | To be done within Jan./Feb. 2022 after DAVR replacement.                      |
| <b>Bakreshwar-WBPDCL</b> | <b>2</b> | Yes                | Yes                     | 2019                 | Yes                          | Yes                        | PSS tuning to be done during Unit O/H in the month of November-December, 2021 |
| <b>Bakreshwar-WBPDCL</b> | <b>4</b> | Yes                | Yes                     | 2019                 | Yes                          | Yes                        | BHEL offer received. PSS tuning to be done within Dec , 2021                  |
| <b>Bakreshwar-WBPDCL</b> | <b>5</b> | Yes                | Yes                     | 2019                 | Yes                          | Yes                        | BHEL offer received. PSS tuning to be done within Dec , 2021                  |
| DPL                      | 8        | No                 | Yes                     | No                   | No Detail                    | Yes                        | To be updated by WBPDCL/DPL   |
| PPSP                     | 1        | No                 | Yes                     | 2009                 | No                           | Yes                        | Dec-21  |
| PPSP                     | 2        | No                 | Yes                     | 2009                 | No                           | Yes                        | Dec-21  |
| PPSP                     | 3        | No                 | Yes                     | 2009                 | No                           | Yes                        | Dec-21  |
| PPSP                     | 4        | No                 | Yes                     | 2009                 | No                           | Yes                        | Dec-21  |
| TLDP III                 | 4 x 33   |                    |                         | No Detail            | No Detail                    | Yes                        | To be updated by WBSEDCL  |
| TLDP IV                  | 4 X 44   |                    |                         | No Detail            | No Detail                    | Yes                        | To be updated by WBSEDCL  |
| <b>DVC</b>               |          |                    |                         |                      |                              |                            |   |
| Bokaro B 210 MW          | 3        |                    |                         |                      | No Detail                    | Yes                        | Unit Is out of Service  |
| Raghunathpur-DVC         | 1        | No                 | No                      |                      | No Detail                    | Yes                        | Will be done after AOH  |
| Raghunathpur-DVC         | 2        | No                 | No                      |                      | No Detail                    | Yes                        | Jun-21  |
| Waria                    | 4        | Yes                | Yes                     | 2008                 | No                           | Yes                        | Unit Is out of Service  |
| <b>ISGS</b>              |          |                    |                         |                      |                              |                            |   |
| Kahalgaon NTPC           | 1        | Yes                | Yes                     | 2017                 | Yes                          | Yes                        | Apr-21  |
| Kahalgaon NTPC           | 3        | Yes                | Yes                     | 2016                 | Yes                          | Yes                        | Jul-21  |
| Kahalgaon NTPC           | 4        | Yes                | Yes                     | 2015                 | No                           | Yes                        | Mar-21  |
| Kahalgaon NTPC           | 6        | Yes                | Yes                     | 2009                 | No                           | Yes                        | Mar-21  |
| Talcher Stage 2          | 3        | Yes                | Yes                     | 2016                 | Yes                          | Yes                        | Nov-21  |
| Talcher Stage 2          | 4        | Yes                | Yes                     | No Details           | No Details                   | Yes                        | Nov-21  |

|                 |           |     |     |                           |            |     |                       |
|-----------------|-----------|-----|-----|---------------------------|------------|-----|-----------------------|
| Talcher Stage 2 | 5         | Yes | Yes | No Details                | No Details | Yes | Nov-21                |
| Talcher Stage 2 | 6         | Yes | Yes | 2016                      | Yes        | Yes | Nov-21                |
| Barh NTPC       | 4         |     |     | 2015                      |            | Yes | In Next AOH           |
| Barh NTPC       | 5         |     |     | During Unit commissioning |            | Yes | June 2021 (AOH)       |
| Teesta V        | 1         | Yes | Yes | 2008                      | No         | Yes | Oct-21                |
| Teesta V        | 2         | Yes | Yes | 2008                      | No         | Yes | Oct-21                |
| Teesta V        | 3         | Yes | Yes | 2008                      | No         | Yes | Oct-21                |
| BRBCL           | 1         | No  | Yes | Vendor to Do              | No         | Yes | Jun-21                |
| BRBCL           | 2         | Yes | Yes | 2019                      | Yes        | Yes | Jun-21                |
| BRBCL           | 3         | No  | Yes | Vendor to Do              | No         | Yes | Jun-21                |
| KBUNL           | 1         | Yes | Yes | 2014                      | No         | Yes | 2021-22               |
| KBUNL           | 2         | Yes | Yes | 2014                      | No         | Yes | 2021-22               |
| KBUNL           | 3         | Yes | Yes | Not Available             | No         | Yes | 2021-22               |
| KBUNL           | 4         | Yes | Yes | Not Available             | No         | Yes | 2021-22               |
| Rangit          | 3 x 20    |     |     | Not Available             | No         | Yes | To be updated by NHPC |
| <b>IPP</b>      |           |     |     |                           |            |     |                       |
| Jorethang       | 1         | Yes | Yes | 2015                      | No         | Yes | Apr-21                |
| Jorethang       | 2         | Yes | Yes | 2015                      | No         | Yes | Apr-21                |
| ADHUNIK         | 1         | Yes | YES | 2013                      | No         | Yes | Mar-21                |
| ADHUNIK         | 2         | Yes | YES | 2013                      | No         | Yes | Mar-21                |
| JITPL           | 1         | Yes | Yes | 2016                      | Yes        | Yes | Jul-21                |
| JITPL           | 2         | Yes | Yes | 2016                      | Yes        | Yes | Jul-21                |
| GMR             | 1         | Yes | Yes | 2013                      | No         | Yes | Dec-21                |
| GMR             | 2         | Yes | Yes | 2013                      | No         | Yes | Dec-21                |
| GMR             | 3         | Yes | Yes | 2013                      | No         | Yes | Dec-21                |
| <b>Orissa</b>   |           |     |     |                           |            |     |                       |
| IB TPS          | 1         | Yes | Yes | 2011                      | No         | Yes | Mar'2021              |
| IB TPS          | 2         | Yes | Yes | 2012                      | No         | Yes | Mar'2021              |
| Upper Indravati | 1         | Yes | No  | 2015                      | No         | Yes | To be updated by OHPC |
| Upper Indravati | 2         | Yes | No  | 2015                      | No         | Yes | To be updated by OHPC |
| Upper Indravati | 3         | Yes | No  | 2000                      | No         | Yes | To be updated by OHPC |
| Upper Indravati | 4         | Yes | No  | 2001                      | No         | Yes | To be updated by OHPC |
| Balimela        | 1 (60 MW) |     |     | No detail                 |            | Yes | To be updated by OHPC |

|                  |           |     |     |           |     |     |                         |
|------------------|-----------|-----|-----|-----------|-----|-----|-------------------------|
| Balimela         | 2 (60 MW) |     |     | No detail |     | Yes | To be updated by OHPC   |
| Balimela         | 3 (60 MW) | No  | No  | Not tuned | No  | Yes | To be updated by OHPC   |
| Balimela         | 4 (60 MW) | No  | No  | Not tuned | No  | Yes | To be updated by OHPC   |
| Balimela         | 5 (60 MW) | No  | No  | Not tuned | No  | Yes | To be updated by OHPC   |
| Balimela         | 6 (60 MW) | No  | No  | Not tuned | No  | Yes | To be updated by OHPC   |
| Balimela         | 7 (75 MW) | No  | No  | Not tuned | No  | Yes | To be updated by OHPC   |
| Balimela         | 8 (75 MW) | No  | No  | Not tuned | No  | Yes | To be updated by OHPC   |
| Upper Kolab      | 1         | Yes | Yes | 2007      | No  | Yes | To be updated by OHPC   |
| Upper Kolab      | 2         | Yes | Yes | 2007      | No  | Yes | To be updated by OHPC   |
| Upper Kolab      | 3         | Yes | Yes | 2007      | No  | Yes | To be updated by OHPC   |
| Upper Kolab      | 4         | Yes | Yes | 2007      | No  | Yes | To be updated by OHPC   |
| Rengali          | 1         | Yes | Yes | Not tuned | No  | Yes | To be updated by OHPC   |
| Rengali          | 2         | Yes | Yes | Not tuned | No  | Yes | To be updated by OHPC   |
| Rengali          | 3         | Yes | Yes | Not tuned | No  | Yes | To be updated by OHPC   |
| Rengali          | 4         | Yes | Yes | Not tuned | No  | Yes | To be updated by OHPC   |
| Rengali          | 5         | No  | Yes | Not tuned | No  | Yes | To be updated by OHPC   |
| Sterlite         | 4 X 600   |     |     | No detail |     | Yes | To be updated by SLDC   |
| <b>Jharkhand</b> |           |     |     |           |     |     |                         |
| Tenughat         | 1         | Yes | Yes | 2017      | Yes | Yes | Dec-21                  |
| Tenughat         | 2         | Yes | Yes | 2017      | Yes | Yes | Dec-21                  |
| Subarnrekha      | 2 X 65    |     |     |           |     | Yes | To be updated           |
| <b>Bihar</b>     |           |     |     |           |     |     |                         |
| BTPS             | 6 (110)   |     |     |           |     | Yes | To be updated by BSPGCL |
| BTPS             | 7 (110)   |     |     |           |     | Yes | To be updated by BSPGCL |
| BTPS             | 8         |     |     |           |     | Yes | To be updated by BSPGCL |
| BTPS             | 9         |     |     |           |     | Yes | To be updated by BSPGCL |
| <b>Bhutan</b>    |           |     |     |           |     |     |                         |
| Tala             | 1         | No  | Yes |           |     | Yes | To be updated by BPC    |
| Tala             | 2         | No  | Yes |           |     | Yes | To be updated by BPC    |
| Tala             | 3         | No  | Yes |           |     | Yes | To be updated by BPC    |
| Tala             | 4         | No  | Yes |           |     | Yes | To be updated by BPC    |
| Tala             | 5         | No  | Yes |           |     | Yes | To be updated by BPC    |
| Tala             | 6         | No  | Yes |           |     | Yes | To be updated by BPC    |
| Chukha           | 1         | No  | Yes | 2005      | No  | Yes | To be updated by BPC    |

|           |   |    |     |      |    |     |                      |
|-----------|---|----|-----|------|----|-----|----------------------|
| Chukha    | 2 | No | Yes | 2005 | No | Yes | To be updated by BPC |
| Chukha    | 3 | No | Yes | 2005 | No | Yes | To be updated by BPC |
| Chukha    | 4 | No | Yes | 2005 | No | Yes | To be updated by BPC |
| Mangdechu | 1 | No | Yes |      |    | Yes | Sep-21               |
| Mangdechu | 2 | No | Yes |      |    | Yes | Sep-21               |

## Annexure C.12

| Statewise transmission adequacy |                   |  |  |                                       |   |                   |                            |                  |                                |                              |  |  |
|---------------------------------|-------------------|--|--|---------------------------------------|---|-------------------|----------------------------|------------------|--------------------------------|------------------------------|--|--|
| Sl.NO.                          | Name of the state | Antecedent condition   | Likely constraints   | Future element to relieve constraints |   | Executing agency  | Details of SCM/plan /forum | Date of approval | Expected date of commissioning | if delayed from SCOD, Reason | Revised expected date of commissioning | Other reason   |
| 1                               | Bihar             | High drawal at Sipara (to meet the demand of City of Patna) by Bihar | N-1 non-compliant of 220kV Patna-Sipara T/c line                                     | Intra State                           | Creation of 400/220 kV Jakkanpur Substation by LILO of NPGC-Patna D/C Line at Jakkanpur                                 | BSPTCL/B GCL      | 18th SCEM                  | 13-Jun-16        | Mar-22                         |                              |  |  |
|                                 |                   |  |  | Intra State                           | 220 kV Down stream of Jakkanpur   | BSPTCL/B GCL      | 2nd ERPCTP                 | 30-Sep-20        | NA                             |                              |  | To be taken after commissioning of Jakkanpur Substation  |
|                                 |                   |  |  | Intra State                           | LILO of 400 kV Patna-Balia DC at Naubatpur  |                   | 2nd ERPCTP                 | 30-Sep-20        | NA                             |                              |  |  |
|                                 |                   |  |  | Intra State                           | 220 kV Down stream of Naubatpur   |                   | 2nd ERPCTP                 | 30-Sep-20        | NA                             |                              |  |  |
|                                 |                   |  |  | Intra State                           | Reconductoring of Patna-Sipara with HTLS Conductor  |                   | 2nd ERPCTP                 | 30-Sep-20        | NA                             |                              |  |  |
| 2                               | Bihar             | During Peak demands of Bihar and Nepal                               | N-1 non-compliant of 2x200 MVA 400/132kV ICTs at Motihari                            | ISTS                                  | 1x 315 MVA ICT at Motihari  | PMTL              | 18th SCEM                  | 13-Jun-16        | Apr-22                         |                              |  | Third 315 MVA ICT was being charged through 132 kV GIS Bus at Motihari on 21-04-2021. Just after charging of new ICT, 132kV Main bus-1 at Motihari tripped due to problem at Bus extension module. After this ICT could not be charged yet |
| 3                               | Jharkhand         | During Peak demand of Jharkhand                                      | N-1 non-compliant of 2x315 MVA 400/220 kV ICTs at Ranchi                             | ISTS                                  | 3rd 500 MVA ICT at Ranchi   | Not yet allocated | 3rd ERPCTP                 | 09-Feb-21        | Not available                  |                              |  |  |
| 4                               | Jharkhand         | During Peak demand of Jharkhand                                      | N-1 non-compliant of 220 kV Maithon(PG)-Dumka D/C                                    | Intra State                           | LILO of 220kV Tenughat - Govindpur D/c line at Jainamore and Dhanbad  | JUSNL             | 1st Consultation Meeting   | 27-Dec-21        | Dec-23                         |                              |  | Dec 2023(for 02 bays at Dhanbad) Under administrative approval of State Government Level   |
| 5                               | DVC               | 1. Less generation at CTPS<br>2. Less generation at Koderma          | N-1 non-compliant of 220 kV Maithon(PG)-Kalyaneswari D/C and Maithon(PG)-Dhanbad D/C | Intra State                           | 1. Construction of 400/220 kV Substation at RaghunatpurTPS  | DVC               | 4th ERPCTP                 | 09-Sep-21        | Mar-23                         |                              |  |  |
|                                 |                   |  |  |                                       | 2. LILO of 220 kV Kalyaneswari-CTPS D/C at RaghunatpurTPS   |                   |                            | 09-Sep-21        | Mar-23                         |                              |  |  |
|                                 |                   |  |  |                                       | 3. Construction of 400/220 kV Substation at Mejia-B TPS   |                   |                            | 09-Sep-21        | Mar-23                         |                              |  |  |
|                                 |                   |  |  |                                       | 4. LILO of 220 kV Mejia-A TPS-Barjora D/C at Mejia-B TPS  |                   |                            | 09-Sep-21        | Mar-23                         |                              |  |  |
| 6                               | DVC               | Decommissioning of generators at Bokaro B                            | N-1 non-compliant of 2x315 MVA 400/220 kV ICTs at Bokaro                             | Intra State                           | 1. Construction of 400/220 kV Substation at RaghunatpurTPS<br>2. LILO of 220 kV Kalyaneswari-CTPS D/C at RaghunatpurTPS | DVC               | 4th ERPCTP                 | 09-Sep-21        | Mar-23                         |                              |  |  |
| 7                               | DVC and WB        | High Demand of WB and less generation at DPL                         | N-1 non-compliant of 220 kV Waria(DVC)-Bidhannagar(WB) D/C                           | Intra State                           | 3rd 315 MVA ICT at Bidhannagar (WB)   | WBSETCL           | 8th SSCM/4th ERPCTP        | NA               | Jun-22                         |                              |  |  |

|    |                                      |  |  |             |  |         |                  |           |               |     |                                   |  |  |
|----|--------------------------------------|--|--|-------------|--|---------|------------------|-----------|---------------|-----|-----------------------------------|--|--|
| 8  | WB                                   | High Demand of West Bengal   | N-1 non-compliant of 220 kV Rajarhat-Newtown AA3 D/C, 220 kV Jeerat Barasat D/C and 220 kV Subhasgram-EMSS D/C | Intra State | 1. Commissioning of Rajarhat (POWERGRID) –New Town AA2 220 kV D/c, | WBSETCL | 18th SCEM        | 13-Jun-16 | Dec-21 (ROW)  | ROW | Rajarhat-Barasat 220kV DC May-22, | Due to ROW New town AA2 could not complied   |  |
|    |                                      |  |  |             | 2. Rajarhat (PGCIL) –Barasat/Jeerat 220 kV D/c                     |         |                  | 13-Jun-16 | Dec-21 (ROW)  | ROW |                                   |  |  |
|    |                                      |  |  |             | 3. Subashgram (PGCIL) –Baraipur 220 kV D/c.                        |         |                  | 13-Jun-16 | Dec-21 (ROW)  | ROW |                                   |  |  |
|    |                                      |  |  |             | 4. Reconductoring of 220 kV Rajarhat-Newtown AA3 D/C               |         |                  | 13-Jun-16 | Dec-21 (ROW)  | ROW |                                   |  |  |
| 9  | WB                                   | High Demand of West Bengal   | N-1 non-compliant of 220 kV Subhasgram (WB)-Lakshmikantpur D/C   | Intra State | Commissioning of 220 kV Subhasgram Baraipur D/C                    | WBSETCL | 18th SCEM        | 13-Jun-16 | Dec-21 (ROW)  | ROW | Apr-22                            | Baraipur substation is under-construction which is supposed to be completed by Dec, 2021 (SPS is available to take care of contingency for the time being) |  |
| 10 | WB                                   | High Demand of West Bengal   | N-1 non-compliant of 220 kV Subhasgram (PG) –Subhasgram (WB) D/C   | Intra State | Commissioning of 220 kV Subhasgram Baraipur D/C                    | WBSETCL | 18th SCEM        | 13-Jun-16 | Dec-21 (ROW)  | ROW | Apr-22                            | Baraipur substation is under-construction which is supposed to be completed by Dec, 2021 (SPS is available to take care of contingency for the time being) |  |
| 11 | Odisha                               | High Drawl by Odisha at Rourkela                                     | N-1 non-compliant of 220 kV Rourkela(PG)-Tarkera D/C   | Intra State | Construction of second 220 kV Rourkela(PG)-Tarkera D/C             | OPTCL   | 1st Consultation | 27-Dec-21 | Not available |     |                                   |  |  |
| 12 | Improvement of Reliability of System | Good generation of MPL and high import from WR and High Export to NR | N-1 non-compliant of 400 kV MPL-Maithon D/C  | Inter State | Reconductoring of MPL-Maithon D/C with HTLS conductor              | PGCIL   | 17th SCEM        | 25-May-15 | Feb-22        |     |                                   |  |  |

## Anticipated Peak Demand (in MW) of ER &amp; its constituents

Feb-22

| 1          | BIHAR  | Demand (MW) | Energy Requirement (MU) |
|------------|--|-------------|-------------------------|
|            | NET MAX DEMAND   | 5150        | 2475                    |
|            | NET POWER AVAILABILITY- Own Sources  | 696         | 207                     |
|            | Central Sector+Bi-Lateral  | 6226        | 2659                    |
|            | SURPLUS(+)/DEFICIT(-)  | 1772        | 391                     |
| <b>2</b>   | <b>JHARKHAND</b>   |             |                         |
|            | NET MAXIMUM DEMAND   | 1850        | 825                     |
|            | NET POWER AVAILABILITY- Own Source   | 359         | 173                     |
|            | Central Sector+Bi-Lateral+IPP  | 1076        | 460                     |
|            | SURPLUS(+)/DEFICIT(-)  | -415        | -192                    |
| <b>3</b>   | <b>DVC</b>   |             |                         |
|            | NET MAXIMUM DEMAND   | 3140        | 1828                    |
|            | NET POWER AVAILABILITY- Own Source   | 5385        | 2872                    |
|            | Central Sector+MPL   | 286         | 136                     |
|            | Bi-lateral export by DVC   | 2515        | 1690                    |
|            | SURPLUS(+)/DEFICIT(-) AFTER EXPORT   | 16          | -510                    |
| <b>4</b>   | <b>ODISHA</b>  |             |                         |
|            | NET MAXIMUM DEMAND (OWN)   | 3950        | 2218                    |
|            | NET MAXIMUM DEMAND (In Case of CPP Drawal)   | 5200        | 2860                    |
|            | NET POWER AVAILABILITY- Own Source   | 3552        | 2081                    |
|            | Central Sector   | 1912        | 770                     |
|            | SURPLUS(+)/DEFICIT(-) (OWN)  | 1514        | 633                     |
|            | SURPLUS(+)/DEFICIT(-) (In Case, 600 MW CPP Drawal)                                     | 264         | -9                      |
| <b>5</b>   | <b>WEST BENGAL</b>   |             |                         |
| <b>5.1</b> | <b>WBSEDCL</b>   |             |                         |
|            | NET MAXIMUM DEMAND   | 5230        | 3030                    |
|            | NET MAXIMUM DEMAND (Incl. Sikkim)  | 5365        | 3117                    |
|            | NET POWER AVAILABILITY- Own Source (Incl. DPL)   | 4956        | 2046                    |
|            | Central Sector+Bi-lateral+IPP&CPP+TLDP   | 2264        | 835                     |
|            | EXPORT (To SIKKIM)   | 5           | 4                       |
|            | SURPLUS(+)/DEFICIT(-) AFTER EXPORT   | 1855        | -236                    |
| <b>5.2</b> | <b>IPCL</b>  |             |                         |
|            | IPCL Demand  | 130         | 84                      |
|            | IPCL Import  | 130         | 84                      |
|            | SURPLUS(+)/DEFICIT(-)  | 0           | 0                       |
| <b>5.3</b> | <b>CESC</b>  |             |                         |
|            | NET MAXIMUM DEMAND   | 1550        | 640                     |
|            | NET POWER AVAILABILITY- Own Source   | 770         | 426                     |
|            | FROM OTHER SOURCE (IEX)  | 510         | 53                      |
|            | IMPORT FROM HEL  | 270         | 161                     |
|            | TOTAL AVAILABILITY OF CESC   | 1550        | 640                     |
|            | SURPLUS(+)/DEFICIT(-)  | 0           | 0                       |
|            | <b>WEST BENGAL (WBSEDCL+CESC+IPCL)</b>   |             |                         |
|            | (excluding DVC's supply to WBSEDCL's command area)                                     |             |                         |
|            | NET MAXIMUM DEMAND   | 6910        | 3754                    |
|            | NET POWER AVAILABILITY- Own Source   | 5726        | 2472                    |
|            | CS SHARE+BILATERAL+IPP/CPP+TLDP+HEL  | 3044        | 1049                    |
|            | SURPLUS(+)/DEFICIT(-) BEFORE WBSEDCL'S EXPORT  | 1860        | -233                    |
|            | SURPLUS(+)/DEFICIT(-) AFTER WBSEDCL'S EXPORT   | 1855        | -237                    |
| <b>6</b>   | <b>SIKKIM</b>  |             |                         |
|            | NET MAXIMUM DEMAND   | 124         | 65                      |
|            | NET POWER AVAILABILITY- Own Source   | 2           | 1                       |
|            | Central Sector   | 198         | 63                      |
|            | SURPLUS(+)/DEFICIT(-)  | 76          | -1                      |
|            | <b>EASTERN REGION</b>  |             |                         |
|            | NET MAXIMUM DEMAND   | 20710       | 11165                   |
|            | NET MAXIMUM DEMAND (In Case of CPP Drawal of Odisha)                                   | 21808       | 11807                   |
|            | BILATERAL EXPORT BY DVC  | 2515        | 1690                    |
|            | EXPORT BY WBSEDCL TO SIKKIM  | 5           | 3                       |
|            | EXPORT TO B'DESH & NEPAL OTHER THAN DVC  | 642         | 265                     |
|            | NET TOTAL POWER AVAILABILITY OF ER<br>(INCLUDING CS ALLOCATION +BILATERAL+IPP/CPP+HEL) | 28462       | 12943                   |
|            | SURPLUS(+)/DEFICIT(-)  | 4590        | -180                    |
|            | SURPLUS(+)/DEFICIT(-) (In Case, 600 MW CPP Drawal of Odisha)                           | 3492        | -822                    |