

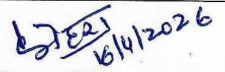

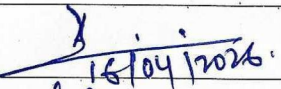

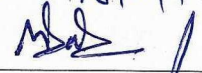

## 157th PCC Meeting

Venue: ERPC Conference Hall, Kolkata

Time: 11:00 Hrs.

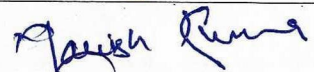
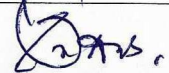
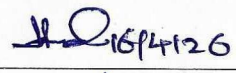
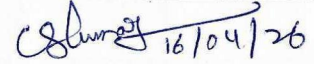
Date: 16.04.2026 (Thursday)

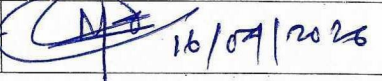





Sl. No.	Name	Designation	Organisation	Contact No.	E-mail Id	Signature
1	Shri K.B. Jagtap	Member Secretary	ERPC	8652776033	mserpc-power@nic.in kb.jagtap@gov.in	 16/04/2026
2	I. K. MEHRA	Dir/SE	ERPC	9810688789	ikmehra@nic.in	 16/04/2026
3	K					
4	Debabrata Biswas	GM	ERLDC	9434740041	dbiswas@grid-india.in	 16/04/2026
5	MANAS DAS	DGM	ERLDC, GRID-INDIA	9007070925	manasdas@grid-india.in	 16/04/2026
6	BIMAL SWARGIA	DGM	- DO -	9435499779	bimal.swargia@grid-india.in	 16/04/2026
7	Gitesh Patel	DM	ERLDC	9147016222	giteshpatel@grid-india.in	 16/04/2026
8	DEEPAK THAKUR	E.Ex.E	BSPTCL	7050115114	deepak.aashish@gmail.com	 16/04/2026
9	MANISH KUMAR	A.Ex.E	BSPTCL	7763817889	manishgce44@gmail.com	 16/04/2026
10	SANJIB KR DAS	DE	WBSETCL	9903236334	sanjib.ee@gmail.com	 16/04/2026
11	NIRMAL MONDAL	ACE	WBSETCL	9433408877	cecb@wbsetcl@gmail.com	 16/04/2026
12	Chandra Shekhar Ku.	Sr. M	JUSNL	7541959265	cs@jusnl@gmail.com	 16/04/2026
13	Alok Raj	LE	MPL	8271658686	alok.raaj@tatapowers.com	 16/04/2026
14	Rajendra Prasad	EBR	TVNL	9031049936	rajendra.prasad@tvnl.in	 16/04/2026
15	MANAS MONDAL	AGM (Engg)	WBPDCL	8918729283	m.mondal@wbpdcl.co.in m.mondal@wbpdcl.co.in	 16/04/2026

157th PCC Meeting

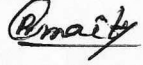
Venue: ERPC Conference Hall, Kolkata

Time: 11:00 Hrs.

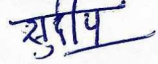
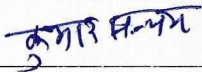
Date: 16.04.2025 (Thursday)

Sl. No.	Name	Designation	Organisation	Contact No.	E-mail Id	Signature
16	Rajit Kr. Koley	<del>WBPDCL</del> Sr. Mgr (CS)	WBPDCL	9474860642	rkr.koley@wbpdcl.co.in	
17	Ranjeet Maity	Sr. Engg.	PRDC	9851800864	ranjeet.maity@prdc.inbtech.com	
18	Nishant Kumar	DGM (OTM)	DMTCL (SEPL)	7987210324	nishant.kumar@energy-sel.com	
19	Avinash Shukla	DM	BRBCL	9453017986	AVINASHSHUKLA@BRBCL.CO.IN	
20	Anik Sen	Mgr.	PGCIL	9310798035	anik.sen@pgcil.co.in	
21	Sudheep Kumar	DGM	POWERGRID, ER1	9431820338	Sudheep.kumar@powergrid.in	
22	Kumar Satyam	AEE	ERPC	7355225072	satyam.24865@gov.in	
23	P P Jena	EE	ERPC	9776198991	ppjena.erpcc@gov.in	
24						
25						
26						
27						
28						
29						
30						

Name	First Join	Email				
ERPC Kolkata	4/16/26, 10:42:49 AM	ERPC@KolkataMST.onmicrosoft.com				
SK SAHOO OHPC RENGALI (Unverified)	4/16/26, 10:43:06 AM					
AWADHESH KUMAR (External)	4/16/26, 10:43:06 AM	AWADHESHKURNWAL@NTPC.CO.IN				
SSARKAR (Unverified)	4/16/26, 10:43:09 AM					
SLDC ODISHA (Unverified)	4/16/26, 10:43:09 AM					
Surya Pratap Rath, AGM OPTCL (Unverified)	4/16/26, 10:56:13 AM					
MRDL OPTCL (Unverified)	4/16/26, 10:59:57 AM					
DEBASHIS BHATTACHARYA (External)	4/16/26, 11:00:27 AM	DEBASHISBHATTACHARYA@NTPC.CO.IN				
Arindam bsptcl (Unverified)	4/16/26, 11:05:47 AM					
dgm,emr,burla (Unverified)	4/16/26, 11:05:47 AM					
Ashish Kumar (External)	4/16/26, 11:05:47 AM	ashish.k@budhilhydro.com				
Bimal Swargiary (External)	4/16/26, 11:05:47 AM	Bimal.swargiary@erldc.onmicrosoft.com				
Mithun Gayen {मिथुन गायेन} (External)	4/16/26, 11:05:47 AM	mithun.gayen@powergrid.in				
Amiya Kumar Pradhan (External)	4/16/26, 11:05:48 AM	Amiya.Pradhan@vedanta.co.in				
PARAG CHATTERJEE (External)	4/16/26, 11:05:48 AM	PARAGCHATTERJEE@NTPC.CO.IN				
Rahul Srivastava (External)	4/16/26, 11:07:00 AM	rahul.sr@greenkogroup.com				
Purnima Chettri	4/16/26, 11:07:04 AM					
Jayabikash Behera (External)	4/16/26, 11:07:34 AM	jayabikash_ps2609mbh32@iitp.ac.in				
P K PRUSTY E&MR BURLA (Unverified)	4/16/26, 11:08:07 AM					
EEE CRITL BSPTCL (Unverified)	4/16/26, 11:08:57 AM					
CE,CRITL (Unverified)	4/16/26, 11:09:17 AM					
Minhajul Arfin	4/16/26, 11:09:42 AM					
Rajiv Singh CESC (Unverified)	4/16/26, 11:11:05 AM					
Puja Ranjan (Unverified)	4/16/26, 11:13:38 AM					
Bikash Rai	4/16/26, 11:18:20 AM					
ravi ranjan verma	4/16/26, 11:20:22 AM					
upper indravati (Unverified)	4/16/26, 11:21:20 AM					
Ranjan Kumar Biswal {रंजन कुमार बिस्वाल}	4/16/26, 11:22:14 AM	ranjankumar@powergrid.in				
dgm e&mr balangir (Unverified)	4/16/26, 11:23:25 AM					
Roma kumari (Unverified)	4/16/26, 11:24:07 AM					
Anjan Kumar Sahoo (External)	4/16/26, 11:32:16 AM	SAHOOANJANKUMAR@NTPC.CO.IN				
Varish Kumari	4/16/26, 11:34:15 AM					
uihep (Unverified)	4/16/26, 11:43:24 AM					

Samish (External)	4/16/26, 12:02:20 PM	samish@tvnl.in			
S MD RASOOL (External)	4/16/26, 1:10:08 PM	SMDRASOOL@NTPC.CO.IN			



# 157<sup>th</sup> PCC Meeting (16-04-2026)

1



## Protection Performance For The Month Of March 2026

PROTECTION PERFORMANCE

- Total 64-line tripping:
  - Protection operation as per scheme: 38(59%)
  - Protection operation not as desired: 26 (41%)
- Number of Grid Event: GD-1 (2)
  - Generation loss of 50 MW at Rengali PH during GD at TTPS on 12/03/2026.

### Major highlight during April 2026:

- GD-1 reported at 220kV Bidhannagar, DPL and AB Zone on 02/04/2026 due to **unintended switching operation of Bidhannagar ICT-2**. Generation loss of 413 MW at DPL and load loss of 782 MW reported
- GD-1 reported at JSPL and ACPP-II on 06/04/2026 due to unwanted line tripping in Z-4 protection. Total generation loss of 400 MW at ACPP-II and 390 MW at JSPL (Net load loss of 650 MW).

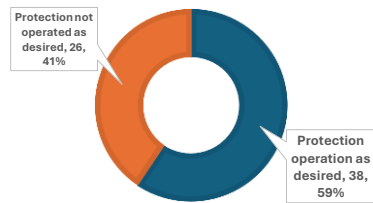

### Protection not operated as desired

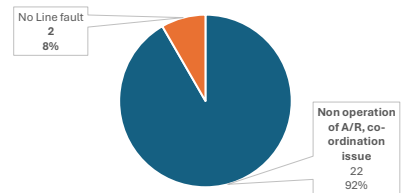

■ Non operation of A/R, co-ordination issue ■ No Line fault

2

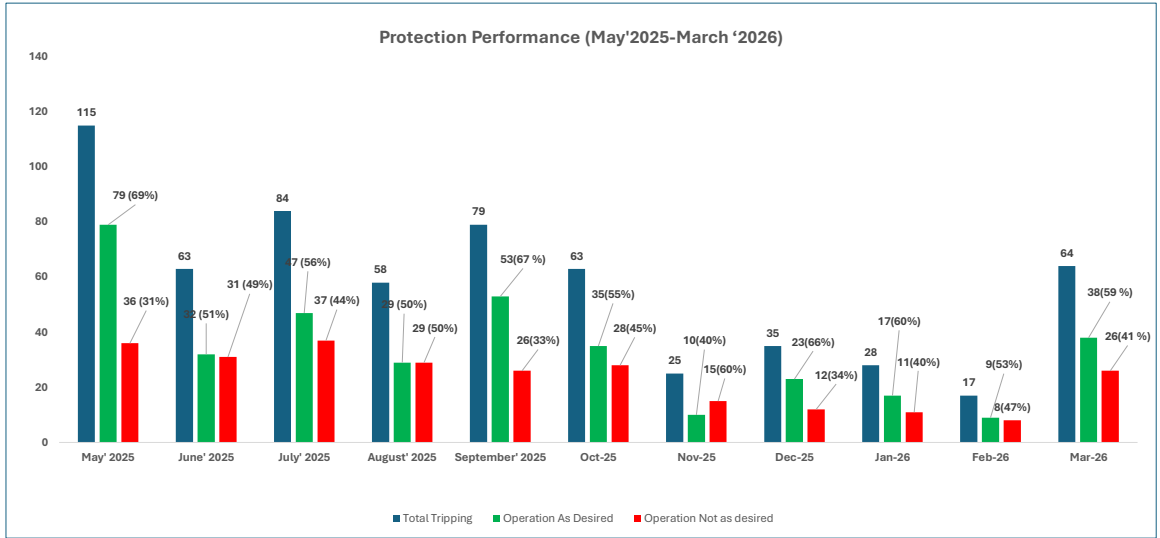

3

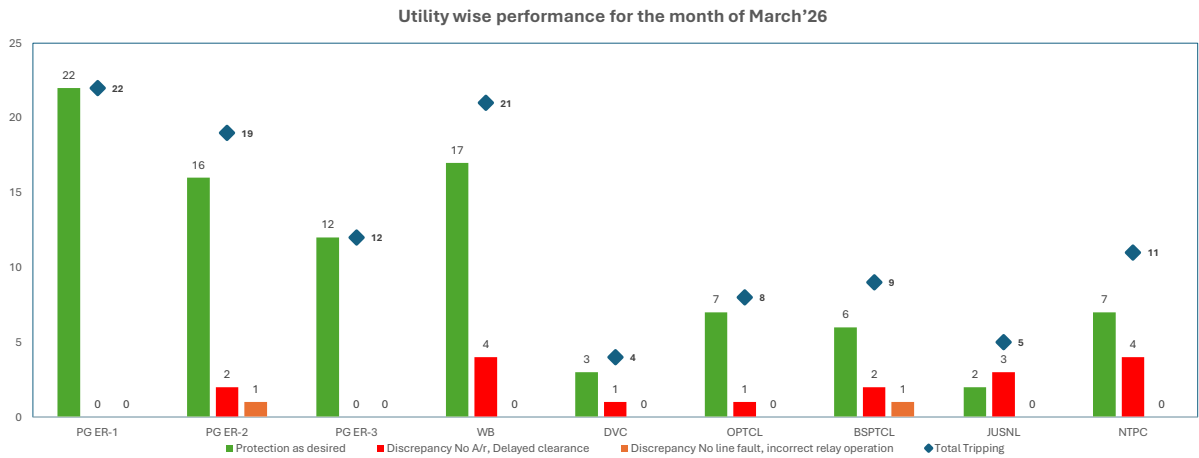

4



ग्रिड-इंडिया  
GRID-INDIA

ग्रिड कंट्रोलर ऑफ इंडिया लिमिटेड  
(भारत सरकार का उद्यम)  
GRID CONTROLLER OF INDIA LIMITED  
(A Government of India Enterprise)



[formerly Power System Operation Corporation Limited (POSOCO)]

पूर्वी क्षेत्रीय भार प्रेषण केन्द्र / Eastern Regional Load Despatch Centre

कार्यालय : 14, गोल्फ क्लब रोड, टॉलीगंज, कोलकाता - 700033  
Office : 14, Golf Club Road, Tollygunge, Kolkata - 700033

CIN : U40105DL2009GOI188682, Website : www.erldc.in, E-mail : erldcinfo@grid-india.in, Tel.: 033 23890060/0061

**पूर्वी क्षेत्र के 220 TTPS में ग्रिड घटना पर विस्तृत रिपोर्ट / Detailed Report of grid event at 220/132  
kV TTPS S/s S/s of Eastern Region  
(To be submitted by RLDC/NLDC during Grid Disturbances/Grid Incidents/Near Miss Event as  
per IEGC section 37.2 (f))  
(आई ई जी सी 37.2 (एफ) के अनुपालन में)**

Date(दिनांक): 20-03-2026

**1. Event Summary (घटना का सारांश):**

**Event on 12-03-2026:**

At 06:36 Hrs on 12/03/2026, R-phase to Y-phase fault occurred in 220kV-TTPS-TSTPP line and fault was cleared from TSTPP end only. Subsequently after 250 msec, LBB operated at TTPS end. Due to LBB operation, all emanating feeders from TTPS end tripped, as they are connected through a single bus arrangement, leading to complete outage of the 220 kV TTPS substation.. At the same time Rengali PH unit-1 also tripped in generator REF protection.. Total generation loss of 50 MW reported at Rengali PH.

**Event on 14-03-2026:**

At 04:23 Hrs on 14/03/2026, B-phase to earth fault occurred in 220kV-TTPS-TSTPP line and fault was cleared from TSTPP end only. Due to non-opening of CB at TTPS end, LBB operated and tripped all emanating feeders from TTPS end (All feeders are connected through single bus arrangement), leading to complete outage of 220 kV TTPS S/s.

**2. Time and Date of the Event (घटना का समय और दिनांक):**

Event-1: At 06:36 Hrs on 12/03/2026

Event-2: At 04:23 Hrs on 14/03/2026

**3. Event Category (ग्रिड घटना का प्रकार): Grid Disturbance (GD)-1**

**4. Location/Control Area (स्थान/नियंत्रण क्षेत्र): Odisha**

### 5. Antecedent Conditions (पूर्ववर्ती स्थिति):

#### Event-1: At 06:36 Hrs on 12/03/2026

	Frequency in Hz	Regional Generation in MW	Regional Demand in MW	State Generation in MW	State Demand in MW
				Odisha	Odisha
Pre-Event (घटना पूर्व)	49.96 Hz	33715 MW	23007 MW	4037 MW	4770 MW
Post Event (घटना के बाद)	49.96 Hz	33755 MW	23102 MW	3972 MW	4770 MW

#### *Pre and post data of 1 minute before and after the event*

Important Transmission Line/Unit if under outage (महत्वपूर्ण संचरण लाइने/ विद्युत उत्पादन इकाइयां जो बंद हैं)	NIL
Weather Condition (मौसम स्थिति)	Normal.

#### Event-2: At 04:23 Hrs on 14/03/2026:

	Frequency in Hz	Regional Generation in MW	Regional Demand in MW	State Generation in MW	State Demand in MW
				Odisha	Odisha
Pre-Event (घटना पूर्व)	49.859 Hz	32134 MW	23547 MW	3846 MW	4925 MW
Post Event (घटना के बाद)	49.859 Hz	32132 MW	23548 MW	3847 MW	4925 MW

#### *\*Pre and post data of 1 minute before and after the event*

Important Transmission Line/Unit if under outage (महत्वपूर्ण संचरण लाइने/ विधुत उत्पादन इकाइयां जो बंद है)	220/132 kV ATR-1 at TTPS
Weather Condition (मौसम स्थिति)	Normal.

**6. Load and Generation loss (लोड और जेनरेशन हानि):**

**Event-1: At 06:36 Hrs on 12/03/2026:** Generation loss-50 MW at Rengali PH, Load loss-Nil

**Event-2: At 04:23 Hrs on 14/03/2026:** Generation loss- NIL, Load Loss-Nil

**7. Duration of interruption (रूकावट की अवधि):**

**Event-1: At 06:36 Hrs on 12/03/2026:** 06:28 Hrs (06 Hours and 28 Minutes)

**Event-2: At 04:23 Hrs on 14/03/2026:** 01:39 Hrs (01 Hours and 39 Minutes)

**8. Network across the affected area (प्रभावित क्षेत्र का नक्शा):**

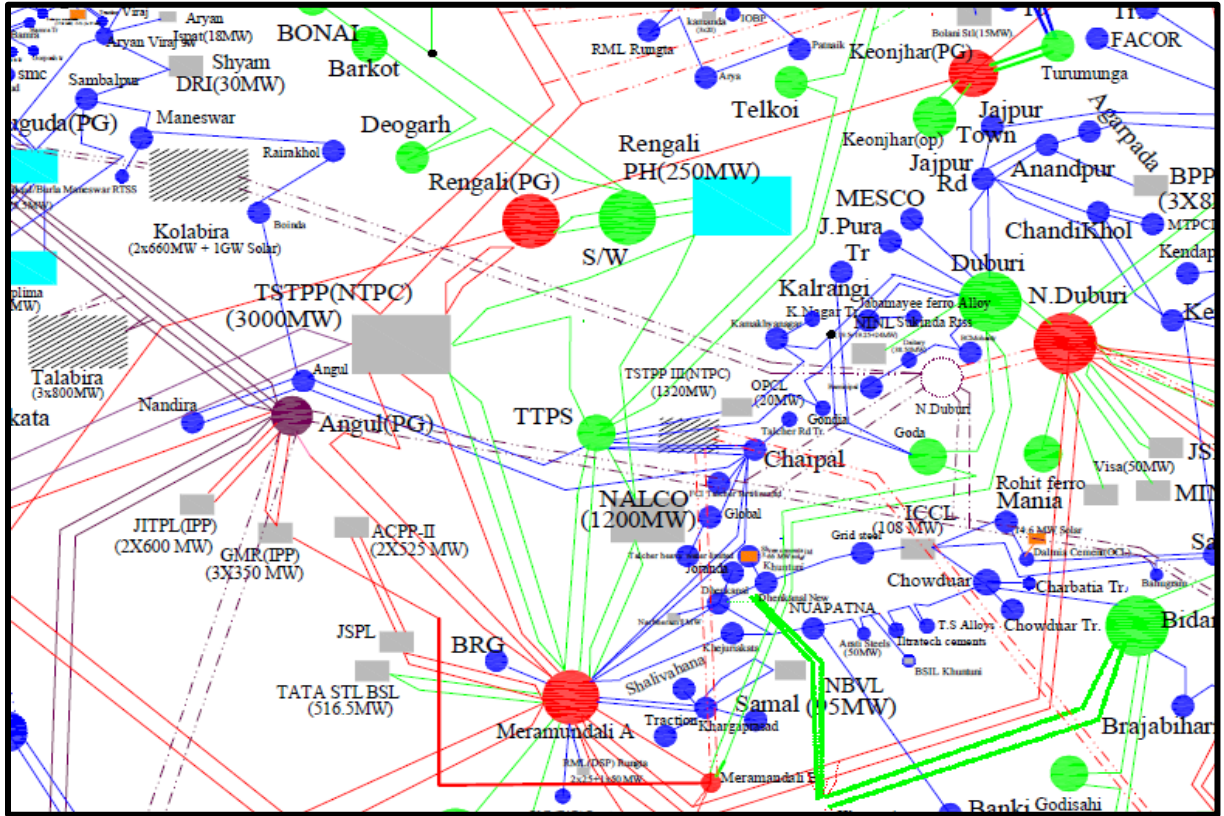

**Figure 1: Network across the affected area**

**9. Details of Equipment Failure (if any during the event) (उपकरण विफलता का विवरण): NIL**

**10. Major Elements Tripped (प्रमुख ट्रिपिंग):**

**Event-1: At 06:36 Hrs on 12/03/2026**

क्र०स०	नाम	Trip time (hh:mm:ss)	उप केंद्र 1 रिले संकेत	उप केंद्र 2 रिले संकेत
1	220 kV TTPS-TSTPP	06:36	LBB operated at TTPS	Distance protection operated
2	220 kV TTPS-NALCO			-
3	220 kV TTPS-Meramundali D/c			-

4	220 kV TTPS-Joda			-
5	220 kV TTPS-Telkoi			-
6	2*220/132 kV 160 MVA ATR at TTPS			-
7	220 kV Rengali PH-NALCO	06:36	Distance protection operated	-
8	220 kV Rengali PH-TSTPP		Distance protection operated	-
9	50 MW U#1 at Rengali PH		GT REF operated	-

**Event-2: At 04:23 Hrs on 14/03/2026**

क्र०स०	नाम	Trip time (hh:mm:ss)	उप केंद्र 1 रिले संकेत	उप केंद्र 2 रिले संकेत	Restoration time (Hrs)
1	220 kV TTPS-TSTPP	04:23:	LBB operated at TTPS	Distance protection operated	-
2	220 kV TTPS-NALCO			-	06:19
3	220 kV TTPS-Meramundali -1			-	06:02
4	220 kV TTPS-Joda			-	06:29
5	220 kV TTPS-Telkoi			-	06:24
6	220/132 kV 160 MVA ATR -2 at TTPS			-	06:11
7	220 kV TTPS-Meramundali -2			-	06:06

11. Event Analysis (Based on PMU, SCADA & DR) (घटना का विश्लेषण):

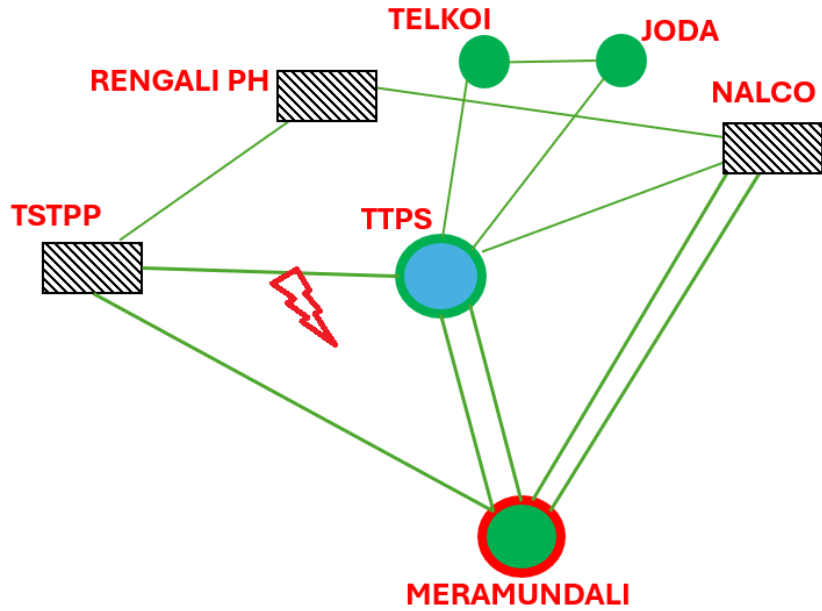

**Event-1: At 06:36:36 Hrs on 12/03/2026:**

- At 06:36:36 Hrs on 12/03/2026, Z-1, Y\_B phase fault occurred in 220kV TSTPP-TTPS line and fault was cleared within 80 msec from TSTPP end only.
- At the same time, 220kV Rengali PH-TSTPP line, 220kV Rengali PH-NALCO line and Rengali unit#1 also tripped in distance protection and generator REF protection respectively.
- During opening of CBs for 220kV TSTPP-TTPS line at TTPS end, B-pole CB got stuck, which led to LBB initiation and after 200 msec LBB operated at TTPS S/s.
- All connected feeders at TTPS got tripped due to LBB operation. (All elements kept on single bus).
- 220kV\_TTPS S/s became dead, and 50 MW generation loss reported at Rengali PH.

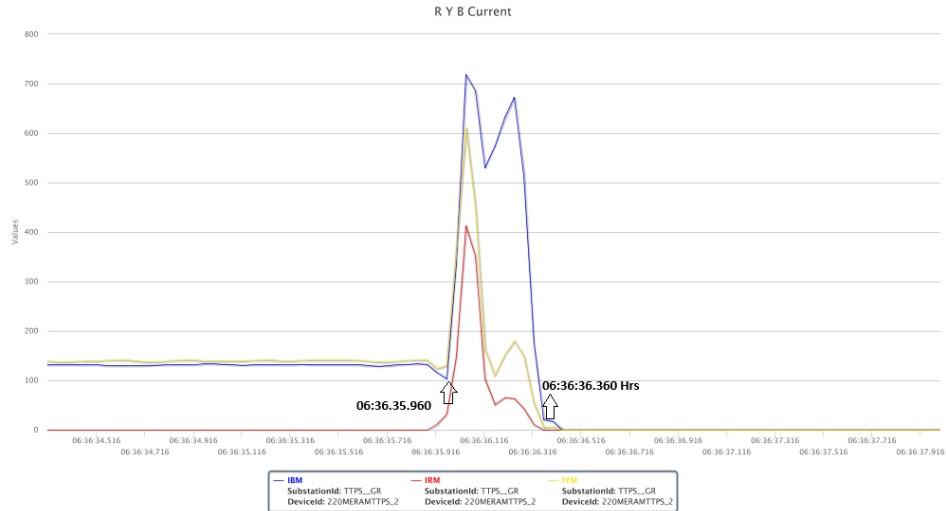

**PMU of current in TTPS Meramundali at TTPS**

**Event-2: At 04:23 Hrs on 14/03/2026:**

- At 04:23:02 Hrs on 04/03/2026, R-Y phase fault occurred in 220kV TTPS-TSTPP line and fault sensed in Z-1 protection from both end and line got tripped within 80 msec from TSTPP end.
- During tripping at TTPS end, B pole CB got stuck at TTPS end which led to LBB initiation and after 200 msec LBB operated at TTPS end.
- All elements connected to TTPS got tripped due to LBB operation at TTPS end (All feeders kept on single bus).
- 220kV TTPS S/s became dead. No load and No generation loss reported at TTPS S/s.

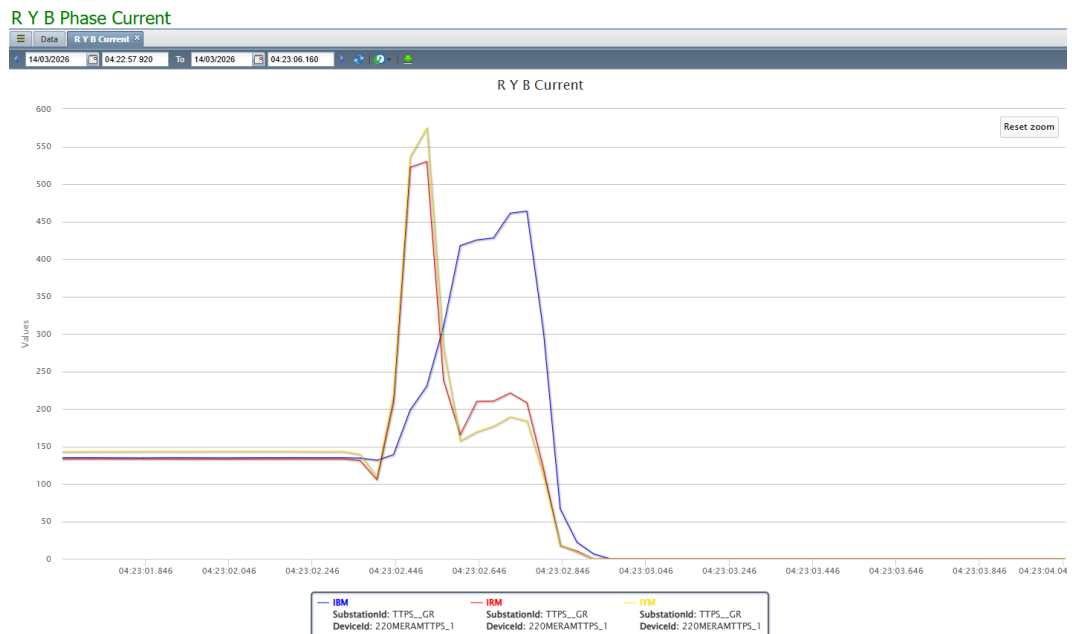

**PMU of current in TTPS Meramundali at TTPS**

## 12. Protection/Operational issues observed (सुरक्षा/परिचालन संबंधी समस्या):

- Reason of non-opening of B phase CB at TTPS end for 220kV TTPS-TSTPP line may be investigated and shared.
- Reason of unwanted tripping of 220kV Rengali-TSTPP, Rengali NALCO and Rengali unit-1 may be examined and furnished.
- It is requested to **explore distribution of feeders across both 220 kV buses with Bus coupler ON**, so that feeders connected to the other bus can remain in service in the event of LBB/BB protection operation.
- Preventive maintenance of Circuit breaker may be ensured in line with CEA Grid Standard Regulation 2010

## 13. Action Taken/Remedial Measures (सुधारात्मक उपाय): NIL

## 14. Non-compliance observed (विनियमन का गैर-अनुपालन):

S.No.	Issues	Regulation Non-Compliance	Remark
1	Flash Report received within 8hrs?	IEGC section 37.2 (b)	Not Submitted
2	Whether DR/EL provided within 24 Hours?	1. IEGC section 37.2 (c) 2. CEA grid Standard 15.3	Submitted (After 24 Hrs)
3	Detailed Report received within 7 days?	IEGC section 37.2 (e)	Not Submitted
4	Protection system not operated correctly	CEA Technical Standard for Construction of Electrical Plants and Electric Lines: 48 (1) a. CEA (Technical standards for connectivity to the Grid) Regulation, 2007: Schedule Part 1. (6.1, 6.2, 6.3)	Unwanted tripping of Rengali-TSTPP, Rengali-NALCO and Rengali PH unit-1

## 15. Key Lessons Learnt (प्रमुख अधिगम बिंदु):

### Annexure-1:

**Incident 1 (Background):**

Simultaneous Tripping of 4 Nos. circuits i.r.o. 132KV BTPS-Bighati 1 & 2 and 132KV BTPS - Chanditala 1 & 2 on 05.04.25 whereas no tripping occurred at far end S/S.

Relay details are as follows:

SI No	Date	T.O.O.	Feeder/Gen	Relay Details BTPS End	Relay Detail Far End
1	05.04.25	21:38 Hrs	132kV Chanditala Ckt#1	Z-3, Dist. 50.74 Km., IA-865.2 A, IB- 915.6 A, IC-911.2 A, PSB optd.,	No tripping occurred
2	05.04.25	21:38 Hrs	132kV Chanditala Ckt#2	Z-3, Dist. 49.68 Km., IA-885.4 A, IB- 936.8 A, IC-930.0 A, PSB optd.,	No tripping occurred
3	05.04.25	21:38 Hrs	132kV Bighati Ckt#1	Back up over current, Ia=495 A, Ib=520 A, Ic=519 A, 1 sec	No tripping occurred
4	05.04.25	21:38 Hrs	132kV Bighati Ckt#1	Back up over current, Ia=761 A, Ib=784 A, Ic=792 A, 0.8 sec	Loss of voltage, General protection Trip

As per information received from 220 KV Rishra substation, **Busbar Differential Protection operated at Rishra 220 KV Main Bus 1 & 2 during that time.** Also, neither 132 KV Rishra-Bighati nor 132 KV Rishra-Chanditala Tripped at Rishra end at that time.

**Incident 2 (Subsequent Occurrence):**

Again, simultaneous tripping observed i.r.o. 132KV BTPS - Adisaptagram Double Ckt at BTPS end on 01.09.25 with distance protection operated due to B-phase PT burst incident at the far end substation **but no tripping occurred at far end S/S.**

Relay details are as follows:

SI No	Date	T.O.O.	Feeder/Gen	Relay Details BTPS End	Relay Detail Far End
1	01.09.25	05:36 Hrs	132 kV Adisaptagram # 1	Fault Zone: Z-2 Fault Distance: 9.444 Km Fault Current: 6.060 Ka Fault Phase: R-Y-B Phase	No tripping occurred
2	01.09.25	05:36 Hrs	132 kV Adisaptagram # 2	Fault Zone: Z-2 Fault Distance: 9.534 Km Fault Current: 6.016 Ka Fault Phase: R-Y-B Phase	No tripping occurred

At U#5 Generator Relay Protection (GRP) Panel:

- Differential Protection Pickup
- O/C Protection Pickup
- Negative Phase Sequence Pickup

### Incident 3 (Most Recent):

Further, recently on 30.03.26, BTPS - Chanditala Double Ckt tripped at BTPS end only due to occurrence of Bus fault at 132kV Chanditala end. **However, no tripping occurred at far end S/S.**

Relay details are as follows:

SI No	Date	T.O.O	Feeder/Gen	Relay Details BTPS End	Relay Detail Far End
1	30.03.2026	05:20 Hrs	132kV Chanditala Ckt#1	FAULT ZONE: Z-2 FAULT DISTANCE: 40.6 KM FAULT CURRENT: 2.097 KA FAULT PHASE: R PHASE	No tripping occurred
2	30.03.2026	05:20 Hrs	132kV Chanditala Ckt#2	FAULT ZONE: Z-2 FAULT DISTANCE: 39.52 KM FAULT CURRENT: 2.150 KA FAULT PHASE: R PHASE	No tripping occurred

Annexure 2.3

# Tripping of 220 kV Bus at Khagaul S/s due to LBB Operation

- ▶ DATE AND TIME : 16.03.2026, 13:39 hrs
- ▶ 220 kV Naubatpur-Khagaul Ckt-2 tripped due to snapping of conductor.
- ▶ R-PHASE CONDUCTOR SNAPPED

1

2

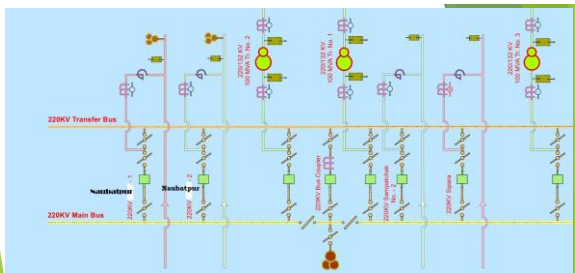

220kV Ara PG - Khagaul line LIL0 at Naubatpur - Line Maintained by PGCIL

3

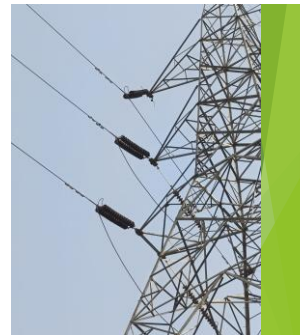

4

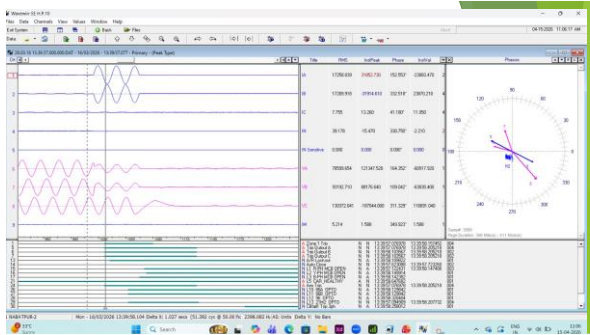

5

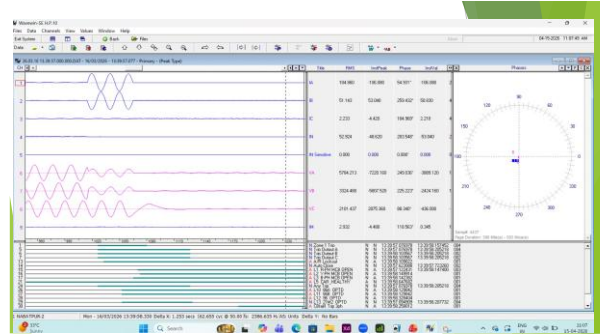

6

- ▶ LBB SETTING 100 mA (CTR 800/1)
- ▶ Fault current in R phase after 3-Ph tripping was more than 80A
- ▶ LBB operated leading to 220kV elements tripping
- ▶ Power at 132kV maintained via 132kV Bihta D/c lines

7

- ▶ Remedial Action:
- ▶ LBB setting of all bays rechecked and revised
- ▶ Working agency of SAS work scheduled to visit for thorough rechecking of LBB/BB configuration/Termination of wires/settings.

8



➤ **Fault conditions :-**

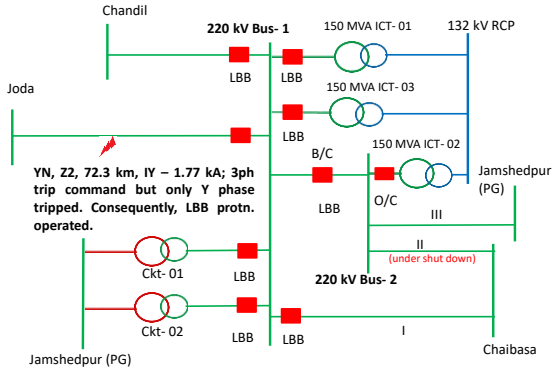

5

• **Relay Indications:-**

Element's Name	Relay End-1	Relay End-2	Remarks
220 kV RCP - Joda	YN, Z2, 72.3 km, IY - 1.77 kA. LBB protn. operated.		3ph trip command but only Y phase tripped.
220 kV RCP - Chandil	LBB	Didn't Tripped	
220 kV RCP - CBSA-01	LBB	Didn't Tripped	
220 kV RCP - JSR (PG) - 01 & 02	LBB		
220 kV RCP - JSR (PG) - 03	Didn't Tripped		
220 kV Bus Coupler	LBB		
150 MVA, ICT - 01 & 03	LBB		
150 MVA, ICT - 2	O/C		

6

**Relay Indication :-**

Number	Indication	Value	Date and time	Cause	State
00301	Power System fault	165 - ON	04-04-2026 12:04:46.189		
00302	Fault Event	165 - ON	04-04-2026 12:04:46.189		
07165	50(N)S1(N) Backup O/C PICKUP GROUND	ON	0 ms		
07171	50(N)S1(N)-B Pickup - Only GROUND	ON	0 ms		
07192	50(N)-B2 Pickup	ON	0 ms		
07193	51(N)-B Pickup	ON	200 ms		
07193	50(N)S1(N) Backup O/C PICKUP Phase B	ON	380 ms		
07175	50(N)S1(N)-B Pickup BG	ON	380 ms		
07191	50(N)-B1 Pickup	ON	390 ms		
03684	21 Pickup BG	ON	406 ms		
03702	21 Selected Loop BCG forward	OFF	440 ms		
00805	21 TRIP command Phases ABC	ON	426 ms		
00536	Relay Defensive TRIP	ON	426 ms		
00533	Primary fault current Ia	0.38 kA	429 ms		
00534	Primary fault current Ib	1.77 kA	429 ms		
00535	Primary fault current Ic	0.34 kA	434 ms		
01461	50BF Breaker failure protection started	ON	420 ms		
07171	50(N)S1(N)-B Pickup - Only GROUND	ON	460 ms		
01476	50BF Local Trip - ABC	ON	629 ms		
01494	50BF Breaker trip	ON	629 ms		
01468	50BF Breaker failure A	ON	629 ms		
01468	50BF Breaker failure C	ON	629 ms		
01469	50BF Breaker failure 3IO	ON	629 ms		
01461	50BF Breaker failure protection started	OFF	694 ms		
03671	21 PICKED UP	OFF	695 ms		
03702	21 Selected Loop BCG forward	OFF	695 ms		
07161	50(N)S1(N) Backup O/C PICKED UP	OFF	700 ms		
01468	50BF Breaker failure C	OFF	729 ms		
01469	50BF Breaker failure 3IO	OFF	729 ms		
00511	Relay GENERAL TRIP command	OFF	729 ms		
01134	Fil Locator: Loop BG	ON	440 ms		
01117	Fil Locator: secondary RESISTANCE	10.51 Ohm	440 ms		
01118	Fil Locator: secondary REACTANCE	8.66 Ohm	440 ms		
01114	Fil Locator: primary RESISTANCE	35.05 Ohm	440 ms		
01115	Fil Locator: primary REACTANCE	28.87 Ohm	440 ms		
01119	Fil Locator: Distance to fault	72.3 km	440 ms		
01120	Fil Locator: Distance [%] to fault	55.6 %	440 ms		

7

• **Tripping Analysis :-**

❖ There was YN, Z2 fault ( ) in 220 kV Ramchandrapur - Joda s/c and 3 ph trip command issued but only Y-ph tripped. With tripping of Y phase line fault was got cleared but other two phase current remain above Breaker Failure threshold current of 120 A. Consequently, after 200 ms LBB protection operated.

❖ This results tripping of all elements of Main Bus - 1 on LBB protection and due to which main bus - 01 became dead.

❖ 150 MVA, 220/132 kV ICT - 02 tripped on O/C due shifting of all downstream (132 kv) loads to this ICT.

8

**Protection Issue observed during the event:-**

- Tripping circuit of 220 kV Ramchandrapur – Joda s/c was not operated as desired.

9

**• Remedial Measures:-**

There was vegetation issue in the line between tower loc no – 180 to 181 and which has been cleared on 05.04.26.

10

**• Restoration of elements:-**

Sl. No.	Element's Name	Restoration Time
1	220 kV Ramchandrapur - Chandil	14:20 hrs
2	220 kV Ramchandrapur – Chaibasa - 01	
3	220 kV Ramchandrapur – Jamshedpur (PG)- 01 & 02	14:17 hrs
4	220 kV Ramchandrapur – Joda	15:17 hrs (05.04.26)
5	220 kV Ramchandrapur – Jamshedpur (PG)- 02	19:27 hrs (15.09.25)
6	150 MVA ICT – 01, 02 & 03	

11

## List of important transmission lines in ER which tripped in March-2026

Sl. No.	LINE NAME	TRIP DATE	TRIP TIME	Relay Indication LOCAL END	Relay Indication REMOTE END	Remarks	LOCAL END UTILITY	REMOTE END UTILITY	UTILITY RESPONSE
1	400KV-NEW JEERAT-SUBHASGRAM(PG)-1	28-03-2026	00:24	Jeerat: R-E, 80km, 4kA	Subhasgram: R-E, 37.51 km, 9.88 kA	A/r failed after 1 sec.	PMJTL	PG ER-II	A/R attempted & line tripped due to persisting fault. Protection operated properly at PG ER-II end.
2	400KV-BINAGURI-NORBUGANG-1	30-03-2026	12:55	R/I at Binaguri: R_N, FC 3.3 kA, FD 109.16 km [Fault in Bhutan jurisdiction]		Line tripped in reclaim time from Binaguri end and three phase tripping for phase to ground fault from Bhutan end.	PG ER-II	BHUTAN	A/R was successful through main & tie CB. However, fault occurred again after 2.45 sec & line tripped due to fault within reclaim time. Protection operated properly at PG ER-II end.
3	400KV-DURGAPUR-JAMSHEDPUR-1	30-03-2026	20:51	Jamsedpur: DT received	-	Line tripped from Jamshedpur end due to DT received. PG ER-II may explain.	PG ER-II	PG ER-I	Fault occurred in age-old cable & DT sent. The cable has been replaced & issue rectified.
4	400KV-ALIPURDUAR (PG)-JIGMELLING-2	19-03-2026	08:15	Alipurduar Y_N , 56.7 KM , 5.2 KA ,	Jigmeling - Phase to ground fault, Zone 1, Dist=113.7km.	A/r failed after 1 sec	PG ER-II	BHUTAN	A/R attempted & line tripped due to persisting fault. Protection operated properly at PG ER-II end.
5	220KV-MAITHON(PG)-DUMKA-1	18-03-2026	17:28	Maithon: B-N, 60.22km, 2.94kA	Dumka: 6.041KA, Zone1, Dist-1.36km	Three phase tripping for phase to ground fault from Dumka end and Z-2 tripping from Maithon end. JUSNL and PG ER-2 may explain.	PG ER-II	JUSNL	Fault was single phase type & detected in Z2 at Maithon end. However, carrier was not received from Dumka end. Hence, 3 phase delayed trip occurred in Z2 after T2.
6	400KV-ALIPURDUAR (PG)-BONGAIGAON-1	17-03-2026	21:54	R/I at Alipurduar End: Y-ph, FD:10.7 Km, FC:11.626 kA;	Bongaigaon : Y-N, Z2 , FD 102.8 km, FC 2.6 kA	A/r failed after 1 sec.	PG ER-II	NORTH_EAST REGION	A/R attempted & line tripped due to persisting fault. Protection operated properly at PG ER-II end.
7	400KV-BINAGURI-NORBUGANG-1	17-03-2026	19:01	Binaguri end: Y-N, 118.5km, 3.023kA;	Norbugang : Y_N, Zone 1 optd, Dist=4.483km, Iy=4.114kA, Conductor snapping reported under Bhutan jurisdiction	A/r failed after 1 sec.	PG ER-II	BHUTAN	A/R attempted & line tripped due to persisting fault. Protection operated properly at PG ER-II end.
8	400KV-BINAGURI-TALA-1	16-03-2026	22:55	DT received at Binaguri	R/I at Tala : Y_N, Fault current Iy=5.99kA, Earth fault	Due to high resistive fault, line tripped from Bhutan end on DEF protection and DT send to remote end. At PG end, reason of no protection picked up may be explain while natural current was around 500 A during the fault event.	PG ER-II	BHUTAN	Fault was very high resistive in nature with very less reduction in faulty phase voltage. Only DEF started at Binaguri end. Further, DT received from Bhutan end & trip occurred at Binaguri end. Protection operated properly at PG ER-II end.
9	400KV-DURGAPUR-KHSTPP-1	15-03-2026	20:13	DURGAPUR: FD: 205 KM , 2.03 KA , Y-N	KAHALGAON- MI- FD-70.74KM, F.C-3.941KA, Y-N	Line tripped in reclaim time.	PG ER-II	NTPC	A/R was successful through main & tie CB. However, fault again occurred after 7.3s & three phase trip happened due to fault within reclaim time. Protection operated properly at PG ER-II end.
10	400KV-ALIPURDUAR (PG)-BINAGURI-3	14-03-2026	06:07	Alipurduar: Over Voltage Protection operated	Binaguri: DT received	Sudden High positive drift voltage( more than 13kV) deviation observed in Y-Phase of Binaguri -Alipurduar Ckt-3 CVT at Alipurduar which led to tripping on O/V protection. PG ER-II may explain.	PG ER-II	PG ER-II	There was no actual system overvoltage. Sudden overvoltage observed in Y phase only due to CVT issue. CVT has been replaced.
11	765KV-MEDINIPUR-NEW JEERAT-2	13-03-2026	19:29	Medinipur: R-Y, FD:164 Km, Ir:4.71 kA, Iy:4.62 kA	New Jeerat end: R-Y, FD::2.5 Km, Ir:7.61 kA, Iy:7.885 kA	Line tripped on phase to phase fault.	PG ER-II	PG ER-II	Phase to phase fault detected & 3 phase trip happened. Protection operated properly at PG ER-II end.
12	400KV-BINAGURI-NORBUGANG-1	01-03-2026	23:03	R/I at Binaguri: R_Y_N, Fault distance 129.2 km, Fault Current Ir 5.407 kA, Iy 3.131 kA	Norbugang :Y_N, Fault Current Iy=2.189kA, Fault distance= 40.03km	A/r failed after 1 sec.	PG ER-II	BHUTAN	A/R was successful through main CB. However, fault again occurred at 1.58s & three phase trip happened. Protection operated properly at PG ER-II end.

Sl. No.	LINE NAME	TRIP DATE	TRIP TIME	Relay Indication LOCAL END	Relay Indication REMOTE END	Remarks	LOCAL END UTILITY	REMOTE END UTILITY	UTILITY RESPONSE
13	400KV-BINAGURI-NORBUGANG-1	01-03-2026	20:19	A/R successful at Binaguri end: R_N, Fault distance 122.3 km, Fault Current 2.921 kA	Tripped at Norbugang end, R/I at Norbugang : R_N,Fault Current 2.835kA	A/r successful from Binaguri end and line tripped from Bhutan end.	PG ER-II	BHUTAN	A/R was successful at Binaguri end. Protection operated properly at PG ER-II end.
14	400KV-BINAGURI-TALA-2	01-03-2026	18:06	Binaguri: Y-ph, Z-II, 132.8 km, 2.969kA	-	Line tripped from Binaguri end in Z-2 protection due to carrier not received at PG end.	PG ER-II	BHUTAN	Fault was single phase type & detected in Z2 at Binaguri end. However, carrier was not received from Bhutan end. Hence, 3 phase delayed trip occurred in Z2 after T2.
15	220KV-KARAMNASHA (NEW)-SAHUPURI-1	27-03-2026	23:08	Karamnasa: Z-2, R_B fault, FC- IR-4.2KA, IB-4.8 KA, FD-41.48 KM	Sahupuri: Z-1, FC-IR-2.8KA, IB-1.93KA, FD-3.125 KM	Line tripped in Z-2 protection from Karamnasha end and in Z-1 protection from NR end.	BSPTCL	NORTHERN REGION	As reported, PLCC Unhealthy at Sahpuri end.
16	220KV-KARAMNASHA (NEW)-SAHUPURI-1	21-03-2026	01:13	Karmanasa: Ir- 4.54 kA , Ib-4.54 KA ,Zone -2 Distance -41.6 km	Sahupuri end: Zone 1,R_B phase , Dist= 3.189Km,Ir=1.57 kA,Ib = 1.261 kA.	Line tripped in Z-1 protection from Sahupuri end and in Z-2 protection from Karamnasha end. BSPTCL may explain.	BSPTCL	NORTHERN REGION	As reported, PLCC Unhealthy at Sahpuri end.
17	220KV-KHAGARIA-NEW PURNEA-1	20-03-2026	21:11	Khagaria: Distance Protection Relay Main-1&2, B ph, Zone-1, Distance - 65.51km, Ir-159A, Iy-291.1A,Ib-2.344kA Vr-131.5kV, Vy-133.6kV, Vb-96.14kV.	New Purnea: B-Ph, 38.2km, 5.67kA;	A/r successful from Purnea end and A/r failed from Khagaria end.	BSPTCL	PG ER-I	Generally A/R takes palces at Khagaria new end also. But on this date A/R did not take place, A/R occured on later date-24/03/26.
18	400KV-BARH-BAKHTIYARPUR(BH)-2	20-03-2026	20:35	Barh: DT Received	-	Line tripped due to DT received at Barh, BSPTCL may explain.	NTPC	BSPTCL	DT send to Barh end due to Manual opeartion of Tie CB.
19	400KV-BARH-BAKHTIYARPUR(BH)-2	20-03-2026	19:25	BARH-FD-4.2KM FC - 28.35KA	BAKHTIYARPUR-FD-36.03KM FC-4.18KA;	Three phase tripping from both end and after 2 sec of tripping CB close at BSPTCL end. BSPTCL may explain.	NTPC	BSPTCL	At present , Bay is under the scope of executing agency. The issue has been communicated for early rectification.

Follow-Up Compliance for Disturbance at 220 kV Begusarai (BSPTCL) S/s on 06.02.2026 at 09:35 Hrs

PCC Recommendation	BSPTCL Compliance
<p>Thermo-vision scanning of all jumpers, connectors, clamps shall be carried out to identify hotspots or loose joints, and remedial measures shall be taken in case any abnormalities found. Further the jumper/Connectors which are old shall be replaced to avoid recurrence of such incidents.</p>	<p>Instruction Conveyed to Field Authorities for Strict Compliance.</p>
<p>Definite time overcurrent protection &amp; Undervoltage protection present in 220 kV IOCL feeder at IOCL end shall be disabled immediately.</p>	<p>Regarding this Mail has been sent to IOCL Barauni from EEE/TD/Begusarai on date-17/03/26 for their opinion and further needful but till date, no any correspondence has been received from IOCL end.</p>
<p>All feeders shall be segregated uniformly among the two bus of 220 kV Begusarai S/s and highset overcurrent E/f settings is to be enabled in B/C Bay to avoid complete blackout of the substation in absence of busbar protection.</p>	<p>All feeders segregated uniformly among the two bus of 220 kV Begusarai S/s on date-15/04/26 and highset overcurrent E/f settings in B/C Bay enabled.</p>
<p>The zone-4 settings of 220 kV Saharsa-1 Line may be rechecked as the trip was issued within 250 msec even though the Zone-4 signal went low intermittently for 112 msec after the first start.</p>	<p>The zone-4 settings of 220 kV Saharsa-1 Line rechecked and compared with zone-4 settings of 220 kV Saharsa-2 Line (which operated correctly during the event). The setting found Ok and is under observation.</p>



# JHARKHAND URJA SANCHARAN NIGAM LIMITED

(CIN No. - U40108JH2013SGC001704)

Regd. Office - SLDC Building, Kusai Colony, Doranda, Ranchi - 834 002

Website: www.jusnl.in, Email: cecri@rediffmail.com

Letter No .....94..... /Ranchi

Dated.....08/04/2026.....

From,

**General Manger (CRITL/ O.E)**  
Kusai Colony, Ranchi

To,

**ERPC Protection Team, Kolkata**

**ERLDC Protection Team, Kolkata**

**Sub:- Regarding restoration of 400 kV Busbar Protection at 400/220 kV Patratu S/s.**

Ref :- Item No 3.4.2 of Minutes of 155<sup>th</sup> PCC meeting (Follow -up of 154<sup>th</sup> PCC)

Sir,

With reference to above, the 400 kV Busbar protection at 400/220 kV Patratu substation is restored after rectification of circuitry discrepancies of CT secondary connections and Logic configuration of Busbar relay.

Following rectification work has been carried out: -

Date : 22.01.2026

1. CT input configured in PU relays as per CT field connection of Bay's 413, 415, 416 & 418 bays along with busbar protection core of CT changed to 2000/1 as per busbar base current value.
2. CT supervision & Zero cross supervision setting has been enabled.
3. Soft logic has been reviewed and modified as per scheme drawing.

Date : 21.02.2026

1. Bay testing & Circuitry issue rectification of Bay no 413 (400 kV PVUNL - 02) has been done along with busbar protection core of CT changed to 2000/1 as per busbar base current value.

Date : 26.02.2026

1. Soft logic for tripping of Tie Bay's has been removed by Siemen's engineer.

Date : 01.04.2026 to 03.04.2026

1. Bay checking and testing of 400 kV PVUNL - 01 (416 bay) is done. During Primary Injection testing abnormal current value observed in PU - 2 (87BB2) and after thorough checking it is found that relay CT star point was incorrect, same has been rectified.
2. After that all PU's (87BB relay's) relay CT star point is checked and during checking incorrect relay CT star point found in PU - 1 & 2 of 400 kV Latehar -1 (401) bay, PU - 1 of 400 kV Latehar - 02 (404) bay and PU - 2 of 400 kV PVUNL - 02 (413) bay same has also been rectified.

3. After above rectification work, Bus Stability test has been carried out in reference to 400 kV PVUNL – 02 (413 bay) to all other 400 kV Bays (400 kV Latehar -1 & 2, 400 kV New Ranchi (Bero) -1 & 2 and 400 kV PVUNL – 01) and some other circuitry issues are found which has also been checked & rectified and after its rectification, Busbar found STABLE.
4. After charging of all element of 400 kV Main Bus -1, Differential Current and Stabilizing Current of Main and Check Zones are closely monitored and found stable & balanced.
5. Differential Current and Stabilizing current of Main and Check Zones of Main Bus -2 has also been checked and found normal.
6. After observation around 4 Hrs., 400 kV Busbar Protection is taken into service and accordingly Zone 4 time is reverted to 500 ms of all 400 kV line bays.

(MoM & Test report are attached for reference)

This is for your kind information and necessary action.

**Encl :** As Above

Yours faithfully,

  
08/04/26  
**(Umesh Pd. Singh)**  
General Manager, CRITL/ O.E.