



भारत सरकार / Government of India
विद्युत मंत्रालय / Ministry of Power
पूर्वी क्षेत्रीय विद्युत समिति / Eastern Regional Power Committee

सं /NO. ERPC/EE/OPERATION/2026/177

DATE:24.04.2026

सेवा में /To
संलग्न सूची के अनुसार /As per list enclosed.

विषय :17.04.2026 (शुक्रवार) को ईआरपीसी सचिवालय, कोलकाता में भौतिक रूप से आयोजित 238वीं ओसीसी बैठक के कार्यवृत्त – के संबंध में

Sub: Minutes of 238th OCC Meeting held on 17.04.2026 (Friday) physically at ERPC Secretariat, Kolkata – reg

महोदय/महोदया,
Sir(s)/Madam,

कृपया अपनी जानकारी और आवश्यक कार्रवाई के लिए **17 मार्च 2026 (शुक्रवार)** को आयोजित **238वीं ओसीसी बैठक** के **कार्यवृत्त** संलग्न देखें। यह ईआरपीसी वेबसाइट (www.erpc.gov.in) पर भी उपलब्ध है।
Please find enclosed **Minutes of 238th OCC Meeting** held on **17.04.2026 (Friday)** physically at ERPC Secretariat, Kolkata at 10:30 hrs. This is for your **kind information** and **necessary action**. The same is also available at ERPC website (www.erpc.gov.in).

टिप्पणियाँ, यदि कोई हों, कृपया यथाशीघ्र इस कार्यालय को अग्रेषित करें।
Observations, if any, may please be forwarded to this office at the earliest.

इसे सदस्य सचिव के अनुमोदन से जारी किया जाता है।
This issues with the approval of Member Secretary.

भवदीय /Yours faithfully

(R.K.Meena)
SE(Operation)
एसई (ऑपरेशन)

List of Addressee

Sl.No	Organization	Category	E-mail
1	ERPC	ERPC	mserpc-power@nic.in
2	ERPC		secomml.erpc@gov.in
3	ERPC		seop-erpc@gov.in
4	ERPC		erpc-protection@gov.in
5	ERPC		hoo-erpc@gov.in
6	DVC	Central GENCO	sanjay.sharma@dvc.gov.in
7	DVC		santosh.panda@dvc.gov.in
8	NTPC		jaiprakashverma@ntpc.co.in
9	NTPC Farakka		sumeetnarang@ntpc.co.in
10	NTPC		sraybarman@ntpc.co.in
11	NTPC		ksureshbabu@ntpc.co.in
12	NTPC		arshadjilani@ntpc.co.in
13	NTPC Nabi Nagar		skupadhyay@ntpc.co.in
14	NTPC-Barh		aksrivastava16@ntpc.co.in
15	NTPC-Barh		abhishekmurari@ntpc.co.in
16	NTPC-TSTPS	suranjandas@ntpc.co.in	
17	BRBCL/NTPC	bnvadav01@ntpc.co.in	
18	PGCIL	Central TRANSCO	partha.ghosh@powergrid.in
19	POWERGRID ER-II		mithun.gayen@powergrid.in
20	POWERGRID ER-II		snayek@powergrid.in
21	POWERGRID ER-II		pmaity@powergrid.in
22	POWERGRID ER-I		sudeepkumar@powergrid.in
23	Powergrid, Odisha Project		eswar@powergrid.in
24	Powergrid, Odisha Project		ajayasahu@powergrid.in
25	WBSLDC	DISCOM	preetam72@gmail.com
26	ERLDC	ERLDC	surajitbanerjee@grid-india.in
27	ERLDC		dbiswas@grid-india.in
28	ERLDC		bilash.achari@grid-india.in
29	ERLDC		manasdass@grid-india.in
30	ERLDC	rkpradhan@grid-india.in	
31	GRIDCO	Others	ele.plsahoo@gridco.co.in
32	GRIDCO		ele.bpmohapatra@gridco.co.in
33	CHEMTROLS		anirudhya.saha@chemtrols.com
34	CHEMTROLS		anish.raigopal@chemtrols.com
35	CHEMTROLS		shivaji.dewanjee@chemtrols.com
36	CESC	Private GENCO	koushik.banerjee@rpsg.in
37	CESC		anupam.biswas@rpsg.in
38	CESC		debarshi.de@rpsg.in
39	MPL		rautpv@tatapower.com
40	GMR, Odisha		swapnait.panigrahi@gmrgroup.in
41	GMR, Odisha		diptikanta.panda@gmrgroup.in
42	JSW		biswanath.patel@jsw.in
43	JSW		mahendra.malik@jsw.in
44	APNRL		shiladityachatterjee@adhunikpower.co.in
45	APNRL		rajukumarsharma@gmail.com
46	APNRL		rahul.kumar@adhunikpower.co.in
47	MPL		jetir@tatapower.com
48	HEL		archita.dutta@rpsg.in
49	J IPL	jiplscheduling@jindalgroup.com	
50	INDIGRID	Pvt.TRANSCO	dinesh.laha@indigrid.com
51	WBSLDC		arnab.basu@wbsetcl.in
52	WBSLDC		utsab.aditya@gmail.com
53	WBSLDC		svkbanerjee@yahoo.com
54	WBSLDC		sanjibroy12235@gmail.com
55	WBSLDC		cecpwbsetcl@gmail.com
56	BSPTCL		sldc.bseb@gmail.com

Sl.No	Organization	Category	E-mail	
57	BSPTCL	SLDC/STU	gagankmishra@gmail.com	
58	SLDC, Ranchi, JUSNL		tuneshwarkumar@gmail.com	
59	SLDC, Ranchi, JUSNL		rimitopno@gmail.com	
60	SLDC, Ranchi, JUSNL		rajmailme82@gmail.com	
61	WBSETCL		sajalbag74@gmail.com	
62	WBSETCL		ce.wbsldc@gmail.com	
63	WBSETCL		cpd.wbsetcl@gmail.com	
64	OPTCL		ele.smsahoo@optcl.co.in	
65	OPTCL		ele.scdash@optcl.co.in	
66	SLDC, Odisha		ele.dpkar@sldcorissa.org.in	
67	SLDC, Odisha		sanjasldc@gmail.com	
68	WBPDC		State GENCO	mpodder@wbpdcl.co.in
69	WBPDC			rk.koley@wbpdcl.co.in
70	TVNL			bk20tvnl@gmail.com
71	OHPC	chandan.panda143@gmail.com		
72	OHPC	dasakshaya26@gmail.com		



Eastern Regional Power Committee

**MINUTES
OF
238th OCC MEETING**

Venue: ERPC Secretariat, Kolkata

Date: 17.04.2026

Contents

1. PART-A: CONFIRMATION OF MINUTES	3
1.1. Confirmation of Minutes of 237 th OCC Meeting held physically at ERPC Secretariat on 17 th March 2026	3
2. PART-B: ITEMS FOR DISCUSSION.....	4
2.1 Update on follow up agenda: ERPC	4
2.2 Issues for follow-up: ERLDC	14
2.3 High loading and N-1 violation of 400/220kV ICTs at Bolangir (POWERGRID): ERLDC	15
2.4 Sustained high frequency operation on 20 th , 21 st & 22 nd March 2026:ERLDC.....	16
2.5 Postponement of overhauling of GMR and JIPL thermal units: BSPHCL.....	21
2.6 Shutdown proposal of Thermal generating units: ERPC.....	22
2.7 Change in Default Day-Ahead Requisition in WBES to “Full Surrender”: ERLDC..	22
2.8 Frequency Response Performance (FRP) of Eastern Regional entities: ERLDC...	24
2.9 Non Receipt of DR & EL post tripping or AR from the end substation utilities: IndiGrid	26
2.10 Critical erosion by River Kamla Balan, at tower no 348 from both sides & line modification required at tower no 348 of 400 kV New Purnea-Muzaffarpur Line with provision of Pile foundation: Powerlinks.....	27
2.11 Review of Black Start Exercises of Hydro Stations of ER as per IEGC 2023 Compliance for the FY 2025-26 and associated Action Plan for Improvement :ERLDC	28
2.12 Data Collection for monitoring Pan-India Captive Generating Capacity: ERPC	30
2.13 Modification of SPS-1000 Scheme at Talcher for Facilitating lower power order in HVDC Talcher –Kolar: ERLDC	30
2.14 Restoration of Barh–Kahalgaon Ckt-1 & 2: NTPC	32
2.15 Construction power for Darlipali Stage-II: NTPC.....	32
2.16 Rescheduling of Unit-1 Overhauling:NTPC	33
2.17 Discrepancy in schedulling w.r.t Talcher Stage-1 :NTPC.....	33
2.18 Approval of Unit #1(Buxar Thermal Power Plant)Shutdown (12 +12 Days Total) for Performance Guarantee: SJVN	34
2.19 Shutdown request from BRBCL	34
2.20 Continuous S/D of 400kV D/C Binaguri-New Purnea TL (Ckt-1 & Ckt-2): POWERGRID	35
2.21 Certification of DVC's 400 kV STU Lines as Non-ISTS Lines Carrying ISTS Power: DVC	36
2.22 Declaration of high inflow season for Hydro-generating stations of Eastern Region for calculation of RTDA Accounts for FY 2026-27: ERPC	36
2.23 Issuance of Trial Run Certificate for 400 kV Farakka–Kahalgaon-I Line: ERLDC ..	37
3. PART-C: ITEMS FOR INFORMATION.....	38
3.1. ER Grid performance during March 2026	38
3.2. Non-Submission of FRC data in stipulated time-frame: ERLDC	38
3.3. Regarding Non-Submission of Forecasting Data from States: ERLDC.....	39
4. PART-D: OPERATIONAL PLANNING.....	41
4.1. Major Thermal Generating Units/Transmission Element outages/shutdown in ER Grid (as on 05-03-2026)	41

4.2.	Long outage report of transmission Element (MORE THAN 01 WEEK) (As on 05.04.2026):	
	43	
4.3.	Commissioning of new units and transmission elements in Eastern Grid in the month of March -2026	45
4.4.	UFR operation during the month of March 2026.....	48

EASTERN REGIONAL POWER COMMITTEE

MINUTES OF 238TH OCC MEETING HELD ON 17.04.2026 (FRIDAY) AT 10:30 HRS

Member Secretary, ERPC welcomed all OCC members and other participants who were present physically as well as those who had joined virtually to the 238th OCC Meeting.

Thereafter he requested all the participants to give brief introduction.

□ He outlined the performance of ER grid during **March-2026** highlighting the following points:

- In **March-2026**, energy consumption of ER was **16996 MU** which is **3 % more** than **March-2025**.
- In **March-2026**, Peak demand met of ER was **27876 MW** which is **1 % lower** than **March-2025**.
- ❖ Thermal **PLF** of **ER** during **January-2026** was **76%** whereas National average is **65%**.
- ❖ Generating stations whose PLF was more than **90%** during **March-2026**:

Utility	Generating station	PLF(%)
WBPDCCL	BAKRESWAR TPS	95
IPP	HALDIA TPP (HEL)	97

- ❖ During **March-2026**, **74.3 %** of the time, the ER grid frequency was within IEGC Band (49.90Hz-50.05Hz).

Coal stock position (As on 13.04.2026) is as follows:

SL.	Name of States/Power Stns.	% of Actual Stock vis-à-vis Normative Stock
1.	Jharkhand (TVNL)	308%
2.	Odisha (IB TPS)	86%
3.	West Bengal (WBPDCCL)	98%
4.	D.P.L. TPS	42%
5.	DVC	79%
6.	NTPC	90%

He also highlighted recent developments w.r.t some persistent issues as follows:

- A meeting was held on 9th April 2026 under chairmanship of Member(Power System), CEA regarding reconductoring of the Chukha transmission line wherein decision has been taken to re-tender the package through Powergrid.
- 7th ICT at Subhasgram(PG) has been accorded permanent status as per decision in the meeting under Member (Power Systems), CEA on 06th April, 2026.

GM, ERLDC touched upon the following key areas:

- All-India Peak Demand has already reached 239 GW and anticipated to reach 270 GW in this Summer.
- Eastern Region peak Demand is expected to touch 35GW in April 2026.
- Demand increase attributed is primarily to rising temperatures.
- West Bengal has reduced thermal generation during solar hours to accommodate renewable energy. Other ER states may also adopt similar practices for better renewable integration.

List of participants attached at **Annex-A**.

Member Secretary,ERPC requested S.E(Operation) to take up the agenda for discussion.

1. PART-A: CONFIRMATION OF MINUTES

1.1. Confirmation of Minutes of 237th OCC Meeting held physically at ERPC Secretariat on 17th March 2026

The Minutes of 237th Operation Coordination Sub-Committee meeting held on 17.03.2026 was circulated vide letter dated 25.03.2026.

Deliberations in the meeting

- ✦ *In line with observations received from ERLDC and subsequent deliberation, some alterations are hereby incorporated in the Minutes of 237th OCC Meeting as detailed hereunder:*

Agenda 2.1 a) Bus split operationalization at NTPC Kahalgaon:

"ERLDC informed that connectivity will be granted within a week after completion of Kahalagaon bus splitting."

This shall be rephrased as:

"ERLDC informed that FTC clearance will be granted within a week after completion of Kahalagaon bus splitting."

Agenda 2.1 j) Update on islanding schemes in ER. -- iii. Conduct of Mock Drills:

"ERLDC submitted that mock drill of islanding schemes is not possible due to anticipated load loss. As per IEGC Cl. 29(11), in case mock drill with field testing is not possible to be carried out for a particular scheme, simulation testing shall be carried out by the respective RLDC. Accordingly, simulation test results can be shared."

Agenda 2.14 Issues related to ERLDC outage portal: POWERGRID

"ERLDC submitted that the issue has already been discussed bilaterally. Based on the feedback, software developer team has already been intimated to incorporate essential features and functionalities."

Agenda 3.3. Reconductoring of 400KV Farakka-Kahalgaon D/C (Important for WB System): ERLDC

"ERLDC intimated that reconductoring work of 400kV FSTPP-KHSTPP Ckt-I has been completed and the line has been charged on 17.03.26 at 14:00Hrs. through tie bay.

OCC forum opined that reconductoring of 400KV Farakka-Kahalgaon ckt 2 may be facilitated post summer."

*Members confirmed the **Minutes of 237th OCC** with aforementioned modification.*

2. PART-B: ITEMS FOR DISCUSSION

2.1 Update on follow up agenda: ERPC

a) **Bus split operationalization at NTPC Kahalgaon**

As decided in **219th OCC** Meeting, a committee comprising of members from ERPC and ERLDC visited NTPC Kahalgaon on 17-10-2024 to assess the status of Bus splitting at 400kV level and way forward for operationalization of 400 KV Bus sectionalizer.

Following works need to be done to complete the installation of ICT 3 & 4:

1. Determination of underground cable conduit path for 400/132 kV ICT-3, 4 and 5 allocated for stage 2 supply.
2. Excavating the existing cable and relaying from Stage-1 132kV to New Stage-2 132kV switchyard, where ICT 3 & 4 will be connected.
3. Laying of additional 22.8 ckt. km control cable for STs.
4. Jumpering of ICTs in 132kV & 400kV level.
5. Bay equipment testing.

As per 55th TCC:

NTPC informed the forum that, as per the current progress of works, idle charging of ICT–3 and ICT–4 is expected to be completed by **December 2025**, and bus splitting at NTPC Kahalgaon is tentatively scheduled for completion by **April 2026**.

55th TCC Decision

TCC took serious note of the inordinate delay in implementation of the bus splitting operational scheme at NTPC Kahalgaon, which is critical for reduction of fault level at Kahalgaon.

TCC advised NTPC to:

- Share weekly progress reports with ERPC and ERLDC.
- Expedite the bus splitting works to ensure completion strictly as per the submitted timeline.

Deliberation in 237th OCC:

NTPC updated:

- ✓ Both ICTs were successfully charged on 11 March 2026.
- ✓ Charging of the new 132 kV switchyard is planned within the current month, and shifting of station transformers to the new switchyard is targeted by April 2026.

CTU Connectivity and Associated Works of Godda TPS(Adani):

- ✓ It was informed by Adani Power only 7.26 km of LILO line connectivity work is yet to be completed.
- ✓ ERLDC informed that connectivity will be granted within a week after completion of Kahalagaon bus splitting.

237th OCC decision:

- OCC advised NTPC to complete the bus splitting at Kahalgaon by 25th April 2026. Further, OCC opined that the request for ISTS connectivity of Godda TPS of Adani will be taken up after completion of Kahalgaon bus splitting and completion of LILO work by Adani.

Deliberations in the meeting

NTPC informed:

- *Work on bus splitting and related arrangements is progressing as planned.*

- the 400/132 kV ICTs are already charged. 132 kV new switchyard is also charged.
- Shifting of station transformers is the only pending work. Shifting of ST-3 & ST-4 is in progress while that of ST-5 is nearing completion
- As per present progress, the bus splitting at Kahalgaon shall be completed by 25th April 2026

OCC Decision

OCC advised NTPC to strictly adhere to the submitted timeline(25 April 2026) for completion of bus splitting at 400 kV Kahalgaon station.

b) Reconductoring of the lines of Chukha Transmission system under ERES-44 scheme

- Powergrid has been entrusted with the reconductoring work of various lines of Chukha Transmission system under ERES-44 scheme.
- The lines of Chukha Transmission System are more than 37 years old and are prone to outages. Further, reconductoring of some of the lines is critical for ensuring reliability of the supply in West Bengal system. Among the lines, reconductoring of 220 kV Malda-Gazole section(18 kM) is essential for operational flexibility of WB system and early completion of the reconductoring work on this section is critical for ensuring reliability of supply in Gazole and adjoining areas. It is worth mentioning that at present bus splitting is in operation at 220 kV Gazole S/s compromising the reliability of the supply.
- The inordinate delay in carrying out the reconductoring work of Chukha Transmission system would pose challenge to smooth & secure grid operation and reliable power supply to adjoining areas of West Bengal.

55th TCC Decision

- TCC critically noted the inordinate delay caused in carrying out the HTLS reconductoring of 220KV Malda–Gazole D/C which is very much essential to aid in operational flexibility WB.
- TCC also advised Powergrid to explore all the possibilities for diverting HTLS conductors from other projects on loan basis so that Reconductoring can be completed at the earliest and after LOA has been awarded the HTLS conductor may be returned to the concerned utility.
- TCC also opined that PowerGrid may take the help of WB for procurement of the required HTLS reconductor through a separate tender.

Deliberation in 55th ERPC meeting

Powergrid stated that LoA will be placed by Jan'26.

ERPC advised Powergrid to complete the reconductoring work before onset of coming summer.

As per 237th OCC Meeting

It was informed that the tender evaluation is still in progress and no firm date for placement of order was conveyed.

WB SLDC submitted the following:

- ✓ The tendering process has not been finalized even after significant delay (over two years).
- ✓ The delay is already causing operational difficulties, particularly in the 220 kV system, and may lead to increased congestion, higher outage risk, and supply challenges during the upcoming summer and election period.

- ✓ It was further noted that the network remains congested for a significant part of the year (~8 months), likely to worsen during peak summer, with project delays being a major contributing factor.

237th OCC Decision

OCC opined that the matter will be escalated by ERPC secretariat with Member (PS), CEA.

Latest status

A letter in this regard has been communicated from **ERPC Secretariat to Director(Projects), Powergrid** on 27.03.2026.

Deliberations in the meeting

Powergrid apprised:

- ✓ *Tender process faced objections from vendors related to qualification requirements (QR). Relaxations are being incorporated to allow broader participation under the “Make in India” initiative.*
- ✓ *Clarity in this regard has been obtained from CEA on 9th April 2026.*
- ✓ *Now, re-tendering shall be initiated with revised conditions to enable wider participation from prospective bidders.*

It was informed by MS,ERPC that the issue has been deliberated in the meeting under chairmanship of Member(Power System),CEA on 9th April 2026 wherein it has been decided that re-tendering of the packages under the subject scheme is to be taken up after incorporating suitable relaxation in prior operational experience in the tender documents to encourage wider participation of the bidders .

*Reply from Powergrid Corporate(dated 13.04.2026) in this regard is enclosed at **Annex-B.2.1(b)***

WB SLDC submitted:

- *Serious concern was raised regarding inordinate delay in reconductoring of the Malda–Gazole–Dalkhola transmission section.*
- *This delay has led to transmission constraint in Gazole(W.B) and adjoining areas. Severe congestion in North Bengal will result in reduction in power support from 160 MW to 130 MW. Consequently, minimum 30 MW of loadshedding has to be done in this Summer.*

OCC Decision

- ✓ *Powergrid was urged to submit a revised timeline for completion encompassing the entire schedule for re-tendering, award and execution i.r.o reconductoring of Chukha Transmission system. This shall be reviewed in every OCC for holistic monitoring of progress.*
- ✓ *This was referred to ensuing TCC meeting for deliberation.*

c) Intrastate Transmission Network Assessment & Mitigation – West Bengal

Modification of Existing SPS Scheme at Subhasgram (PG) with Undervoltage Logic

ERLDC Proposed modification of existing SPS at Subhasgram (PG) to include undervoltage logic with time delay to prevent voltage collapse. OCC advised SLDC, West Bengal, WBSEDCL and CESC to meet after puja to discuss the proposed modified SPS scheme at Subhasgram and share the outcome in next OCC.

237th OCC Meeting:

CESC informed:

- ✦ Wiring and installation works have been completed
- ✦ Final testing is currently in progress
- ✦ The scheme is expected to be commissioned within a week.
- ✦ Proper testing and validation, including circuit checks, shall be completed before commissioning
- ✦ SPS compliance certification shall be ensured prior to operation.

237th OCC decision:

It was advised that UVLS is to be implemented within a week with coordination of concerned stakeholders.

Update:

Logic was implemented by CESC at their end on 28.03.2026 and joint testing was also done on same day.

Deliberations in the meeting

OCC noted.

d) Intrastate Transmission Network Assessment & Mitigation – DVC:

Restoration of Koderma ICT & SPS at Bokaro

At Koderma TPS, ICT#1 has faced DGA violation and out of service for internal inspection. Shifting of one 315 MVA ICT from Durgapur to Koderma TPS is proposed as an interim measure for improving voltage at 132 kV level, especially in the upcoming Summer months.

As per 237th OCC:

DVC informed that:

- ✓ Koderma ICT-2 was charged on 07.03.2026.
- ✓ The SPS at Bokaro will be implemented by the end of March' 26.
- ✓ NIT has been notified for shifting of ICT from DSTPS and the order will be placed within two months.

237th OCC decision:

- OCC opined that the SPS at Bokaro and shifting of ICT from DSTPS to Koderma to be expedited at the earliest.

Update:

SPS at Bokaro was implemented on **19.03.2026**.

Deliberations in the meeting

ERLDC informed:

There are 2 stages in Bokaro SPS. In 1st Stage 220kV-Bokaro-Ramgarh-D/C will be tripped in case of over loading of Bokaro ICT (110% of rated capacity). If overloading still persists, then 132kV Bokaro-Barhi & 132kV Bokaro-Konar will be tripped in 2nd phase.

DVC submitted :

- *ICT-I at koderma is expected by May end. The tender for transportation of ICT from DSTPS has been fast tracked and expected to reach and commissioned as ICT-I at Koderma*
- *First phase of SPS at Bokaro by switching off 220kV Bokaro–Ramgarh line has been completed. As presently only one ICT is in service at Koderma, 2nd stage couldn't be implemented before commissioning of ICT-I.*

OCC Decision

DVC was advised to restore the ICT-I at Koderma positively by 31.05.2026 and subsequently expedite implementation of 2nd phase of SPS at Bokaro.

e) Intrastate Transmission Network Assessment & Mitigation-Odisha

Reference:

Implementation of the Under Voltage Load Shedding (UVLS) scheme in the Odisha system has been under review since the 231st, 232nd, 233rd, and 234th OCC Meetings held on 22.09.2025, 24.10.2025, 22.11.2025, and 23.12.2025 respectively.

The matter was also discussed in the recently concluded 55th TCC/ERPC meeting held on 16.12.2025 and 17.12.2025 at Kalimpong, West Bengal. As per deliberation in 55th TCC Meeting, **300MW load** has been identified and it will be operationalized before **Summer '26**.

The continued delay in implementation is posing increasing risks not only to the Odisha system but also to the Eastern Region as a whole during the forthcoming Summer-2026 period.

As per 237th OCC:

OPTCL informed that:

- ✓ The scheme is proposed to be implemented through the existing ADMS (Automatic Demand Management System) infrastructure at Odisha SLDC
- ✓ The ADMS infrastructure is already in place, and additional UVLS logic will be integrated
- ✓ Necessary logic development and configuration are under progress

Further, SLDC Odisha informed that the required logic can be configured and deployed by end of April 2026.

237th OCC Decision

OCC opined that the UVLS scheme is critical for handling peak summer demand and maintaining grid stability and it is to be expedited at the earliest with coordination of concerned stakeholders.

Update:

One meeting was conducted to discuss the implementation plan of the UVLS scheme, where ERLDC, OPTCL, and SLDC Odisha were present. It was discussed & finalized that the UVLS scheme would be implemented in two stages belong to the Mendhasal / Pandiabilli fed area, utilizing the existing ADMS infrastructure, while ensuring the required load relief under under-voltage conditions.

Deliberations in the meeting

SLDC Odisha updated that the order for implementing UVLS will be placed to the same vendor as for ADMS, on nomination basis. But placing order on nomination basis calls for recommendation from any authorised government entity.

OCC Decision

- *OCC opined that minutes of OCC meetings and previous ERPC meetings may be referred by OPTCL & SLDC Odisha for expediting the work and further implementation of UVLS scheme.*
- *OCC advised ERLDC to convene a special meeting involving all concerned stakeholders to expedite UVLS implementation in the intra-state network of Odisha.*

f) Restoration of 2nd ICT at Tenughat and upgrading 400 KV PVUNL- Tenughat line end termination at Tenughat:

Reference:

- ✓ Jharkhand is meeting a maximum demand of about 2,100 MW during Winter (December 2025 and January 2026). However, on several days, shortages in the range of 200-300 MW have been reported in Jharkhand despite commissioning of the Patratu 800 MW unit.
- ✓ These shortages are primarily attributed to frequent tripping of Tenughat units and thereby load restrictions in the Dumka/Gobindpur area due to inadequate transmission capacity. The constraints are mainly due to the availability of only a single ICT at Tenughat and loading restrictions on the 400 kV PVUNL–Tenughat line (earlier charged as 220KV Tenughat-Patratu) arising from non-availability of terminal equipment at Tenughat for power evacuation at 400 kV level. Additionally with Integration of 2nd Unit of PVUNL this loading will increase further and will aggravate the situation.

The following issues need to be addressed before Summer-2026:

Restoration of the second 400/220 kV, 315 MVA ICT at Tenughat.

Upgradation of the 400 kV PVUNL–Tenughat line-end terminations at the Tenughat end.

As per 237th OCC:

TVNL informed that the order has been placed by JUSNL for deployment of synchronized trolley for synchronize of the HV side and charging of HV side is scheduled to be completed by end of March' 26.

237th OCC Decision

OCC advised TVNL and JUSNL to restore the 2nd ICT at the earliest.

Deliberations in the meeting

TVNL informed that the 2nd ICT at Tenughat has been successfully synchronized on 20.03.2026.

OCC Decision

OCC noted.

g) Discrepancy i.r.o Reactive Energy billing at Subhasgram (PG)

During the month of December 2025, the Reactive Energy billing data indicates a reversal in the direction of MVAR flow between two groups of ICTs at Subhasgram (PG) Sub-station. One group comprising ICT-I and ICT-II shows positive MVAR flow, while the other group comprising ICT-III, ICT-IV, ICT-V, and ICT-VII shows negative MVAR flow. Since all ICTs are operated in parallel, such divergence in the direction of reactive power flow appears anomalous and technically inconsistent.

In **235th OCC** Meeting, WB SLDC briefed the observed discrepancy in energy billing data w.r.t Subhasgram (PG) and submitted:

- ✓ In two ICTs, MVAR charges are negative while in other four ICTs, the charges are positive.
- ✓ All transformers are operating in parallel, so this trend is unusual. This behaviour was not seen last year. Comparative data for the last few weeks shows a consistent anomaly.
- ✓ This discrepancy should be rectified to ensure accurate meter data and should be implemented in billing with retrospective effect.
- ✓ ERLDC apprised that the discrepancy is predominant in those ICTs where meters replaced from Genus make to Secure make.

237th OCC Decision

OCC advised POWERGRID to :

- Coordinate with Secure to obtain the final solution by 25th March 2026
- Ensure complete rectification (meter correction/replacement) within the committed timeline (~1 month)
- Further, it was agreed that:
 - ✓ The issue shall be resolved in the affected meters, ensuring uniform sign convention across all meters
 - ✓ After implementation of desired sign convention, reactive energy billing shall be corrected retrospectively, based on validated and standardized data.

Deliberations in the meeting

Powergrid submitted:

- ✓ *The import-export logic in four meters at Subhasgram (PG) corresponding to HV and LV side meter of ICT -6 along with 220 kV Subhashgram (WB) and 220 kV KLC Bantala (WB) feeders were modified on 08.04.2026. The details of the meters along with observations have been shared with ERLDC via email.*
- ✓ *Reactive energy validation challenges were highlighted due to lack of independent validation mechanism (unlike active energy) and billing is based on cumulative registers, not block-wise data*
- ✓ *It was further stated that, upon confirmation from ERLDC, the same logic will be implemented in all the SECURE make meters of ER.*

ERLDC apprised:

Reactive MVARH data for all seven ICTs and associated feeders at Subhashgram (PG) was presented for the period from 06.04.2026 to 12.04.2026 and the same is tabulated below:

	SUBHASGRAM- ICT-01 (HV SIDE)	SUBHASGRAM- ICT-02 (HV SIDE)	SUBHASGRAM- ICT-06 (HV SIDE)	SUBHASGRAM- ICT-03 (HV SIDE)	SUBHASGRAM- ICT-04 (HV SIDE)	SUBHASGRAM- ICT-05 (HV SIDE)	SUBHASGRAM- ICT-07 (HV SIDE)	220 kV Subhasgram (PG)- Subhasgram(WB)	220 kV Subhasgra m(PG)- KLC(WB)	SUBHASGRAM- ICT-06 (LV SIDE)
	ER-1534-A	ER-1483-A	NS-2973-A	NS-3000-A	NS-2930-A	NS-2935-A	NS-2919-A	NS-2942-A	NS-2921-A	NS-2996-A
DATE										
06-04-26	-176.1	-161	233.5	147.3	144.9	158.9	266.2	242.6	59.2	-347.8
07-04-26	-190.3	-172.6	278.9	159.3	158.2	149.8	293.5	389.4	82.6	-369.3
08-04-26	-183.5	-162.5	342448	150.5	147.1	163.6	264	9370.6	319059.2	-289484.5
09-04-26	-150.5	-144.7	-231.6	129.6	129.4	170.2	234.9	-406.7	-49	321.6
10-04-26	-155.3	-147.3	-216.4	135.9	135.5	92.7	241.8	-380.2	-43.5	289.9
11-04-26	-121.3	-115	-182.5	101.9	101.2	108.4	186.9	-244.8	-20.2	216
12-04-26	-36	0	-24.4	25.5	23.1	0	43.3	-119	-11.2	120

***All values are in MVARH. The highlighted sections represent the cases where the meter logic has been modified.**

Based on the Reactive register data, ERLDC informed the forum that, from 09.04.2026 onwards, the direction of reactive power flow on the HV side of ICT-6 is same as that of the Genus make meters installed at ICT-1 and ICT-

WBSEDCL stated that the discrepancy in logic is impacting the Reactive energy accounting, hence corrective action should be taken at the earliest. Moreover, there should be mechanism of validation of VAR data as it is posing significant commercial implications.

WB SLDC submitted :

Similar issue of reactive energy flow in reverse direction is being experienced in tie-lines of Binaguri-NJP ckt-I&II.

DVC informed that they will test and validate the reactive energy meters in their lab and inform OCC forum accordingly.

OCC Decision

- ✓ The forum noted the modification in logic done by PowerGrid in secure make meter at Subhashgram(PG). Further, forum advised PowerGrid to implement the same logic correction across all remaining SECURE make meters(176) of ER. Powergrid to share detailed information with ERLDC regarding Meter no, location, date & time whenever any change in meter logic is carried out.
- ✓ WB SLDC to share the list of tie lines where similar issue of reactive energy recording is encountered.
- ✓ OCC suggested for escalating the issue of reactive energy meter reading validation to NPC forum for standardization across all regions.

h) Update on islanding schemes in ER.

1.Patna Islanding Scheme under PSDF

- In 54th TCC meeting held on 23.06.2025, BSPTCL had proposed to implement Patna Islanding Scheme through Internal Resource Fund.
- However, a meeting was held on 24th June 2025 under the chairmanship of the Hon'ble Minister of Power and Housing & Urban Affairs, wherein the matter of Islanding Patna city was discussed. In the meeting, it was decided that the State of Bihar would submit a proposal for funding the Islanding scheme by the Ministry of Power).
- In compliance to minutes of the meeting held on dt. 24.06.2025, Board of Directors, BSPTCL has approved for implementation of Patna Islanding Scheme through PSDF in 131st BOD meeting held on dt. 17.07.2025 vide its resolution no. 131-06.
- In line with the above, a proposal has been submitted for Implementation of Patna Islanding Scheme under PSDF to NLDC vide this office letter no. 549 dt. 18.07.2025 along with all the required documents in compliance to minutes of meeting held on dt. 24.06.2025.
- Further, Chief Engineer (Generation), CEA has requested the recommendation of ERPC for implementation of Patna Islanding Scheme through PSDF.
- In 55th CCM meeting,
- The issue of Patna Islanding Scheme has been deliberated earlier in various forums. Though it was earlier decided by BSPTCL to implement Patna Islanding Scheme through Internal Resources but on subsequent development on the issue they have now approached the forum

for approval for PSDF funding for the same.

- Committee referred the above agenda to upcoming 55th TCC & ERPC meetings for their consideration and further decision on the issue.

55th TCC deliberation:

ERPC Secretariat informed that BSPTCL has requested for appraisal report of the islanding scheme in A5 format of PSDF and the same has already been sent to them for onward submission to PSDF.

As per 237th OCC:

SLDC Bihar informed that a proposal regarding 70% funding of the islanding scheme from PSDF has been approved by the board and the revised proposal will be forwarded to the PSDF committee.

Deliberations in the meeting

OCC Decision

OCC suggested for formation of a sub group committee under chairmanship of S.E. (Operation), ERPC comprising members from ERPC, ERLDC, concern SLDC and Generating company for regular monitoring of islanding scheme formation and implementation in the ER States. The committee shall coordinate with stakeholders and submit progress report in OCC.

2. IB Valley TPS(Budhipadar) Islanding Scheme

IB valley TPS Islanding scheme has also been put on hold for long time. The status regarding the same has been sought on urgent basis by Ministry of Power (Govt of India).

In 233rd OCC Meeting,

OPTCL updated that DPR i.r.o IB Valley TPS Islanding Scheme is not yet prepared and the proposed scheme is under review of Director, OPTCL.

- OCC took a serious note on slow progress in implementation of IB Valley TPS Islanding Scheme since this scheme has been pursued by ERPC since last five months.
- OCC advised OPTCL to highlight the importance of IB Valley TPS Islanding Scheme at the appropriate level and revert back within fortnight of December and the matter is referred to TCC for detailed deliberations.

Deliberation in 55th TCC meeting

Director(Op), OPTCL stated that they need a clarification regarding load quantum required for islanding operation and as per their assessment load of 140-160 MW can be arranged at Budhipadar end for islanding operation.

OPGC representative replied that minimum load of 150 MW is required for islanding operation with one unit of IB TPS.

55th TCC decision

- After deliberation, it was finalized that the scheme will be implemented with minimum load quantum of 140 MW at Budhipadar along with one unit of IB TPS generation.
- TCC pointed out the inordinate delay in implementing the scheme and opined that OPTCL & OPGC

shall take necessary steps to implement the scheme within six months.

As per 237th OCC:

OPTCL informed that the islanding proposal has been discussed with OPGC and OPGC is in the process of finalizing the work order and work order will be issued within a week.

Deliberations in the meeting

OPTCL updated:

Work order has been reportedly issued by OPGC to PRDC

ERLDC apprised:

- *Multiple revisions have been done in the scope of this islanding scheme. While earlier it was a two-unit configuration, in revised scheme one-unit configuration has been proposed with reduced load.*
- *Dynamic study of the original scheme had earlier been carried out by ERLDC.*

OCC Decision

- ✓ *OPGC was advised to clarify the role of vendor whom the work order has been placed, i.e whether it is for study or implementation of the scheme.*
- ✓ *ERLDC was advised to complete the revised study of IB Valley TPS islanding scheme with one-unit configuration.*
- ✓ *OCC sub-group formed in agenda B.2.(h).2 will coordinate with stakeholders and submit progress report in OCC.*

i) Status of upcoming thermal generation capacity addition in Eastern Region:

Deliberations in the meeting

Sr. No.	Plant Name/Agency	Unit No	Capacity (MW)	Status Update in 238th OCC
2	Patratu STPP (PVUNL)	2	800	Expected COD: 30.04.2026
3	Buxer TPP (SJVN)	2	660	Synchronization by end of April 2026.Expected COD: 31.05.2026

OCC Decision

In view of impending high demand season , it is imperative for the concerned thermal generating units to commence commercial operation as per scheduled timeline.

j) Review of AUFLS in Eastern Region: SCADA Integration & Data Updation

- ◆ *Based on the recommendation and decisions in 14th NPC meeting held on 05.02.24, 214th OCC meeting and special meeting on 10.07.2024, a load relief quantum of 6916MW was finalized for Eastern Region. UFR Feeders real time monitoring has been discussed in NPC as well as various fora of ERPC.*
- ◆ *Further, with new IEGC 2023 the same has been mandated as quoted below: IEGC 2023, Clause 13.d: "SLDC shall ensure that telemetered data of feeders (MW power flow in real time and circuit*

breaker status) on which UFR and df/dt relays are installed is available at its control centre. SLDC shall monitor the combined load in MW of these feeders at all times.

- ◆ SLDC shall share the above data with the respective RLDC in real time and submit a monthly exception report to the respective RPC. RLDC shall inform SLDCs as well as the concerned RPC on a quarterly basis, durations during the quarter when the combined load in MW of these feeders was below the level considered while designing the UFR scheme by the RPC. SLDC shall take corrective measures within a reasonable period and inform the respective RLDC and RPC, failing which suitable action may be initiated by the respective RPC.”

Deliberations in 237th OCC meeting

- AUFLS implementation (as per 14th NPC) was reviewed. SLDC Ranchi reported Stage-I & II completed, Stage-III largely completed, and Stage-IV in progress. Further, SLDC Bihar highlighted ongoing feeder mapping, will be completed by April 2026.
- MS ERPC emphasised on accurate feeder mapping, proper AUFLS configuration, and regular status updates to ERPC.

237th OCC decision

Bihar, Jharkhand and Sikkim shall prioritize feeder mapping and expedite pending AUFLS stages. Complete implementation (including mapping) by **April 2026**, with regular progress reporting to ERPC.

Deliberations in the meeting

Both Bihar & Jharkhand updated to Complete AUFLS implementation as well as SCADA integration by end of May 2026.

OCC Decision

*OCC noted the latest status enclosed at **Annex B.2.1.(j)***

2.2 Issues for follow-up: ERLDC

SPS for ACCP-II/JSPL

Following the 233rd OCC meeting, a special meeting was held on November 26, 2025, to discuss the implementation of System Protection Schemes (SPS) for the new ACCP-II plant, during which OPTCL was advised to assess existing protection adequacy at the JSPL site.

Although the site visit was eventually conducted on January 11, 2026, the overall implementation remains significantly delayed. While JSPL has implemented one SPS for injection control, a second scheme designed to restrict drawal at the Meramandali end is currently pending the transmission of Talcher-Meramandali power flow data from OPTCL. Consequently, OPTCL has apprised that installing the necessary RTU at Meramandali for data visibility will require approximately two months.

Deliberations in the meeting

OPTCL updated:

JSPL has placed purchase order for procurement of RTU required for data telemetry of 400kV Talcher-Meramundali lines to JSPL for SPS action. The delivery of the RTU is expected in two weeks. Thereafter SPS for drawl restriction would be configured at JSPL end.

OCC Decision

OCC advised OPTCL to coordinate with JSPL so that the proposed SPS gets implemented on time.

2.3 High loading and N-1 violation of 400/220kV ICTs at Bolangir (POWERGRID): ERLDC

Bolangir S/S is one of the major 400/200kV S/S in western Odisha catering load to Bolangir, Kesinga, Bargarh & Katapalli areas. In recent part, demand in this part of Odisha has increased significantly, which ultimately impacts the loading of ICTs of Bolangir. Supporting source of these areas is 220kV-Lapanga-Katapalli -D/C, which also operating at high loading mainly during summer period. ICT loading further increases with opening of 220 kV Katapalli-Bolangir(PG) and 220kV Katapalli-Bargarh lines to limit the loading of 220 kV Budhipadar-Lapanga D/c and 220 kV Lapanga-Katapalli D/c which are not N-1 compliant.

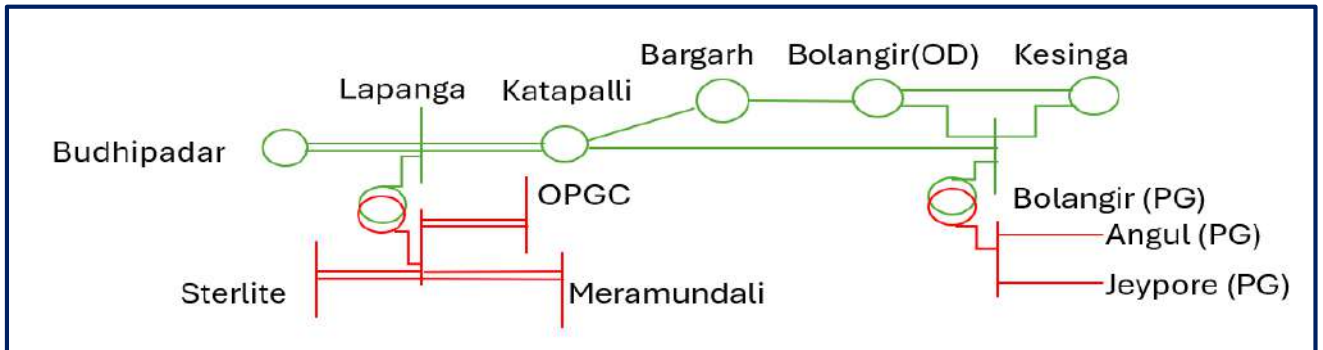

The matter was raised in 38th CMETS-ER meeting held on 27th December 2024 where in N-1 violation of ICT loading at Bolangir was deliberated. It was suggested that, in view of increasing trend of load in ICTs and future load growth, additional ICT may be installed at Bolangir as considerable time is required for approval, procurement and installation of ICT. In the meeting OPTCL stated that the present loading of Bolangir ICT is due to split operation of Lapanga – Katapalli – Bargarh – Bolangir 220kV corridor at Katapalli. They are in process of reconductoring of Lapanga – Katapalli 220kV section, after which the entire section would be operated in connected mode, thereby relieving the loading of Bolangir ICTs. It was decided to review the requirement of ICT augmentation in future as per system requirement / operational feedback.

The loading of ICTs at Bolangir are on higher side as observed in 2026 and violating N-1 loading limit of 360MW due to opening 220kV links from Katapalli as evident from the loading pattern presented below.

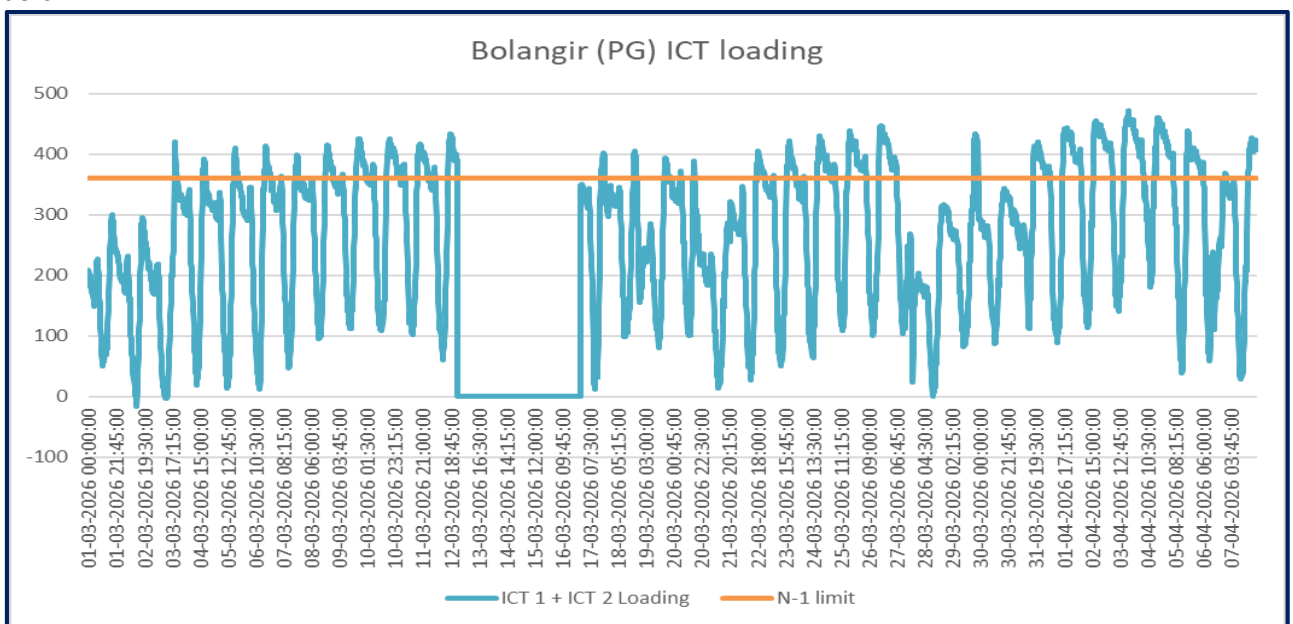

Deliberations in the meeting

ERLDC intimated:

- *Bolangir (PG) is a critical node for power supply in Western Odisha, catering to areas including Bargarh, Katapalli, Sadheipalli and Kesinga with solar generation connected downstream at Kesinga.*
- *During non-solar period, the loading on the 220 kV Katapalli–Lapanga D/C line becomes significantly high. To manage this loading, the 220 kV Katapalli–Bolangir (PG) line and either the 220 kV Katapalli–Bargarh or 220 kV Bargarh–Sadheipalli intra-state lines are kept open. However, this operational arrangement results in increased loading on the ICTs at Bolangir, leading to violation of the N-1 security criteria.*

OPTCL updated:

- *Reconductoring of the 220 kV Katapalli–Lapanga D/C line along with closure of the 220 kV interconnection with Bolangir (PG) was planned earlier.*
- *But, the earlier tender could not be finalized and a fresh tender has since been floated on 13.04.2026.*

OCC Decision

OCC advised OPTCL to expedite the reconductoring work of the 220 kV Bolangir–Katapalli line. It was also recommended that the issue may be taken up in forthcoming TCC/ERPC meeting .

2.4 Sustained high frequency operation on 20th, 21st & 22nd March 2026:ERLDC

- *Sustained high-frequency operation experienced on 20th, 21st and 22nd March 2026, particularly during solar hours, mainly due to inclement weather in major load centres coupled with high solar power generation in the Norther, & Western parts of India.*
- *The maximum frequency touched 50.50 Hz on 21st March 26 at 13:01hrs. Frequency remaining above 50.05 Hz for around 30%, 25%, and 21% of the time on those days respectively. NLDC dispatched significant TRAS-down reserves under the Emergency Category, reaching 20–23 GW on all three days, with the majority of curtailment sourced from Renewable Energy (RE), but still the frequency had remained above the band.*
- *The key highlights with regard to high frequency of the grid are as under:*

Date	Within Band (%)	Above Band (%)	Max Frequency (Hz)	Time
20 Mar	63.47	30.44	50.37	13:19
21 Mar	70.47	24.41	50.50	13:01
22 Mar	74.81	21.06	50.30	18:01

- *Major Contributing factors for high-frequency operation in the Indian power system on 20th, 21st and 22nd March 2026 are listed below:*

a) Suppressed demand due to widespread rains and weekend.

- b) Over-injection by VRE sources.
- c) Limited flexibility from hydropower stations and pumped storage plants.
- d) Inability of intra state generators to backdown up to 55% of MCR.
- e) Lack of DOWN reserves at the inter-state level.

In ER, we have analysed the data for 20.03.2026 (as on that day frequency remained max duration over the band) as a sample study in respect of drawl by Sates, Injection ISGS thermal power plants, IPPs and States Thermal. The overall issue of high frequency during the stated days can be broadly summarised due to (a) Under drawl by States during the high frequency duration (b) Inability of intra state generators to backdown up to 55% of MCR. (c) Over-injection by ISGS/IPPs.

A) State Deviation Analysis:

In ER, under drawl was observed in WB, Bihar, Jharkhand and DVC during the high frequency period (11:45 hrs to 14:20 hrs on 20.03.2026). Although, requisition of States from ISGS generators are at or below their MTDL levels, under-drawal conditions persisted, contributing to frequency rise.

Underdrawl of ER States on 20.03.2026 based on 1 min SCADA Data:



A) Inability of intra-state generators to backdown up to 55% of MCR:

It was observed from the analysis that there was available headroom for further backing down of state thermal generation up to 55% of MCR, but this flexibility was not fully utilized across region. List of state generators where margin was available for further backing down:

Sl. No.	Thermal Plants	State	Minimum Actual Generation (%of DC)	
			21.03.2026	22.03.2026

1	Tenughat TPS	Jharkhand	81%	66%
2	Mejia TPS	DVC	66%	71%
3	Raghunathpur	DVC	71%	71%
4	IB TPS Stg-1	Odisha	66%	61%
5	OPGC_STU	Odisha	85%	70%
6	Bandel TPS	West Bengal	83%	75%
7	Kolaghat TPS		76%	63%
8	Bakreswar TPS		74%	62%
9	DPL TPS		76%	76%
10	HALDIA TPS	West Bengal	85%	67%
11	HIRANMAYEE TPS	West Bengal	73%	73%

This persistence issues of intra-state generators MTDL were discussed in various forum including ER OCC/TCC meetings. Similar high-frequency operation on 4th, 11th, and 25th August 2024 for which Grid-India, vide its letter dated 17.09.2024, submitted a Report to the Commission on high-frequency operation on 4th, 11th, and 25th August 2024.

B) Over-injection by ISGS/IPPs in ER on 20.03.2026:

In the Eastern Region, JITPL (JIPL) was scheduled down to 55% MCR (625 MW) under TRAS emergency down, however, significant over-injection was observed, indicating a failure to adhere to schedules despite repeated instructions. Furthermore, it has been observed that JIPL was over injecting during high frequency period on an almost daily basis despite 55% MTDL schedule. A formal letter from ERLDC has been sent to JITPL dated 30.03.2026 requesting for providing reason for non-adherence to the schedule. On 21.03.2026, during high frequency operation, it has been also seen that NTPC Talcher also over-injecting despite our repeated pursuance from Control Room.

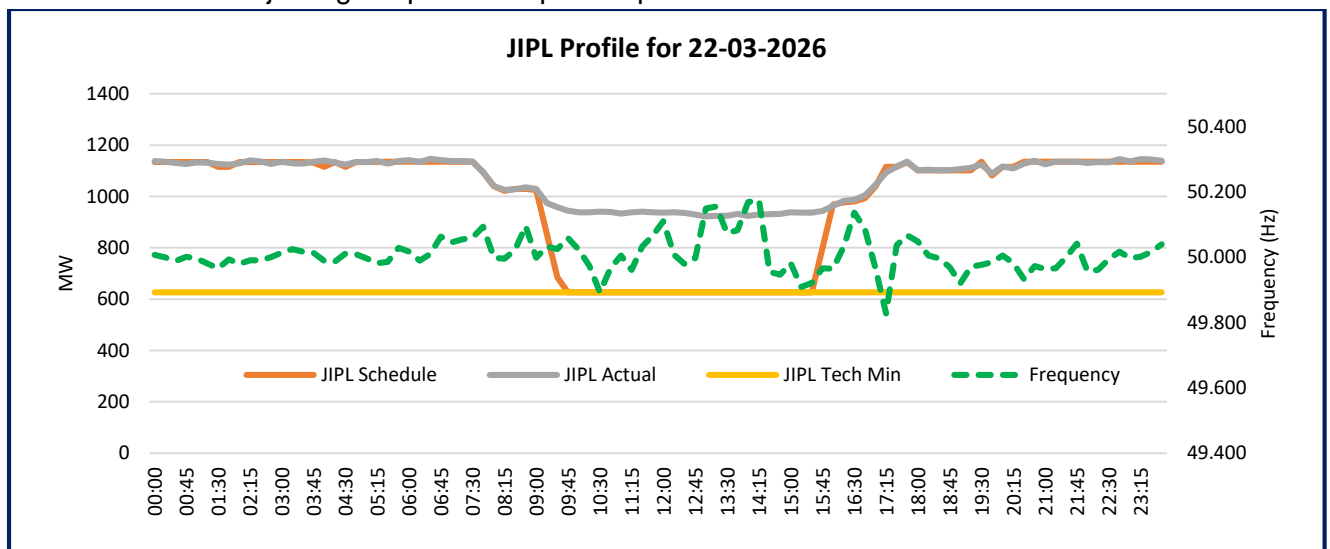

In-firm Generation: On 20.03.2026 during high frequency period, PVUNL unit #2 (As Infirm) continuously injected in tune of 250-350 MW despite our follow up which aggravate the frequency excursions.

Past References, Deliberations & Resolutions

High-frequency operation events have been discussed in several regional and national forums to implement corrective measures and contain grid frequency within the IEGC band.

1. **214th OCC Meeting of ER dated 23.04.2024:** All thermal GENCOs were advised to share the updated status of their respective units regarding their capability to achieve the 55% Minimum Technical Limit (MTL) and 40% MTL as per CEA flexible operation of coal fired thermal generating units.
2. **226th OCC Meeting of ER dated 22.04.2025:** High-frequency operations during April 2025 were discussed, leading to the following decisions:
 - All intra-state generators, including WBPDC, were advised to file petitions before their respective SERCs to address financial concerns regarding part-load compensation.
 - Intra-state generators were encouraged to participate in the TRAS market which would improve down-reserves while providing incentives for generators.
 - State generators were advised to seek approval from regulatory bodies for participation in the TRAS market.
3. **CERC Workshop (Dated 01.08.2025, Kolkata):** In the discussions held during the Workshop on addressing various challenges faced by the states in Operational Planning for safe, secure, and reliable integrated operation of the power system," chaired by the hon'ble CERC Chairperson, it was suggested that SERCs should incorporate suitable provisions for part-load compensation in State Regulations.

The requirement to operate intra-state generators at a 55% Technical Minimum and the corresponding need for part-load compensation mechanisms have been deliberated extensively. **However, the necessary enabling provisions are yet to be incorporated by several SERCs, and many state generators have not yet achieved consistent 55% MTDL operation.** Given the rapid increase in RE capacity, high-frequency excursions during peak RE generation periods are likely to intensify unless reserve margins are made available.

In view of the above, update may be provided for the followings:

- a) Status of enabling regulatory provision for part-load compensation of Intra-State generators.
- b) Update of implementing necessary measures to achieve the 55% Minimum Technical Limit (MTL) or 40% MTL as per CEA's report on flexible operation of coal fired thermal generating units.
- c) Update of State generators regarding approval from regulatory bodies for participation in the TRAS market.
- d) Review of action which can be taken by States/ISGS/IPPs for avoiding recurrence of under draw/over injection as happened on 20th, 21st & 22nd March 2026.

Deliberations in the meeting

ERLDC apprised:

- *Sustained high-frequency events were observed in ER grid on 20th, 21st, and 22nd March 2026. Frequency reached up to 50.37 Hz on 20th March. This may partly be attributed to High solar generation along with Low system demand in the weekend.*
- *An analysis of the portfolio management of ER States was presented covering drawl by States, injection from ISGS thermal stations, IPPs, and State thermal generation during the high-frequency conditions observed on 20th, 21st, and 22nd March 2026.*
- *From the presentation, it was observed that during the high-frequency period (11:45 hrs to 14:20 hrs on 20.03.2026), under drawl conditions prevailed in West Bengal, Bihar, Jharkhand, and DVC.*

This occurred despite State requisitions from ISGS stations being at or below their Minimum Turndown Levels (MTDL), thereby contributing to high frequency.

- *Concern was also raised regarding over-injection by JIPL against its MTDL schedule, particularly when all-India RE curtailment was in the range of ~20 GW during solar hours across the three days. All these factors aggravated the high-frequency conditions.*
- *It was highlighted that adequate margin was available for further backing down of State thermal generation up to 55% of MCR. However, this flexibility was not fully utilized, which could have helped reduce persistent under drawl conditions and mitigate frequency rise.*

Regarding Inability of Intra-State Generators to Back Down up to 55% of MCR:

- *DVC submitted:*
 - *RTPS Unit #2 was operating under bearing vibration constraints, limiting its ability to reduce load beyond a certain level.*
 - *At Chandrapura TPS, generation had to be maintained at higher levels due to prevailing transmission constraints at Bokaro and Koderma ICTs (single ICT at Koderma), restricting backing down even during high-frequency conditions.*
- *WBPDCCL confirmed that its thermal units are technically capable of operating at 55% of MCR. However, due to the absence of a part-load compensation mechanism, units were generally operated above MTDL.*
- *SLDC Odisha informed that units are generally operated down to MTDL and agreed to review the reasons for higher generation during the specific high-frequency periods.*

Regarding 40% Minimum Technical Load (MTL) & status of units under pilot phase. (PHASE-I)Duration: July 2024 to June 2026).

As per CEA’s report on flexible operation of coal fired thermal generating units- phasing plan, following units in ER have been given target to meet 40% of MCR.

<i>Phase</i>	<i>Sector</i>	<i>Organization</i>	<i>Name of the Project</i>	<i>Unit No</i>	<i>Capacity (MW)</i>	<i>Region</i>	<i>Target date</i>
<i>I</i>	<i>Central</i>	<i>DVC</i>	<i>BOKARO TPS `A` EXP</i>	<i>1</i>	<i>500</i>	<i>ER</i>	<i>Nov 2024</i>
<i>I</i>	<i>Central</i>	<i>DVC</i>	<i>RAGHUNATHPU R TPP</i>	<i>2</i>	<i>600</i>	<i>ER</i>	<i>Jan 2025</i>

ERLDC emphasized that with the addition of renewable energy capacity under the Government’s 500 GW target, high-frequency events are expected to increase. Accordingly, higher down-regulation margins will be essential. Achieving operation at 40% of MCR is therefore critical, and all stakeholders must take necessary steps to meet this requirement.

DVC highlighted that sustained operation at 40% load, along with frequent load variations during solar hours, may lead to increased wear and tear, higher tube leakages and outages. Availability of higher GCV coal may mitigate such issues. However, consistent supply remains a challenge. Similar concerns were echoed by NTPC.

Regarding Part-Load Compensation for Intra-State Generators:

It was apprised that the issue of part-load compensation enabling Intra state generator's operation up to 55% MTL has been discussed in 214th OCC Meeting dated 23.04.2024, 226th OCC Meeting dated 22.04.2025 & CERC Workshop held on 01.08.2025 at Kolkata.

- WBSEDCL informed that the matter is under consideration at the State Commission and regulation in this matter is expected after the State Assembly elections.
- SLDC Odisha assured that the issue would be taken up with the Odisha Electricity Regulatory Commission.

OCC Decision

- ✓ All ER states need to submit Action Taken reports (ATR) to ERPC/ERLDC for high-frequency events on 20th, 21st, and 22nd March 2026 by 30.04.2026.
- ✓ All SLDCs/Gencos shall adhere to schedules during high-frequency conditions and comply with ERLDC directions.
- ✓ All SLDCs/DISCOMs shall pursue respective SERCs for implementation of part-load compensation mechanisms to enable additional flexibility in State thermal generation.
- ✓ Feasibility of achieving 40% technical minimum needs to be explored gradually with technical validation. Units identified under the phasing plan shall adhere to timelines for achieving operation at 40% of MCR. The GENCOs will submit the constraints faced by thermal generating units for achieving 40% MTL to ERPC within 2 weeks.

2.5 Postponement of overhauling of GMR and JIPL thermal units: BSPHCL

With reference to the subject cited above and letters under reference, I would like to draw your kind attention to the fact that the proposed shutdown of JIPL U#2 (30.07.2026 to 29.08.2026), GMRU#2 (21.06.2026 to 12.07.2026) and GMRU#1 (19.07.2026 to 09.08.2026) for planned overhauling coincides with Bihar's peak demand period (April 2026 to Sept 2026). The details of the shutdown proposals along with the requested revised period are tabulated below.

Sl. No.	Plant/Unit Name	Capacity (MW)	Shutdown Proposal Period from Generators	Requested by BSPHCL for revised period
1	JIPL U#2	660	30.07.2026 to 29.08.2026	During Oct'2026 to Mar'2027
2	GMR U#2	350	21.06.2026 to 12.07.2026	
3	GMR U#1	350	19.07.2026 to 09.08.2026	

According to the demand Projection of BSPHCL for April 2026 to September 2026, It has been observed that Bihar is likely to face a significant power deficit situation particularly during peak and night hours Under such circumstances, the proposed shutdown of the said unit of JIPL and GMR is likely to further aggravate the power deficit situation as Bihar has a significant share from these units i.e. 260 MW (GMR) and 228 MW (JIPL), which could not be effectively mitigated by procuring power through open market (DAM & RTM) as volume clearance often extremely low during peak and night

hours. Resulting, the State may be compelled to impose load restriction in order to maintain grid discipline.

Therefore, in view of the above scenario, the matter regarding postponement of aforesaid shutdown during the lean demand period of Bihar i.e. from October 2026 to March 2027 may please be considered so that adequate power availability in peak hours can be ensured.

Deliberations in the meeting

- GMR expressed concern on operational constraints of units in Kamalanga TPS owing to ID fan limitations Bag filter damage.
- JIPL requested for shutdown of Unit#2 from 30th July 2026 for boiler license renewal.

OCC Decision

- ✓ OCC opined that in line with MOP guidelines, no shutdown of thermal generating unit can be allowed during peak demand period (till July 2026).
- ✓ Shutdown requests for GMR units (1&2) will be reviewed in June 2026 and may be considered based on power supply position of ER as well as concerned beneficiary.

2.6 Shutdown proposal of Thermal generating units: ERPC

Shutdown request of Kamalanga TPS: GMR

- U#2 of GMR Kamalanga Energy Limited is facing operational issues due to high bag filter DP for which the bags are to be replaced. Also, the boiler license is expiring in July 2026.
- Hence, as a necessity towards maintaining safety and reliability, on the availability of resources at the earliest, it is planned to take AOH of **Unit # 2** from **21st June 2026** for a duration of **22 days**.
- Also it is planned to take AOH of **U#1** from **19th July 2026** for a duration of **22 days**, as its **boiler license** is expiring in **July 2026**.

Shutdown Program of North Karanpura STPP: NTPC

- ✓ It is informed that, NKSTPP Unit #2 was taken under forced outage on 24.03.2026 due to the observation of abnormal sound from the front pedestal, accompanied by already high HPT shaft and pedestal vibrations.
- ✓ A detailed internal inspection of the HPT, IPT, and LPT is currently in progress. Unit restoration is tentatively expected by 01.05.2026

Deliberations in the meeting

NTPC delivered presentation highlighting causes of the unit #2 being under forced outage. (Annex B.2.6) Abnormally high vibrations were experienced in the turbine shaft prior forced shutdown.

OCC Decision

- ✓ NTPC was advised on restoration of the unit#2 of NKSTPP as per submitted timeline.
- ✓ Shutdown requests for GMR Unit# 2 will be reviewed in June 2026 and may be considered based on power supply position of ER as well as concerned beneficiary.

2.7 Change in Default Day-Ahead Requisition in WBES to “Full Surrender”: ERLDC.

- ISGS (Section 62 generating stations whose scheduling is done as per beneficiaries' share) presently declare their Declared Capacity by 06:00 hrs on D-1 for the D Day. Based on the declared capacity submitted by ISGS, entitlements for each beneficiary/State are computed as per their

respective share allocation by 07:00 hrs. Thereafter, beneficiaries/States submit their requisitions in WBES against their entitlements up to 08:30 hrs on D-1.

- WBES provides multiple options to beneficiaries/States for submitting requisitions, as listed below:
 - Total Full Requisition
 - Full Surrender
 - On Bar Full Requisition
 - Manual Input
- These options enable beneficiaries to submit their requests as per their operational requirements. At present, the default option in WBES is “Total Full Requisition.” Accordingly, in cases where a beneficiary does not submit any requisition for a generating station, the system considers it as full requisition and prepares the schedule accordingly. Such default treatment may lead to unintended over-scheduling and may not reflect the actual requirement of beneficiaries and may result in violation of GNA limit by States.
- In order to address the above issues, it has been proposed to change the default option in WBES from “Total Full Requisition” to “Full Surrender.” Under this proposed arrangement, if a beneficiary/State does not submit any requisition for a particular ISGS by 08:30 hrs on D-1, it shall be treated as zero requisition for that station and the schedule shall be prepared accordingly. However, beneficiaries shall continue to have the flexibility to select any of the available options, i.e., Total Full Requisition, On Bar Full Requisition, or Manual Input, and submit their block-wise requisitions within their GNA limits.
- Further, system-generated email notifications shall be issued prior to the closure of the requisition submission window (08:30 hrs on D-1).
- The above change shall be implemented on 21.04.2026 (D-1) for scheduling w.e.f. 00:00 hrs of 22.04.2026 onwards. Accordingly, from the said date, the default option for requisition submission in WBES shall be “Full Surrender.” All ER beneficiaries are requested to align their scheduling practices with this new default option of WBES.

The above is submitted for information and further deliberation of OCC.

Deliberations in the meeting

ERLDC submitted:

- ✓ *Default day-ahead requisition, which was earlier considered as Full requisition shall be henceforth changed to Zero (Nil) requisition in WBES.*
- ✓ *The changes shall be incorporated in the WBES portal w.e.f 22nd April (00:00 hrs).Changes are being implemented at all-India level as per decision of NLDC.*
- ✓ *As per new norms, beneficiaries have to actively submit requisition by 08:00 hrs and failure to do so will result in zero schedule*
- ✓ *The rationale behind this change is to avoid pro-rata curtailment due to GNA limits,enable merit-order-based scheduling by beneficiaries and improve cost optimization.The present practice of pro-rata curtailment in schedule is not done in merit order.*
- ✓ *To explain the rationale further, relevant clauses from IEGC were alluded to as follows:*
 - ☐ *As per Clause 49(1)(f)(i) of the IEGC 2023, “requisitions are to be furnished by the concerned SLDC on behalf of intra-State drawee GNA grantees after publication of entitlement and within the stipulated timeline”. Accordingly, submission of requisition remains an active responsibility of the concerned SLDC, even when the beneficiary intends to avail full entitlement.*

- As per Clause 45(14) clause of the IEGC 2023, “schedules under GNA are required to remain within the granted GNA limits. Under the existing default option of “Total Full Requisition”, instances of requisitions exceeding GNA limits have been observed. Consequently, after closure of the requisition submission timeline [08:30 hrs of (D-1)], RLDC undertakes pro-rata curtailment to ensure compliance with GNA limits, which may result in deviation from Merit Order Despatch (MoD) principles. Alternatively, with default option as “Full Surrender”, the beneficiaries shall provide block-wise requisition following MoD and the WBES shall allow such requisition up to the GNA limit of the beneficiary”.
- ✓ I.r.o keeping the default requisition as zero, it was clarified that as per IEGC 2023 during DA requisition at 08:00 hrs, beneficiaries are allowed to provide any requisition from 0 to entitlement quantum and thus, MTDL share requisition cannot be mandated during DA requisition.
- ✓ A workshop is scheduled on 17.04.2026 for making ER constituents aware of the modalities of newly introduced changes in scheduling. The need of changing the default DA requisition option will be explained along with available options in WBES for requisition submission for facilitating a smooth transition.

Record of notes of the session organized by ERLDC on 17.04.2026 is attached as **Annexure-B.2.7**

WBSEDCL submitted:

- ✓ West Bengal is regularly submitting requisition in WBES as per timelines.
- ✓ The decision of changing default day ahead requisition in WBES has been taken without prior consultation among stakeholders. Feedback should have been taken from all beneficiaries prior to introducing these changes.
- ✓ Concerns were raised on missed requisitions due to system failure or operational disruptions.
- ✓ To keep default requisition upto 55%(MTDL) instead of zero was suggested.

OCC Decision

- OCC opined that relevant feedback should be sought from all stakeholders prior to implementing such major changes in scheduling software. ERLDC was advised to address concerns of all stakeholders in the workshop for awareness of the changes to be implemented in WBES.

2.8 Frequency Response Performance (FRP) of Eastern Regional entities: ERLDC

IEGC Reg. 30(10) (q) mandates that “NLDC, RLDCs and SLDCs shall grade the median Frequency Response Performance annually, considering at least 10 reportable events. In case the median Frequency Response Performance is less than 0.75 as calculated as per Annexure2, NLDC, RLDCs, SLDCs, as the case may be, after analysing the FRP shall direct the concerned entities to take corrective action. All such cases shall be reported to the concerned RPC for its review.”

“Each control area shall be graded based on median Frequency Response Performance annually (at least 10 events) as per following criteria:

TABLE C: FREQUENCY RESPONSE CRITERIA

Performance	Grading
FRP ≥ 1	Excellent

$0.85 \leq FRP < 1$	Good
$0.75 \leq FRP < 0.85$	Average
$0.5 \leq FRP < 0.75$	Below Average
$FRP < 0.5$	Poor

ERLDC has computed and graded median FRP of each control area (States and Inter State Generating Stations and IPPs) under its jurisdiction for FY 2025-26 (All 18 events), in compliance with IEGC Reg. 30(10) (q) and the same has been intimated to the concerned entities vide mail dated 07.04.2026. Further, a letter from ERLDC dated 10.04.26 has been issued to the generating plants whose median frequency response is less than 0.75 for taking corrective action.

The performance of generators is given below:

Generating Plant	Median FRP	FRP Performance
FSTPP I&II	4.42	Excellent
FSTPP III	3.18	Excellent
KhSTPP I	0.11	Poor
KhSTPP II	4.61	Excellent
TSTPS-I	1.99	Excellent
BARH-1	0.48	Poor
BARH-2	0.97	Good
GMR	3.52	Excellent
MPL	1.40	Excellent
Adhunik	2.86	Excellent
JIPL	0.66	Below Average
BRBCL	4.06	Excellent
DIKCHU	2.25	Excellent
NPGC	2.53	Excellent
DARLIPALLI	2.09	Excellent
NORTH KARANPURA	3.12	Excellent
JSWEUL	0.63	Below Average
PVUNL	1.18	Excellent

All the Generators as tabulated above may review the performances and those where Median FRP is **less than 0.75** may share corrective action plans within **30th April,2026**.

The performance of states is given below:

States	Median FRP	FRP Performance
Bihar	0.10	Poor
Jharkhand	0.54	Below Average
DVC	1.15	Excellent
OPTCL	-0.74	Poor
WB	0.59	Below Average

Deliberations in the meeting

ERLDC presented the analysis of Frequency Response Performance (FRP) of generating stations and states in the Eastern Region for FY 2025–26, in compliance with IEGC Regulation 30(10)(q).

The importance of Primary Frequency Response in maintaining grid stability was emphasized and all entities with median FRP less than 0.75 were requested to analyze their performance, identify gaps, and submit corrective action plans at the earliest.

It was further highlighted that SLDCs need to carry out FRP calculations for generating units under their respective jurisdiction and share the same with ERLDC and ERPC.

OCC Decision

- *OCC advised all SLDCs to carry out FRP calculations for generators within their jurisdiction in accordance with IEGC provisions and share the results with ERLDC and ERPC.*
- *OCC advised all generators to review their FRP performance and, wherever FRP is below the IEGC-prescribed limit (0.75), analyze the reasons, take necessary corrective measures to improve frequency response, and submit the corrective action plan to ERLDC and ERPC.*

2.9 Non Receipt of DR & EL post tripping or AR from the end substation utilities: IndiGrid

- IndiGrid Limited, through its Special Purpose Vehicles ENICL, OGPTL, and PKTCL owns and operates transmission line assets within the region. It is pertinent to highlight that IndiGrid's scope is limited to the line portion, and the end substations fall outside its jurisdiction, being owned and operated by respective utilities.
- In this context, it has been consistently observed that in the event of line tripping or operation of AR, DR and EL from the corresponding end substations are not received in a timely manner. The availability of DR and EL is critical for accurate identification of fault type, root cause analysis, and for meeting internal compliance and regulatory requirements. Furthermore, such data is indispensable for ensuring robust system analysis and maintaining overall transmission reliability.
- Despite this being a longstanding issue faced by the Licensee, the challenge persists. Following the introduction of the PDMS portal, IndiGrid proactively approached the concerned authorities and successfully obtained access credentials. However, it is observed that event reporting on the portal remains inconsistent, and even where events are recorded, DRs and ELs are often not uploaded or made available.
- In view of the seriousness and recurring nature of this issue, IndiGrid humbly requests the forum's intervention to direct the concerned substation-owning utilities to ensure that DRs and ELs pertaining to any event are shared promptly, preferably within a few hours of occurrence.
- Timely availability of such critical data is essential not only for compliance purposes but also for safeguarding grid reliability and enabling effective operational decision-making.

Deliberations in the meeting

Indgrid raised concerns regarding non-availability of Disturbance Recorder (DR) and Event Recorder (ER) data after tripping incidents. The delay in receipt of DR/ EL impacts restoration and fault identification.

OCC Decision

- *All utilities are required to ensure mandatory upload of DR/EL on the PDMS portal within 24 hours in event of any fault. Non-compliance in this regard needs to be recorded and monitored regularly in PCC(Protection) forum.*
- *ERLDC was advised to regularly share the list of substations/utilities who are not providing DR/EL data, in PCC forum.*

2.10 Critical erosion by River Kamla Balan, at tower no 348 from both sides & line modification required at tower no 348 of 400 kV New Purnea-Muzaffarpur Line with provision of Pile foundation: Powerlinks

- *Tower No. 348, located on the west bank of the Kamla Balan River was observed for the strong water current of the river, and due scouring, severe erosion has occurred near the tower.*
- *Earlier, RRM protection work (revetment) had been provided for protection of tower, but the river scouring & soil erosion has developed again. During the inspection, it has further noted that the river flow towards the Leg C–D and Leg D–A sides is causing continuous erosion, resulting in damage to the B-C leg-side protection wall.*
- *Under the current circumstances, there is the 5 to 6 mtr water depth around the earlier protection wall which has created a significant risk to the stability of the tower, and with ongoing erosion, the tower may also be at risk of collapse in the future.*
- *In aforementioned scenario, To ensure safety & reliability of the line, we have option for Pile foundation in place of Normal foundation (@ just 3 mtr below the normal ground) provided earlier.*
- *Shutdown requested from 20th April to 25th May 2026 for pile foundation works.*

Deliberations in the meeting

Powerlinks delivered a concise presentation highlighting the following concerns:

- *Severe river erosion (Kamla Balan / Kosi branch) has taken place threatening stability of Tower No. 348.*
- *As per present condition, the tower is isolated with water flow on both sides with compromised foundation depth (~5.5 m vs original ~3 m). Risk also extends to 10–15 adjacent towers.*
- *Interim protection measures have been adopted to safeguard against tower collapse.*

ERLDC underscored the high system sensitivity during solar hours (due to NR-ER injection) and thus may aggravate the risk of N-1 violation.

OCC Decision

- ✓ *In view of criticality of the corridor and multiple shutdown requests in the same corridor around same time, OCC opined to convene a special meeting involving all stakeholders to finalize the planned shutdown schedule.*
- ✓ *All transmission utilities were advised to ensure early planning and timely intimation for outages of transmission elements.*

2.11 Review of Black Start Exercises of Hydro Stations of ER as per IEGC 2023 Compliance for the FY 2025-26 and associated Action Plan for Improvement :ERLDC

- As mandated by IEGC 2023, mock black start exercises have to be carried out for all black start capable generating units Annually. In compliance, black start exercises of all hydro stations of ER have been completed up to March 2026.
- Based on the outcomes of these exercises, corrective actions have been identified for cases where black start was unsuccessful. Additionally, for stations where black start was successful, certain improvement areas have been observed to enable faster and more reliable system restoration. Plant wise these action points and status is mentioned below, which need to be taken up by plants.

Sr. No	Plant/ Unit Name/ Date	Reason for Failure/Rectification	Remarks / Scope of Improvement
1	Tashiding Unit-1 12.12.2025 Unsuccessful	From Plant side line was extended and Frequency, voltage, angle all parameters were stable and within permissible synchronisation range but Rangpo end BCU for synchronisation was hanged so , synchronisation could not be achieved .	Subsequently, BCU synch check system at Rangpo was tuned by OEM and Mock blackstart Synchronisation was achieved for other plants. Proper periodic testing required for ensuring healthiness of existing BCU based Sync- facility. **However, for better and faster synchronisation it was recommended to install Auto synch facility at Rangpo**.
2	Dikchu Unit-1 11.03.2026 Unsuccessful	Sustained oscillation in plant side Frequency and voltage leading to continuous violation of Synchronisation criteria.	While doing blackstart during associated line charging mode (LCH), there was a persistent issue in the Governor (frequency control) and Exciter (voltage control) systems. Similar issue was faced during the last year mock drill where unit failed to maintain a stable voltage and frequency exhibiting sustained oscillations in both voltage and frequency. This indicates that the control loops are likely improperly tuned for "island mode. As a remedial measure, Dikchu was requested to formalise the issue with the OEM and perform internal response testing. Dikchu HEP must submit a comprehensive root cause analysis alongside all relevant testing documentation after which mock black start will be performed again.

3	<p>Jorethang Unit-2 04.02.2026</p> <p>Successful</p>	<p>Though the blackstart was successful, but the plant frequency exhibited continuous fluctuations during the line charging mode of operation, likely attributable to variations in penstock pressure.</p>	<p>Frequency fluctuations resulted in a delay in synchronization at the Rangpo end, with the synchronization process taking approximately 50 minutes to complete as generating unit was not able to maintain frequency difference within the acceptable limit of 0.02 Hz for a significant duration.</p> <p>Jorethang HEP is requested to take up the matter with the OEM to investigate the probable causes of the observed fluctuations. Appropriate corrective measures may be implemented based on the findings. Action taken report in this regard may be submitted.</p>
4	<p>Rongnichu Unit-1 & 2 16.03.2026</p> <p>Successful</p>	<p>The first attempt for Unit-1 failed due to GT Over-frequency (O/F) protection.</p>	<p>Successfully synchronized in subsequent attempts. The difference between grid and unit frequency remained within 0.02 Hz.</p>
5	<p>Chuzachen Unit-1 30.03.2026</p> <p>Successful</p>	<p>N/A</p>	<p>Unit -1 Completed successfully. However, Unit -2 Mock black start was attempted during the last year FY 2024-2025 was unsuccessful due to excitation system issue during Line charging Mode which needs to be checked and rectified and corrected by CHEP.</p>

Deliberations in the meeting

ERLDC apprised:

- ✓ Black start exercises of all hydro stations of ER have been completed up to March 2026 In compliance to IEGC 2023.
- ✓ Black start successful in majority of the stations except a few, as such, it was unsuccessful in Dikchu HEP due to oscillatory voltage/frequency in islanding mode while partially successful in Tashiding owing to issues in synchronization system.
- ✓ Jorethang plant also exhibited frequency fluctuations, which resulted in a delay in synchronization at the Rangpo end, and the synchronization process took approximately 50 minutes to complete as generating unit was not able to maintain frequency difference within the acceptable limit of 0.02 Hz for a significant duration .Jorethang HEP was requested to take up the matter with the OEM to investigate the probable causes of the observed fluctuations.
- ✓ Dikchu observed Sustained oscillation in plant side Frequency and voltage in islanding mode leading to continuous violation of Synchronisation criteria and it could not be synchronised. Dikchu HEP was requested to engage with OEM and resolve control system issues. A comprehensive root cause analysis alongside all relevant testing documentation after which mock black start will be performed again.

OCC Decision

- ✓ *Powergrid was advised to consider installation of auto-sync facility during SCADA upgradation at 400 kV Rangpo station as majority of hydro stations capable of blackstart are connected at Rangpo substation. In this regard, procurement of new BCU should be expedited.*
- ✓ *Appropriate corrective measures as mentioned and summarized above may be implemented. The effectiveness of the measures will be validated during the subsequent mock drill exercise.*

2.12 Data Collection for monitoring Pan-India Captive Generating Capacity: ERPC

In the meeting taken by **Secretary (Power)**, Govt of India on **17.12.2025**, it was decided that the State Chief Electrical Inspectors (CEIs) / State Load Despatch Centres (SLDCs) shall act as the nodal agencies for collection of **Captive Generation & Open Access** data for their respective States.

It was further decided that the **Regional Power Committees (RPCs)** shall act as the nodal coordinating agencies for consolidation and compilation of the data at the regional level on **monthly basis**.

Deliberations in the meeting

ERPC representative shared that data for the month of March 2026 received from all SLDCs except Odisha.

SLDC Odisha updated:

Data upto February 2026 has been submitted while data for March to be submitted shortly

OCC Decision

- *SLDC Odisha was urged to submit the pending captive generation data for March 2026 at the earliest.*
- *All SLDCs were advised to collate captive generation data of CPPs in their respective states and share it with ERPC secretariat on monthly basis. Relevant generation data of a particular month may be shared by 10th of the subsequent month.*

ADDITIONAL AGENDA

2.13 Modification of SPS-1000 Scheme at Talcher for Facilitating lower power order in HVDC Talcher –Kolar: ERLDC

- In the present system configuration, an SPS (Special Protection Scheme) is in place at Talcher STPP to safeguard the ER network against sudden disturbances in the event of double pole/single pole tripping of the Talcher–Kolar HVDC at NTPC Talcher. The existing SPS is designed to operate when the HVDC power order is above 1150 MW with various power order and pole tripping combinations ANDED with 400 kV Talcher -Meramundali Overloading (IMAX).
- However, in view of the changing power flow scenario between ER and SR, it was observed that during high generation conditions in SR with significant export, the HVDC Talcher–Kolar is required to operate at a power order below 1000 MW.
- In this regard, a meeting was convened on 15.07.2025 involving ERPC, NLDC, SRLDC and ERLDC, wherein the modified SPS logic was discussed and agreed upon. To address this, it was deliberated that when the HVDC power order is below 1150 MW, the SPS logic needs to be modified.

- It emerged from the discussion that revised SPS shall be decoupled from HVDC tripping whenever HVDC power order is below 1150 MW and will be triggered based on 400 Kv Talcher -Meramundali loading conditions, the SPS shall initiate generation reduction of 300 MW at Talcher.
- Further, the same was also deliberated in the 235th OCC meeting of ERPC held on 21.01.2026, particularly in the context of Talcher–Meramundali reconductoring work.
- To enhance network reliability and support lower HVDC power orders, it is proposed to implement modified System Protection Scheme (SPS) to support HVDC operations below 1150 MW. Please find the finalized logic diagram below for immediate implementation and records.

Table-1: Generation reduction Quantum through HVDC Talcher-Kolar (Existing + Modified logic)

	Talcher-Kolar power order (MW)	Reduction in generation				Remarks
		Unit-4	Unit-5	Unit-6	Total reduction quantum	
One pole trip & other in GRM + 400kV TSTPP-Meeramundali each CKt flow > I_{max}	1600-2000	0	150	450	600	Existing logic
	1450-1600	150	150	150	450	
	1300-1450	150	150	0	300	
	1150-1300	0	150	0	150	
400kV TSTPP-Meeramundali each CKt flow > I_{max}	0-1150				300	Modified logic
Bipole tripping + 400kV TSTPP-Meeramundali each CKt flow > I_{max}	1600-2000	150	150	450	750	Existing logic
	1450-1600	0	150	450	600	
	1300-1450	150	150	150	450	
	1150-1300	150	150	0	300	
	1000-1150	0	150	0	150	To be disabled
400kV TSTPP-Meeramundali each CKt flow > I_{max}	0-1150				300	Modified logic

Deliberations in the meeting

ERLDC submitted:

- *High RE generation in Southern Region necessitates backdown of NTPC Talcher during import from power surplus SR.*

- This also results in overloading of 400 kV Talcher–Meramundali line in ER.
- Thus there is need to operate HVDC Talcher-kolar bipole at less than 1000 MW.
- The original SPS logic was already discussed and agreed in ERPC forum.
- In the modified logic, generation back-down will be enabled at NTPC Talcher even when HVDC Talcher-kolar bipole operates below 1000 MW, treating the condition as equivalent to pole outage.

Modified SPS logic enclosed at **Annex B.2.13**

OCC Decision

OCC granted in-principle approval to the modified SPS at Talcher and thereby support HVDC operations at lower power level. The SPS shall be implemented only after necessary consent is received from SRPC.

2.14 Restoration of Barh–Kahalgaon Ckt-1 & 2: NTPC

- Barh–Kahalgaon Ckt-1 & 2 lines have been out of service since **02.04.2026** and are currently under scheduled outage up to **20.04.2026**.
- It is to be noted that Barh Super Thermal Power Station has a total of 8 transmission lines for power evacuation; however, Barh–Kahalgaon Ckt-1 & 2 are the **designated start-up power sources for the station** during outage conditions.
- Prolonged unavailability of these critical lines poses a significant risk to station start-up reliability and emergency restoration capability.
- In view of the above, the matter may be treated as **most urgent**, and all concerned are requested to prioritize and expedite restoration of these lines at the earliest, preferably well before the scheduled outage completion.

Deliberations in the meeting

NTPC submitted:

- Both circuits of Barh–Kahalgaon line are out of service since 2nd April 2026 due to NHA diversion works. This has significantly impacted start-up power availability for NTPC Barh station.

As informed by Powergrid ER-I, both the circuits will be restored by 20th April 2026.

OCC Decision

- ✓ POWERGRID was advised to restore both the circuits as per submitted timeline.
- ✓ OCC also laid emphasis on the provision of alternate start-up arrangements for thermal generating stations in ER.

2.15 Construction power for Darlipali Stage-II: NTPC

- NTPC has applied for 500 kVA power with TPWODL(Odisha DISCOM), and an estimate amounting to ₹31 lakhs has been submitted, which is currently under process for payment. The likely power drawl is expected to commence from June 2026.
- The power consumed for construction activities is required to be adjusted with the ex-bus of Stage-I. It is requested to kindly take up the matter with the concerned departments/authorities for necessary action
- The power shall be fed from the 11 kV Miscellaneous Switchgear (near FOPH Pump House) to the construction power network through two numbers of 5 MVA, 11/11.5 kV isolating transformers.

- BHEL has planned to draw construction power to the tune of 2.5 MVA. However, at present, they have requested 500 kVA due to limited ongoing activities. The requirement shall be increased progressively as per site needs.

Deliberations in the meeting

NTPC summarized the requirement of construction power for Darlipali Stage-II from Odisha DISCOM. This power consumed for construction activities will be adjusted with the ex-bus of Stage-I.

OCC Decision

- ✓ *OCC granted in-principle approval to the proposed scheme for drawl of construction power i.r.o Darlipali Stage-II. However, the necessary metering arrangement has to be done by NTPC Darlipalli and also NOC needs to be obtained from the concerned DISCOM prior to drawl of construction power.*
- ✓ *OCC referred the matter to upcoming TCC meeting for concurrence.*

2.16 Rescheduling of Unit-1 Overhauling:NTPC

- As per the Generator Maintenance Schedule submitted by NTPC Darlipali for FY 2026–27, the shutdown of Unit #1 (800 MW) was initially planned from 15th May 2026 to 28th June 2026 for carrying out Annual Overhauling (AOH) activities.
- However, as per the last OCC meeting decision, the shutdown of Darlipali Unit-1 (800 MW) was deferred beyond the peak summer period, with a recommendation to reschedule it after July 2026.
- Accordingly, based on a review of material readiness and contract availability, it is now proposed to undertake the Overhauling (OH) of Unit-1 from **20th August 2026** for a duration of **45 days**.

Deliberations in the meeting

OCC Decision

OCC approved the Overhauling (OH) of NTPC Darlipali Unit-1 from 20th August 2026 for a duration of 45 days.

2.17 Discrepancy in scheduling w.r.t Talcher Stage-1 :NTPC

- There is a discrepancy in the cumulative SG up to Mar-2026 (in REA of Mar-2026) due to the revision of cumulative SG up to the previous month, i.e., Feb-2026. The issue has been communicated to ERPC/ERLDC for correction of the SG Mail copy, which is attached.
- 10MW Talcher Solar plant, no Schedule punching on WBES on 11th Feb-2026, Consent from DVC is required.

Deliberations in the meeting

OCC Decision

- ✓ *The issue of discrepancy in REA (Regional Energy accounts) for January–March 2026 was referred to CCM for further deliberation.*
- ✓ *ERLDC and NTPC were advised to jointly verify relevant data and thereby the discrepancy i.r.o scheduling of Talcher Solar plant may be resolved bilaterally.*

2.18 Approval of Unit #1(Buxar Thermal Power Plant)Shutdown (12 +12 Days Total) for Performance Guarantee: SJVN

Tentative Timeline of **Shutdown**: : 01/05/2026 to 12/05/2026 and 28/05/2026 to 09/06/2026.

Coal Supply Chain Disruption

- **Current Status:** Coal supply chain disruption affecting fuel availability to our station
- **Impact:** Inadequate coal stocks to maintain continuous operation during extended shutdown period
- **Mitigation:** This shutdown aligns with coal availability, minimizing impact on grid stability

Performance Guarantee Test (PGT) Requirement

- **OEM Mandate:** Turbine manufacturer requires Performance Guarantee Test as per contract terms.
- **Objective:** Verify turbine efficiency, heat rate, and operational parameters against guaranteed.
- **Criticality:** Non-execution may lead to contractual penalties and warranty claims

Deliberations in the meeting

Buxar TPP representative informed:

- *The Unit#1 had been in shutdown since 11th April owing to coal supply disruption.*
- *Regarding 400 kV Buxar–Naubatpur line, Circuit-2 has been Charged while Circuit-1 is expected within 10 days.*

OCC Decision

SJVN was advised to ensure adequate coal stock as well as transmission readiness to avoid power evacuation constraints.

2.19 Shutdown request from BRBCL

This is to inform that **BRBCL Unit-3 (250 MW)** is proposed to be taken under **planned overhauling for a duration of 35 days** from **13.07.2026 to 16.08.2026**.

The scope of overhauling includes the following major activities:

- Boiler inspection and maintenance
- Turbine Generator (TG) bearing inspection
- Main Oil Pump (MOP) inspection
- Generator inspection
- Inspection and servicing of all turbine valves
- Barring gear and hydro motor inspection

Deliberations in the meeting

OCC Decision

As major share of power is allocated to Indian Railways, the proposed outage of BRBCL Unit-3 (250 MW) for 35 days may be availed subject to consent from Indian Railways.

2.20 Continuous S/D of 400kV D/C Binaguri-New Purnea TL (Ckt-1 & Ckt-2): POWERGRID

- ✓ Continuous S/D is required for carrying out diversion of tower location no.-94 of 400kV D/C Binaguri-New Purnea TL vulnerable due to change of course of Parman River.
- ✓ Location no.-94 of 400kV D/C Binaguri-New Purnea TL have become vulnerable due to change in course of River Parman. Last year the location No. 94 was somehow saved by providing river bank protection with Geo-synthetic Reinforced wall (GRW) to protect from soil erosion. But due to severe flood during Oct-2025, further soil erosion observed from bank of river Parman resulting in vulnerability to Tower No.-94.
- ✓ As a temporary protection measure, tree log piling with Polyester Geo-bag has been laid all along the river bank adjacent to Tower No.-94.
- ✓ However, considering the last year trend and anticipating future vulnerability, it has been felt prudent to permanently shift the tower Location No. 94 on Pile foundation. Presently Pile Foundation work is in progress.
- ✓ During new tower erection at Loc No.-94 (Top part and X-arm fixing) & stringing work we shall be requiring continuous S/D of 400kV D/C Binaguri-New Purnea TL (Ckt-1 & Ckt-2) for 10 days tentatively w.e.f. 20.06.2026 to 04.07.2026.

PHOTO DURING LAST YEAR FLOOD DTD. 11.10.2025



PRESENT PHOTO DTD 15.04.2026



Deliberations in the meeting

OCC Decision

- ✓ In view of criticality of the corridor and multiple shutdown requests in the same corridor around same time, OCC opined to convene a special meeting involving all stakeholders to finalize the planned shutdown schedule.

2.21 Certification of DVC's 400 kV STU Lines as Non-ISTS Lines Carrying ISTS Power: DVC

- In line with the provisions under Para 2.1.3 of Annexure-I of the **CERC (Sharing of Inter State Transmission Charges & Losses) Regulations, 2010**, Eastern Regional Power Committee (ERPC) certified certain STU lines of DVC as non-ISTS lines carrying ISTS power (*vide letter no. ERPC/MS/2017/1973 dated 24.08.2017*) because of more than 50% of ISTS flow in these lines. Subsequently, ERPC also certified the availability of these lines for the period FY 2017–18 to FY 2021–22. Copies of the above are placed under - **Annexure-I**
- However, such provision for certification of non-ISTS lines as ISTS lines by RPCs had been omitted from the **Central Electricity Regulatory Commission (Sharing of Inter-State Transmission Charges and Losses) Regulations, 2020**, implemented with effect from 01.11.2020. Subsequently, from Nov'20 onwards, utilities would be required to approach to CERC for such certification.
- Further, as per the provision under Clause 93 of the CERC (Terms and Conditions of Tariff) Regulations, 2024, **CEA has been entrusted with the certification of non-ISTS lines carrying inter-State power based on recommendations of STU and RPC**, subject to confirmation of regular and permanent flow by CTU in consultation with RPC and RLDC. Thus, from FY-2024 onwards, utilities need to approach CEA for necessary certification for STU lines as Non-ISTS Lines carrying ISTS Power.
- In view of the above regulatory framework and as clarified by CEA vide letter dated 30.03.2026, the request for certification of inter-state transmission lines as deemed ISTS lines for the tariff period 2019-24 does not fall within the applicability period of the above-mentioned regulations.
- Accordingly, CEA has suggested the following :
 - ✓ For the period April 2019 to October 2020, DVC may approach ERPC for certification – Ref. **CERC (Sharing of Inter State Transmission Charges & Losses) Regulations, 2010**
 - ✓ For the period November 2020 to March 2024, DVC may approach CERC for necessary consideration – Ref. **Central Electricity Regulatory Commission (Sharing of Inter-State Transmission Charges and Losses) Regulations, 2020**
- In light of the above, DVC hereby requests for certification of the following 400 kV STU lines as non-ISTS lines carrying ISTS power for the period April 2019 to October 2020 (Tariff Period FY 2019–24):
 - A. Raghunathpur (RTPS) – DSTPS D/C line
 - B. Raghunathpur (RTPS) – Ranchi (Quad) D/C line

Deliberations in the meeting

OCC Decision

ERLDC was advised to carry out the necessary power flow study to ascertain flow pattern of ISTS power through non-ISTS lines of DVC during the period April 2019 to October 2020. This detailed report will be shared with ERPC for reference. As certification of these non-ISTS lines has significant financial implications, OCC opined to expedite the process.

2.22 Declaration of high inflow season for Hydro-generating stations of Eastern Region for calculation of RTDA Accounts for FY 2026-27: ERPC

•As per the minutes of 3rd meeting of CERC with RPCs and further in line with the discussions held in the 45th CCM meetings, the high inflow season for hydro generating stations is to be finalized in the OCC meetings.

•Subsequently, as per the decision of 218th OCC meeting, OCC opined that in case of actual spillage more than 10 days during a particular month, the corresponding months shall be considered as high inflow period for respective hydro generating units of ER. This shall be decided based on submitted data for last 3 years and should be henceforth considered in calculation of RTDA accounts of FY 2026-27.

Deliberations in the meeting

OCC Decision

Based on spillage data as received from various hydro stations for the last 3 years , OCC approved the hydro station wise inflow period for FY 2026-27 as follows:

Hydro Station	High Inflow Period	Months
Chuzachen HEP	May, June, July, August, September	05 months
Dikchu HEP **	May, June, July, August, September	05 months
Rongnichu HEP	June, July, August, September	04 months
Jorethang Loop HEP	June, July, August, September	04 months
Tashiding HEP	June, July, August, September	04 months
Rangit HEP	June, July, August, September, October	05 months
Teesta V HEP *	June, July, August, September, October	05 months

**Since Teesta-V HEP is under forced outage of long duration from Oct'23 onwards, FY 2021-22, 2022-23 and 2023-24 are considered for declaration of high inflow period of FY 2026-27.*

*** For Dikchu HEP, FY 2022-23, 2023-24 and 2025-26 is considered as data is not available for FY 2024-25. The Dikchu plant was flooded on 4th October 2023 and hence the reservoir has been kept empty by opening the gates allowing virgin flow of Dikchu river. Hence spillage data is not available from 4th October 2023 onwards.*

2.23 Issuance of Trial Run Certificate for 400 kV Farakka–Kahalgaon-I Line: ERLDC

- 400 kV Farakka–Kahalgaon-I line was charged on 17.03.2026 after completion of reconductoring work by POWERGRID. However, line is presently not capable of carrying the upgraded HTLS ampacity, due to the pending jack bus upgradation work at NTPC Farakka end which is part of the NTPC scope of work.
- In this regard, a meeting was convened on 25th March 2026 to deliberate on the proposed shutdown plan for a period of 18 days starting 27th Mar'26 to carry out pending reconductoring work of the Jack Bus at NTPC Farakka. It was decided by the forum, that the proposed shutdown cannot be permitted at present and it will be reviewed post summer 2026.
- Meanwhile, POWERGRID has requested issuance of Trial Run Certificate for the reconducted line for the period from 17.03.2026 (13:48 hrs) to 18.03.2026 (13:48 hrs). Since the bays are not under the scope of POWERGRID and the reconductoring work under their scope has been completed, ERLDC is processing the request for issuance of Trial Run Certificate, which will be issued shortly.
- Members may note the above and NTPC Farakka may update the status of the pending upgradation work and expected timeline for completion.

Deliberations in the meeting

Members note

3. PART-C: ITEMS FOR INFORMATION

3.1. ER Grid performance during March 2026

The average and maximum consumption of Eastern Region and Max/Min Demand (MW), Energy Export for the month March -2026 were as follows:

AVERAGE CONSUMPTION (MU)	MAXIMUM CONSUMPTION(MU)/ DATE	MAXIMUM DEMAND (MW)	MINIMUM DEMAND (MW)	SCHEDULE EXPORT	ACTUAL EXPORT
		DATE / TIME	DATE / TIME	(MU)	(MU)
548 MU	599.8 MU, 30.03.2026	27876 MW, 31.03.2026 at 19:00 Hrs.	16477 MW, 28.03.2026 at 02:58 Hrs.	4225	4405

Deliberations in the meeting

The grid performance of ER for the month of March, 2026 was highlighted.

3.2. Non-Submission of FRC data in stipulated time-frame: ERLDC

Adhering to IEGC clauses 30.8 and 30.10.(a) to 30.10.(q), generating stations within the Eastern region are required to submit essential data to ERLDC within two days of receiving a notification regarding a reportable frequency event. Additionally, according to clause 30.10.(n), all control areas within the eastern region must assess their frequency response characteristics and share the evaluation, along with high-resolution data, with the ERLDC. Therefore, timely submission of primary response data is crucial for compliance with the IEGC.

Hence all are again requested to follow the stipulated timeline and submit the data to ERLDC and also fill the google sheet below to include the email address where notifications of reportable events should be sent.

The latest data receipt status is given below: (as on **05.03.2026**):

STATIONS		14.01.2026 13:38 hrs	14.01.2026 14:05 hrs	14.01.2026 14:09 hrs	30.01.2026 11:08 hrs	13.02.2026 12:14 hrs	22.02.2026 22:56 hrs	22.02.2026 23:00 hrs	03.03.2026 11:42 hrs
FSTPP #STG 1 & 2	ISGS								
FSTPP # STG 3	ISGS								
KhSTPP #STG 1	ISGS								
KhSTPP #STG 2	ISGS								
TSTPP #STG 1	ISGS								
Barh stage-1	ISGS								
Barh stage-2	ISGS								
BRBCL	ISGS								
Darlipalli	ISGS								
North Karanpura	ISGS								
NPGC	ISGS								
TEESTA V	ISGS								
PVUNL	ISGS								
Dikchu	IPP								
IBEUL (JSW UTKAL)/INDBHARAT	IPP								
GMR	CPP								
MPL	CPP								
ADHUNIK	CPP								
JITPL	CPP								
TEESTA III	CPP								
Bihar	STATE								
Jharkhand	STATE								
DVC	STATE								
OPTCL	STATE								
WB	STATE								
Updated as on	07.04.2026								
	Received								
	Not Received								
	Plant Out								
	Data freeze at plant								

Hence all are again requested to follow the stipulated timeline and submit the data to ERLDC and also fill in the google sheet below to include the email address where notifications of reportable events should be sent.

https://docs.google.com/spreadsheets/d/1slvAOmQIEQVIMn0LnB78eKMa2sz2QYICZ-sPEpeV_jk/edit?usp=sharing

Deliberations in the meeting

OCC Decision

- ✓ All generators were advised to regularly share high resolution data against each reportable frequency event with ERLDC on time to facilitate accurate assessment of FRP for respective control areas.
- ✓ All generating utilities were also urged to update the google sheet (link mentioned above) with email address where notifications of reportable events will be shared.

3.3. Regarding Non-Submission of Forecasting Data from States: ERLDC

Clause 2 of Regulation 31 of IEGC 2023 has mandated all the SLDCs to timely submit the demand estimate data to the respective RLDC and RPC.

Current data submission status is given in the table below: Hence it is again requested to all the concerned for timely submission of demand estimation data to ERLDC. This collaboration is essential for effective planning and preparedness to meet the region's electricity demands efficiently and reliably. Latest Forecast and Resource Adequacy Data receipt status at ERLDC is shown below:

4. PART-D: OPERATIONAL PLANNING

4.1. Major Thermal Generating Units/Transmission Element outages/shutdown in ER Grid (as on 05-03-2026)

SL No	STATION	STATE	AGENCY	UNIT NO	CAPACITY (MW)	REASON(S)	OUTAGE DATE
1	MEJIA TPS	DVC	DVC	7	500	Capital overhauling.	26-02-2026
2	JSWEUL	ODISHA	JSWEUL	1	350	Cooling Water line Leakage	09-04-2026
3	KHSTPP	BIHAR	NTPC	3	210	Boiler Tube Leakage	09-04-2026
4	FSTPP	WEST BENGAL	NTPC	3	200	Problem in Excitation System	06-04-2026
5	JSWEUL	ODISHA	JSWEUL	2	350	EH oil leakage	04-04-2026
6	NORTH KARANPUR A	JHARKHAND	NTPC	2	660	High vibration and abnormal sound from HP Turbine	24-03-2026
7	KODERMA	DVC	DVC	1	500	Low Forward Power (C&I problem)	09-04-2026
8	DPL	WEST BENGAL	DPL	7	300	Boiler furnace pressure low	06-04-2026
9	SAGARDIGH I	WEST BENGAL	WBPDCCL	5	660	Tripped on boiler tube leakage	04-04-2026
10	BARAUNI TPS	BIHAR	NTPC	8	250	Turbine bearing temperature high	09-03-2026
11	IB.TPS	ODISHA	OPGC	1	210	Air preheater problem	06-03-2026
12	MEJIA TPS	DVC	DVC	2	210	Stator earth fault	07-01-2026

Major Generating stations Out on Reserve Shutdown due to low system demand:

SL No	STATION	STATE	AGENCY	UNIT NO	CAPACITY (MW)	REASON(S)	OUTAGE DATE
NA							

Hydro Unit Outage Report: -

S. NO	STATION	STATE	AGENCY	UNIT NO	CAPACITY (MW)	REASON(S)	OUTAGE DATE
1	RANGIT HPS	SIKKIM	NHPC	1	20	Annual Maintenance	25-03-2026
2	BURLA HPS/HIRAKUD I	ODISHA	OHPC	5	43.65	Annual Maintenance	19-Jan-2026
3	BALIMELA HPS	ODISHA	OHPC	5	60	Repair and maintenance work	16-Jan-2025
4	BALIMELA HPS	ODISHA	OHPC	6	60	Initially unit was out due to Severe water leakage from turbine, later unit was taken under Repair and maintenance work from 00:00 hrs of 16.01.25	06-Jan-2025
5	CHIPLIMA HPS / HIRAKUD II	ODISHA	OHPC	1	24	Capital Overhauling	15-Dec-2023
6	TEESTA HPS	SIKKIM	NHPC	1	170	Sudden cloudburst at glacier fed LOHNAK Lake followed by huge inrush of water in Teesta River and damage of Teesta III Dam & downstream Powerhouses	04-Oct-2023
7	TEESTA HPS	SIKKIM	NHPC	2	170		04-Oct-2023
8	TEESTA HPS	SIKKIM	NHPC	3	170		04-Oct-2023
9	TEESTA STG III Hep	SIKKIM	TUL	1	200		04-Oct-2023
10	TEESTA STG III Hep	SIKKIM	TUL	2	200		04-Oct-2023
11	TEESTA STG III Hep	SIKKIM	TUL	3	200		04-Oct-2023
12	TEESTA STG III Hep	SIKKIM	TUL	4	200		04-Oct-2023
13	TEESTA STG III Hep	SIKKIM	TUL	5	200		04-Oct-2023
14	TEESTA STG III Hep	SIKKIM	TUL	6	200		04-Oct-2023
15	U. KOLAB	ODISHA	OHPC	2	80		Heavy Leakage in guide vane
16	BURLA HPS/HIRAKUD I	ODISHA	OHPC	7	37.5	Abnormal sound from slip ring area	18-Sep-2025

Deliberations in the meeting

Members noted.

4.2. Long outage report of transmission Element (MORE THAN 01 WEEK) (As on 05.04.2026):

Transmission Element / ICT	Outage From	Reasons for Outage
220/132 KV 100 MVA ICT II AT LALMATIA	22-01-2019	220/132KV, 100MVA Transformer (NTPC side) is charged on 07.02.2024 from HV side on no load. Now, it is in idle charged condition
220KV-FSTPP-LALMATIA-I	21-04-2021	Two nos. of tower collapsed on 29.05.2024 near to Lalmatia GSS in the Loc. No. 246 & 247. 220KV S/C Farakka-Lalmatia Transmission Line is in anti-theft charging condition from Loc no 248 (Lalmatia end) to Loc no 33. Foundation, erection, and stringing progress from loc 1 to 32
132KV-BARHI-RAJGIR-1	25-03-2023	Dismantling of tower no. 227, 228, and 229 crossing the premises of Mahabodhi Cultural centre along with Destraining of conductor of both circuits and Earth wire between tension tower no. 218-237 in same line. The lines from Barhi (DVC) will be terminated at Barachatti (BH) and new line to be constructed from Barachatti to Rajgir (BH)
132KV-NALANDA-BARHI(DVC)-1	25-03-2023	Dismantling of tower no. 227, 228, and 229 crossing the premises of Mahabodhi Cultural centre along with Destraining of conductor of both circuits and Earth wire between tension tower no. 218-237 in same line. The lines from Barhi (DVC) will be terminated at Barachatti (BH) and new line to be constructed from Barachatti to Nalanda (BH)
400KV-RANGPO-TEESTA-V-1	04-10-2023	Tower near gantry of Teesta V HEP collapsed during GLOF event in Oct 2023 also leading to damage in powerhouse. Tower subsequently erected on 15.06.2024. Teesta V HEP GIS damaged due to hill sinking on 20.08.2024. Presently, GIS under restoration and generation expected by 31.03.2026.
400KV-RANGPO-TEESTA-V-2	04-10-2023	Tower near gantry of Teesta V HEP collapsed during GLOF event in Oct 2023 also leading to damage in powerhouse. Tower subsequently erected on 15.06.2024. Teesta V HEP GIS damaged due to hill sinking on 20.08.2024. Presently, GIS under restoration and generation expected by 31.03.2026.
132KV-CHANDIL-MANIQUEI-1	05-06-2024	Power assistance withdrawn
400KV/220KV 315 MVA ICT 1 AT NORTH KARANPURA	12-09-2024	Tripped on Differential protection
400KV/220KV 315 MVA ICT 1 AT TSTPP	01-11-2024	Tripped on PRD protection. Current status: The failed transformer has reached the vendor, the repair scope has been finalized, the PR is created, and the PO is in the advanced stage of processing. The repair, transportation, installation,

		and commissioning are expected to take about six months, with the unit likely to be available by 30.06.2026. A spare 315 MVA ICT on loan from PGCIL is being explored, and their response is awaited.
132KV-PATRATU-PATRATU-1	16-11-2024	Taken out due to Rail-way diversion and height raising work between loc 11-12, the bottom conductor of Ckt#2 has been swapped with the middle phase conductor of Ckt#1 (which was under S/D since long). Currently Ckt-1 is anti-theft charged from DVC end. -As a long-term measure, DVC has sought two nos' of 132kV bays at newly constructed 400/220/132kV S/S of JUSNL at Patratu (JH) for termination of the lines.
400KV/220KV 315 MVA ICT 2 AT MEJIA-B	20-01-2025	315 MVA ICT-2 at MTPS-B got damaged while charging from 220kV GIS bay. New procurement of ICT has been taken up & installation of the same may complete by end of Mar'28.
400KV-DIKCHU-RANGPO-2	05-08-2025	Damaged insulator replacement work. While charging the line bus bar protection operated at Dikchu. Issue in GIS chamber of Y ph Isolator between line cb and bus 2, Powder formation inside isolator chamber, Revival Expected by December 25 as per availability of GE person. Presently negotiation in place for offer
400KV MAIN BUS - 2 AT DIKCHU	05-08-2025	Bus bar protection operated, Issue in GIS chamber of Y ph Isolator between Rango ckt 2 line cb and bus 2, Powder formation inside isolator chamber, Revival Expected by December 25 as per availability of GE person. Presently negotiation in place for offer
220KV-PATNA-KHAGAUL-1	24-09-2025	LBB relay operated during rectification of DC grounding defect by M/S KRR at GSS khagaul. Earlier w.e.f 02-08-2025 12:06 Hrs, Tower No. 63 has bent significantly on one side
220KV-DALTONGANJ-LATEHAR(JUSNL)-2	23-10-2025	To avoid overloading of 400/200 kV ICT-I at Latehar
220KV-BIDHANNAGAR-WARIA-1	29-10-2025	To control loading of 220 kV Waria-Mejia D/C (Anti-theft charged from Waria end.)
220KV-BIDHANNAGAR-WARIA-2	29-10-2025	Initially line was opened to control line loading. In between B-phase CT Blast at Bidhannagar end. Now Line is charged as anti-theft from Waria end to control loading of 220 kV Waria-Mejia D/C.
220KV-BALIMELA-UPPER SILERU-1	21-11-2025	Idle charged from U. Sileru end. Power drawl by Odisha halted due to non-concurrence by Andhra Pradesh.
132KV-MADHEPURA (BH)-SAHARSA-1	18-12-2025	To control the line loading. Line kept idle charged from Saharsa.
220KV-RAJARHAT-NEW TOWN(AA-II)-2	08-02-2026	For cable swapping job with RAJARHAT-NEWTOWN IIC-2

132KV-PATRATU-PATRATU-2	09-02-2026	Power assistance withdrawn
132KV-KHSTPP-SABOUR-1	10-02-2026	For Reconductoring work in transmission line
400KV/220KV 315 MVA ICT 1 AT KODERMA	10-02-2026	DGA violation -rising actylene trend
132KV-RANGIT-SAGBARI-1	28-02-2026	Necessary jumpering modification at Sagbari station (EPDS)
400KV-TEESTA-III-RANGPO-1	15-03-2026	Rangpo: B_N, DEF, 0.68 kA
765KV-JHARSUGUDA-DHARAMJAIGARH-3	16-03-2026	For diversion of existing 765kV D/C Jharsuguda – Dharamjaygarh Ckt 3&4, due to upcoming railway line of IRCON
765KV-JHARSUGUDA-DHARAMJAIGARH-4	16-03-2026	For diversion of existing 765kV D/C Jharsuguda – Dharamjaygarh Ckt 3&4, due to upcoming railway line of IRCON
HVDC 800KV ALIPURDUAR (PG) Pole 3	19-03-2026	H/T ON VOLTAGE REGULATION
HVDC 800KV ALIPURDUAR (PG) Pole 4	19-03-2026	H/T ON VOLTAGE REGULATION
132KV-BANKA (PG)-SULTANGANJ-1	19-03-2026	For reconductoring work in transmission line.
400KV-BINAGURI-NORBUGANG-1	30-03-2026	R/I at Binaguri: R_N, FC 3.3 kA, FD 109.16 km [Fault in Bhutan jurisdiction]
220KV-KATAPALLI-BOLANGIR(PG)-1	31-03-2026	For system requirement power order change

Deliberations in the meeting

Members noted.

4.3. Commissioning of new units and transmission elements in Eastern Grid in the month of March -2026

The details of new units/transmission elements commissioned in the month of March-2026 based on the inputs received from beneficiaries:

NEW ELEMENTS COMMISSIONED DURING MARCH, 2026							
उत्पादन इकाइयाँ / GENERATING UNITS							
क्र. सं. SI No.	स्थान Location / Pooling Station	मालिक/यूनिट का नाम OWNER/UNIT NAME	यूनिट संख्या/स्रोत Unit No/Source	संकलित क्षमता (मेगावाट) Capacity added (MW)	कुल/स्थापित क्षमता (मेगावाट) Total/Installed Capacity (MW)	दिनांक DATE	टिप्पणी Remarks

1	Patratu, Jharkhand	PVUNL - UNIT 2	2/Coal	800	1600	17-03-2026	First time unit synchronisation
आई.सी.टी./जी.टी./एस.टी / ICTs/ GTs / STs							
क्र. सं. SI No.	एजेंसी/मालिक Agency/Owner	उप-केन्द्र SUB-STATION	आईसीटी संख्या ICT NO	वोल्टेज (केवी) Voltage Level (kV)	क्षमता (एमवीए) CAPACITY (MVA)	दिनांक DATE	टिप्पणी Remarks
1	NTPC	NTPC KAHALGAON	ICT 3	400KV/132KV	200	11-03-2026	First time idle charge from 400 kV side
2	NTPC	NTPC KAHALGAON	ICT 4	400KV/132KV	200	11-03-2026	First time idle charge from 400 kV side
3	Powergrid Odisha Projects	JEYPORE	ICT 1	400KV/220KV	315	13-03-2026	A new 315 MVA ICT has been installed as a replacement for the old 3×105 MVA ICT#1 at Jeypore Substation, which had completed over 32 years of service and showed deviations in multiple test parameters.
4	DVC	KODERMA	ICT 2	400KV/220KV	315	05-03-2026	One 400/220/33 kV, 315 MVA ICT at Koderma TPS (DVC) was damaged on 02.06.2025. OCC approved utilization of a spare 315 MVA, 400/132/33 kV transformer from the ER pool at PGCIL Muzaffarpur Substation for Koderma TPS.
प्रेषण लाइन / TRANSMISSION LINES							
क्र. सं. SI No.	एजेंसी/मालिक Agency/Owner	लाइन का नाम LINE NAME	लंबाई (किमी) Length (KM)	कंडक्टर प्रकार Conductor Type	दिनांक DATE	टिप्पणी Remarks	
NIL							

लिलो / प्रेषण लाइन की पुनर्व्यवस्था / LILO/RE-ARRANGEMENT OF TRANSMISSION LINES						
क्र. सं. SI. No.	एजेंसी/मालिक Agency/Owner	लाइन का नाम / लिलो पर Line Name/LILO at	लंबाई (किमी) Length (KM)	कंडक्टर प्रकार Conductor Type	दिनांक DATE	टिप्पणी Remarks
1	PGCIL	400KV-FSTPP-KHSTPP-1	94.225	HTLS Conductor	17-03-2026	The line is owned by PGCIL, while the bays at both ends are owned by NTPC. Reconductoring of the line along with associated line-side equipment has been completed(PGCIL Scope). The bays at both ends (NTPC) have also been uprated in line with the revised line rating. However, the reconductoring of the jack bus at Farakka is yet to be completed. Accordingly, the loading on the line shall be restricted to 850 MW until completion of the jack bus reconductoring at Farakka.
बस/लाइन रिएक्टर / BUS/LINE REACTOR						
क्र. सं. SI. No.	एजेंसी/मालिक Agency/Owner	एलेमेंट का नाम Element Name	उप-केन्द्र SUB-STATION	रेटिंग (एमवीएआर) Rating (MVAr)	दिनांक DATE	टिप्पणी Remarks
NIL						
एच.वी.डी.सी/ए.सी फिल्टर बैंक/फैक्ट्स डिवाइस संबद्ध प्रणाली / HVDC /AC Filter bank / FACTS DEVICE associated System						
क्र. सं. SI. No.	एजेंसी/मालिक Agency/Owner	एलेमेंट का नाम Element Name	उप-केन्द्र SUB-STATION	वोल्टेज (केवी) Voltage Level (kV)	दिनांक DATE	टिप्पणी Remarks
NIL						
बस - बे / BUS - BAYS						

क्र. सं. SI. No.	एजेंसी/मालिक Agency/Owner	एलेमेंट का नाम Element Name	उप-केन्द्र SUB-STATION	वोल्टेज (केवी) Voltage Level (kV)	दिनांक DATE	टिप्पणी Remarks
1	NTPC	400KV MAIN BAY OF 200 MVA ICT-03 AT KAHALGAON (MAIN-II)	NTPC KAHALGAON	400	11-03-2026	
2	NTPC	400KV MAIN BAY OF 200 MVA ICT-04 AT KAHALGAON (MAIN-II)	NTPC KAHALGAON	400	11-03-2026	
3	NTPC	400KV MAIN BAY OF KHSTPP-1 AT FSTPP	NTPC FSTPP	400	18-03-2026	
4	NTPC	400KV MAIN BAY OF FSTPP I AT KHSTPP	NTPC KAHALGAON	400	26-03-2026	

Deliberations in the meeting

Members noted.

4.4. UFR operation during the month of March 2026

Frequency profile for the month as follows:

MONTH	MAX	MIN	% LESS IEGC BAND	% WITHIN IEGC BAND	%MORE IEGC BAND
	(DATE/TIME)	(DATE/TIME)			
March 2026	50.5 (on 21-Mar-26 at 13:01 Hrs.)	49.42 (on 03-Mar-26 at 18:52 Hrs.)	6.2	74.3	19.5

Hence, no report of operation of UFR has been received from any of the constituents.

Deliberations in the meeting

Members noted.

Meeting ended with a vote of thanks to the chair.











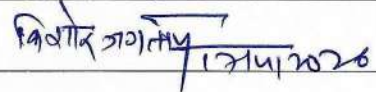

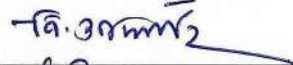
Annex-A

Participants in 238th OCC Meeting

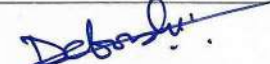
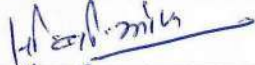
Venue: ERPC Conference Hall, Kolkata

Time: 10:30 Hrs.

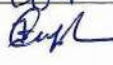
Date: 17.04.2026 (Friday)









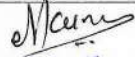
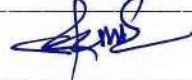

Sl.	Name	Designation	Organisation	Contact No.	E-mail Id	Signature
1	K.B. Jagtap	Member Secretary	ERPC		mserpc-power@nic.in	
2	S Banerjee	Executive Director	ERLDC			
3	D. BISWAS	GM	ERLDC	9484740041	dbiswas@grid-india.in	
4	B. Achari	DGM	ERLDC	7003472016	bilash.achari@grid-india.in	
5	MANAS DAS	DGM	ERLDC GRID-INDIA	9007070925	manasdas@grid-india.in	
6	ALOK PRATAP SINGH	C.M.	ERLDC GRID-INDIA	9007285390	apsinghe@grid-india.in	
7	RAKESH KUMAR PRAOCHAN	Ch. Mgr.	ERLDC GRID-INDIA	9831337570	rkpradhan@grid-india.in	
8	CHANDAN MALLICK	Ch. mgr.	ERLDC GRID-INDIA	7278756275	chandamallik@grid-india.in	
9	DEBORSHI CHAKRABORTY	DGM	NTPC KALKAJI	9650991026	deborshi.chakraborty@ntpc.co.in	
10	C. B. OJHA	AGM	NTPC ER-II HR. PATNA	9650900709	CHANDRABHUSHAN OJHA@NTPC.CO.IN	
11	Avinash Shukla	DGM	BKBL	945307986	AVINASH SHUKLA@NTPC.CO.IN	
12	Prasanna Kumar Sahoo	AGM	ER-II HQ, Bhubaneswar	8118052430	Prasanna.sahoo@ntpc.co.in	
13	B. Vishal Singh	DGM	NTPC NORTH KALKAJI	9423877770	bvishalsingh@ntpc.co.in	
14	Jaydeep Sengupta	ACE	WBSETCL	9434910547	cpd.wbsetcl@gmail.com	
15	Preetam Banerjee	ACE	WBSEDCL	7003871189	ace.wbaldc@wbsetcl.in	

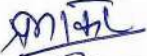
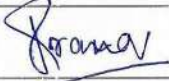
Participants in 238th OCC Meeting

Venue: ERPC Conference Hall, Kolkata

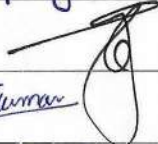
Time: 10:30 Hrs.

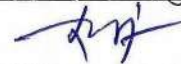
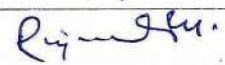
Date: 17.04.2026 (Friday)

Sl.	Name	Designation	Organisation	Contact No.	E-mail Id	Signature
16	Rajat Kr. Koley	Sr. Mgr (PS)	WBPDCL	9474860642	rk.koley@wbpdcl.co.in	
17	NISHANT KUMAR	DGM (ORM)	DMTCL-SEL	7987210324	nishant.kumar@energy-sel.com	
18	JANPA TIH GUMMANI	EE POWER DEPT.	POWER DEPT. SIKRI N.	85530 85909.	janpas.tamang631@gmail.com	
19	DEBANSUJEE	DGM (SO)	CEISC	9163312742	delsandi.de@nptcl.in	
20	Manas Guha	DGM (E) In	DPL	8509267341	m.guha@dpl.net.in.	
21	Prabhakar Kishore	GM (E)	STPL	9471001133	p.kishore@sjvn.nic.in	
22	Pranav Rathore	AM (Reg)	IndiGrid	9971196469	Pranav.rathore@indigrid.com	
23	Diptikanta Panda	Manager	GMR	8114918762	Diptikanta.Panda@ gmrgroup.in	
24	Susil K. Swain	AGM	GMR	7894450371	Susil.Swain@gmrgroup.in	
25	PIYUSH RAI	Sr. Manager	JPL	8947902213	Sales.pawar@jindalgroup.com	
26	GAGAN KUMAR	EEE	SLDC BSPTU	7992486100	gagankumishra@gmail.com	
27	TUNESHWAR KUMAR	Sr. Manager	STU, JUSNL	9431190306	tuneshwarkumar@gmail.com	
28	Raju Kachhap	Sr. Manager	SLDC Ranchi	7783087568	rajmailme82@gmail.com	
29	Rajendra Prasad	EEE.	TVNL	9030049936	rajendra.prasad@ tvnl.in	
30	Subrat Swain	D.M	ERLDC	8457890964	SubratSwain@grid-india.in	

Participants in 238th OCC Meeting

Venue: ERPC Conference Hall, Kolkata

Time: 10:30 Hrs.

Date: 17.04.2026 (Friday)





Sl.	Name	Designation	Organisation	Contact No.	E-mail Id	Signature
31	KAVITA PARIHAR	GM	ERLDC	9958114989	kavita@grid-india	
32	Jyoti Krishna Panda	AEE	ERPC	9151621295	jkpanda.cea@gov.in	 17/04/26
33	Santosh Kumar Panda	Manager	DVC LDC	6370134794	santosh.panda@dvc.gov.in	 17/04/26
34	Sudeep Kumar	DHM	POWERGRID.ERL	9431820338	sudeep.kumar@powergrid.in	
35	Prosen Mallik	DCRM	POWERGRID.ER-2	9434713582	prosen.mallik@powergrid.in	
36	Sanjay Kumar Sharma	Sr GM	DVC LDC	9434539423	Sanjay.Sharma@dvc.gov.in	
37	Manjunathan	ED	ERPC	9992223842	manjunathan.cea@gov.in	
38	PRATHAN KUMAR	EE	ERPC	8076873558	PrathanKumar.cea@nic.in	
39	D.K. Khentia	AD	ERPC	7683889161	d.k.khentia.cea@gov.in	
40	I. K. Mehra	Dir/SE	ERPC	9810688789	ikmehra@nic.in	
41	A. Basu	EE	ERPC	7020939184	abasu.kubep@grid.com	
42	Brayesh Shukla	Group Head (O&M) ER	POWERLINKS	9800013837	brayesh.shukla@tatapower.com	 17/04/26
43	VIKRANT VISHAL	Sr Manager (E)	DVC Commercial	9973710860	vikrant.vishal@dvc.gov.in	
44	M. S. Chatterjee	DHM (Commercial)	DVC	8420249355	m.s.chatterjee@dvc.gov.in	
45	Jayanta Boro	DGM (Elet)	NTPC	7637003516	jayantaboro@ntpc.co.in	

Participants in 238th OCC Meeting

Venue: ERPC Conference Hall, Kolkata

Time: 10:30 Hrs.

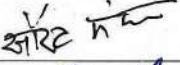
Date: 17.04.2026 (Friday)

Sl.	Name	Designation	Organisation	Contact No.	E-mail Id	Signature
46	Nitesh Nials	DGM(b)	NTPC Barch	9425281318	niteshnials@ntpc.co.in	
47	B S Ray	EE	ERPC			
48	A. Das	DD	ERP			
49	Sourav Mandal	CM(MO)	ER LDC	9402102354	souravmandal@gmail.com	
50	Sayantana Dutta	Senior Manager	NTPC Talcher Kanaha	9434069724	sayantandutta@ntpc.co.in	
51						
52						
53						
54						
55						
56						
57						
58						
59						
60						

Ref: C/PMD/ERES-44

Date: 13.04.2026

Shri K.B. Jagtap
Member Secretary
Eastern Regional Power Committee
14 Golf Club Road, Tollygunge
Kolkata-700033

Sub: Reconductoring of the lines of Chukha Transmission system under ERES-44 scheme-reg.

Dear Sir,

This has reference to ERPC letter No. ERPC/Operation/2026/2497 dated 26.03.2026 on the subject cited above.

In this regard, it is submitted that, considering the criticality of the scheme, NIT for reconductoring packages under ERES-44 were promptly floated in Jan'25. However, due to low participation in bids on account of required technology and various representations from prospective bidders regarding prior operational experience, the packages could not be awarded.

The matter has been further deliberated in the meeting held under the Chairmanship of Member (Power System), CEA on 09.04.2026, wherein it has been decided that re-tendering of the packages under the subject scheme is to be taken up after incorporating suitable relaxation in prior operational experience in the tender documents to encourage wider participation of the bidders.

POWERGRID remains fully committed to expediting the process and expeditious execution of the critical reconductoring works associated with the Chukha Transmission System.

Thanking you,

Yours sincerely,



(Akhilesh Pathak)

Executive Director

Project Management Dept.

AUFLS Status

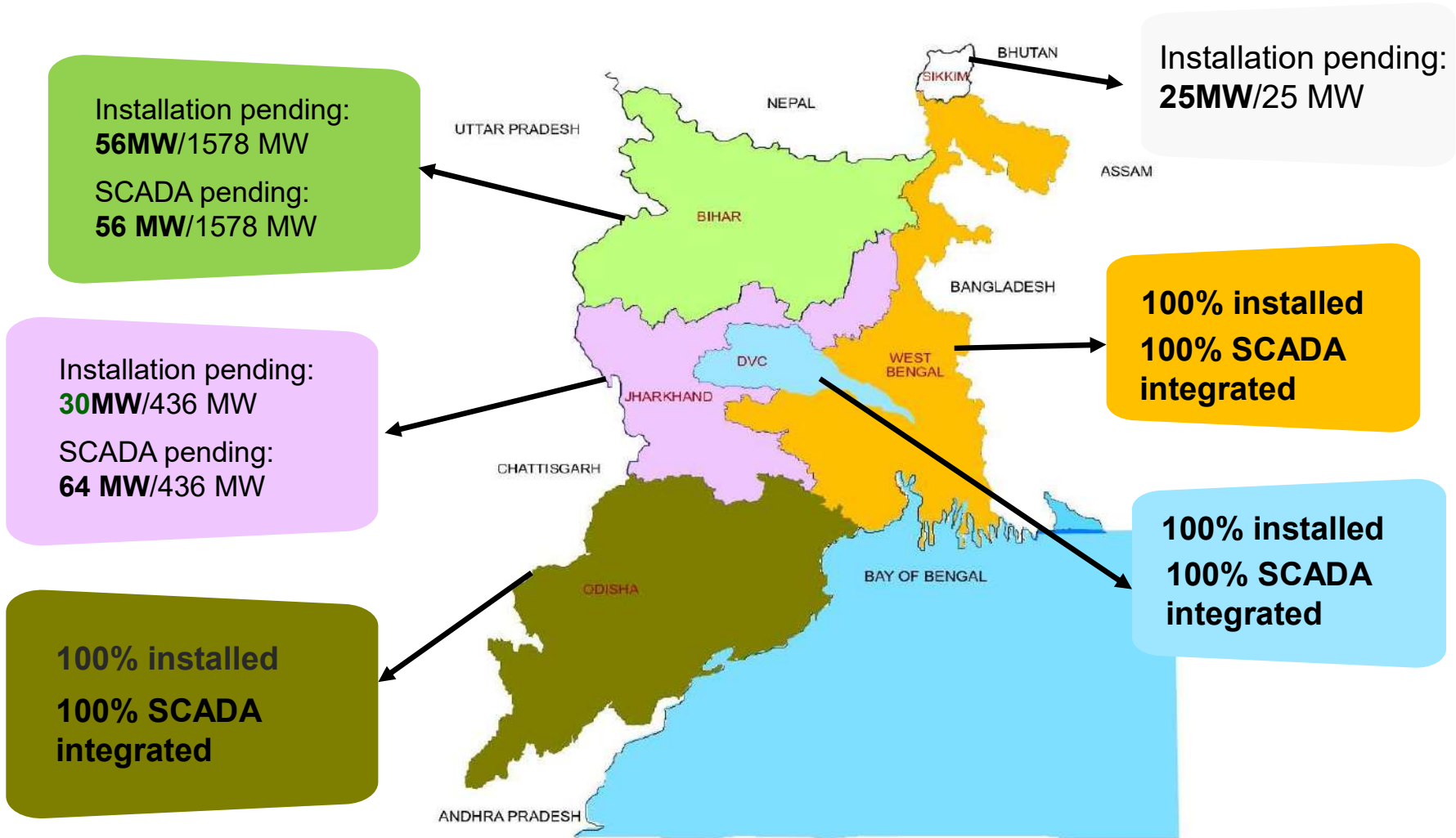

NKSTPS (3X660 MW)

Annex B.2.6



NORTH KARANPURA UNIT-2

Background & Context



NORTH KARANPURA

North Karanpura Unit-2 (660 MW) was facing high HP turbine shaft & pedestal vibration since Oct 2025. Vibration were increasing with load and duration, indicates progressive mechanical degradation.

Shaft vibrations were reaching up to **280 microns** all of a sudden and OEM recommends shutdown at 240 micron. More than **35** such spikes observed in January alone with cumulative duration of **6 hours**.

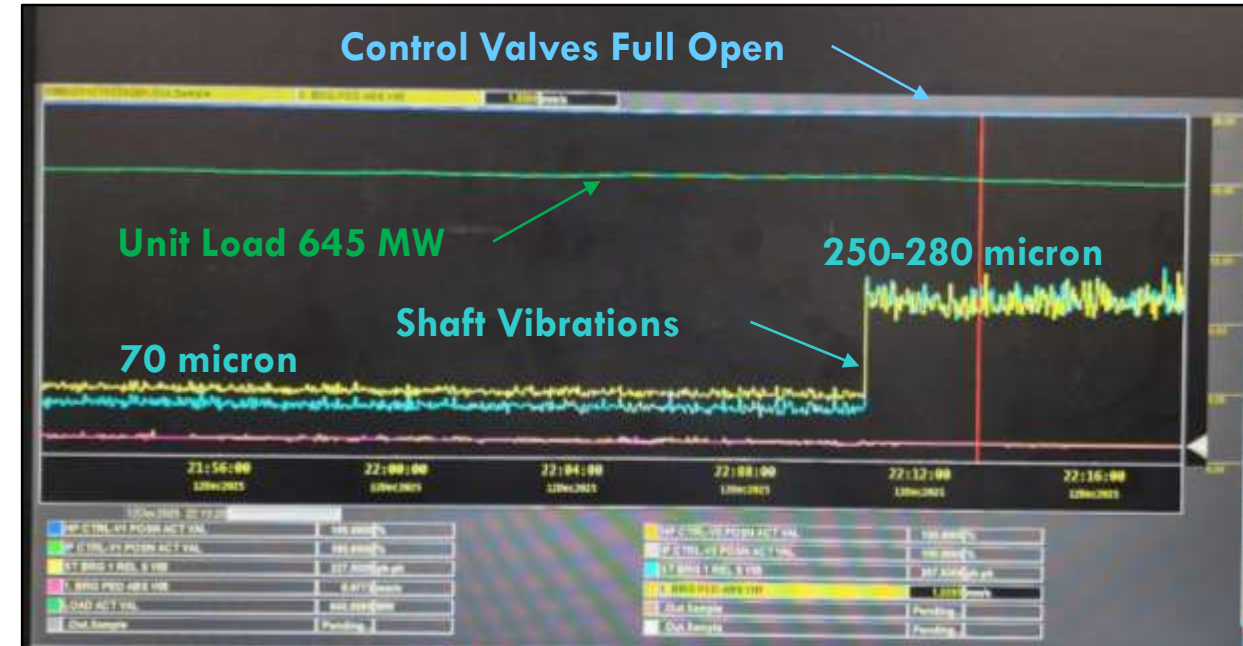

Sudden spike pattern in TG vibration at constant load and fixed control valves opening



Vibration Profile (OCT-2025)



NORTH KARANPURA

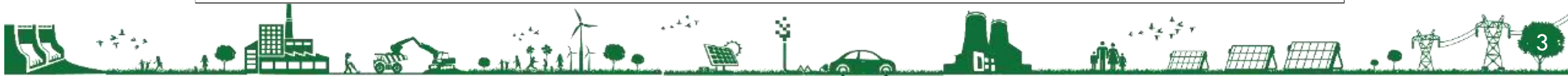
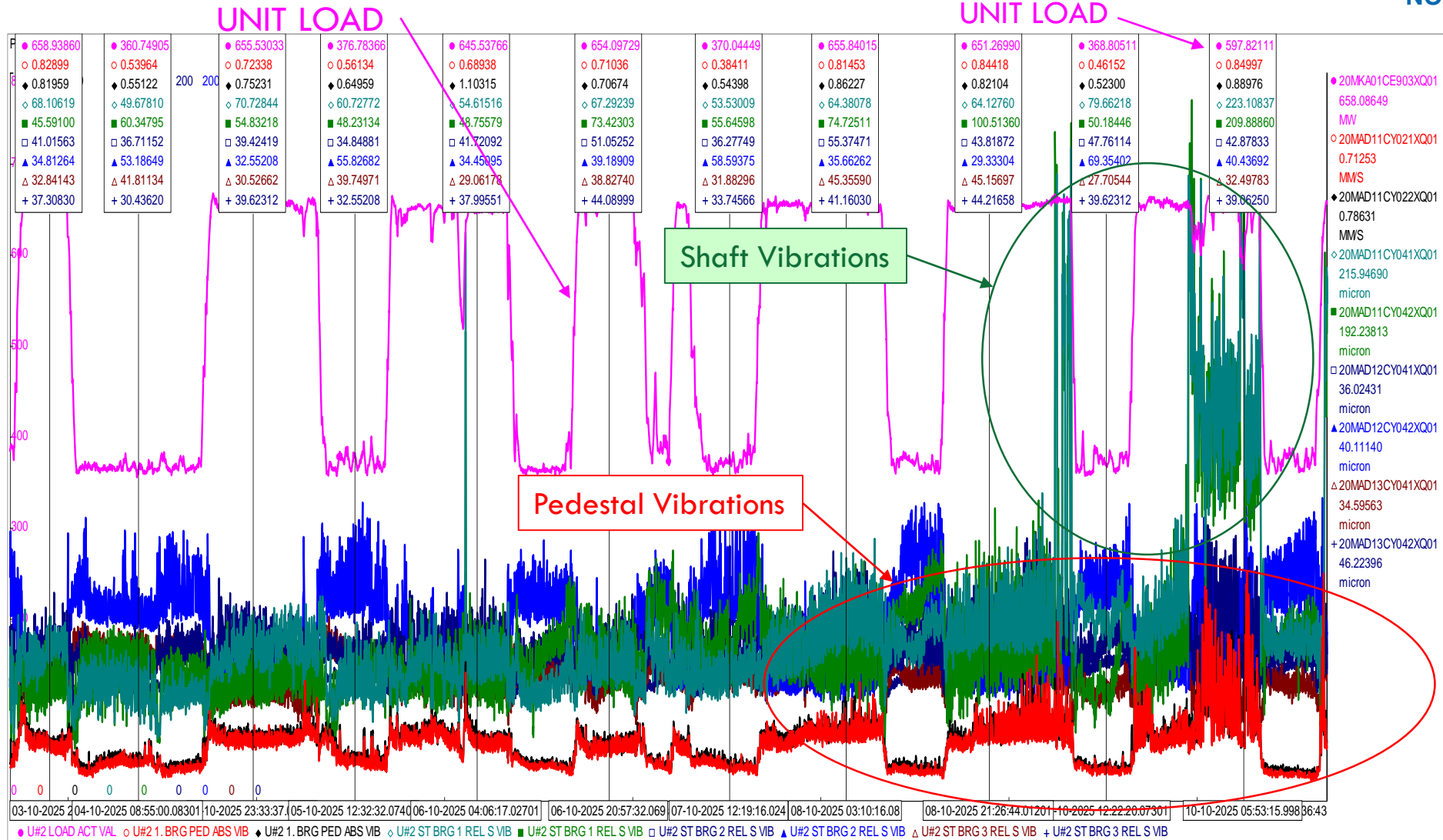

Vibration Profile (OCT-2025)



NORTH KARANPURA

UNIT LOAD

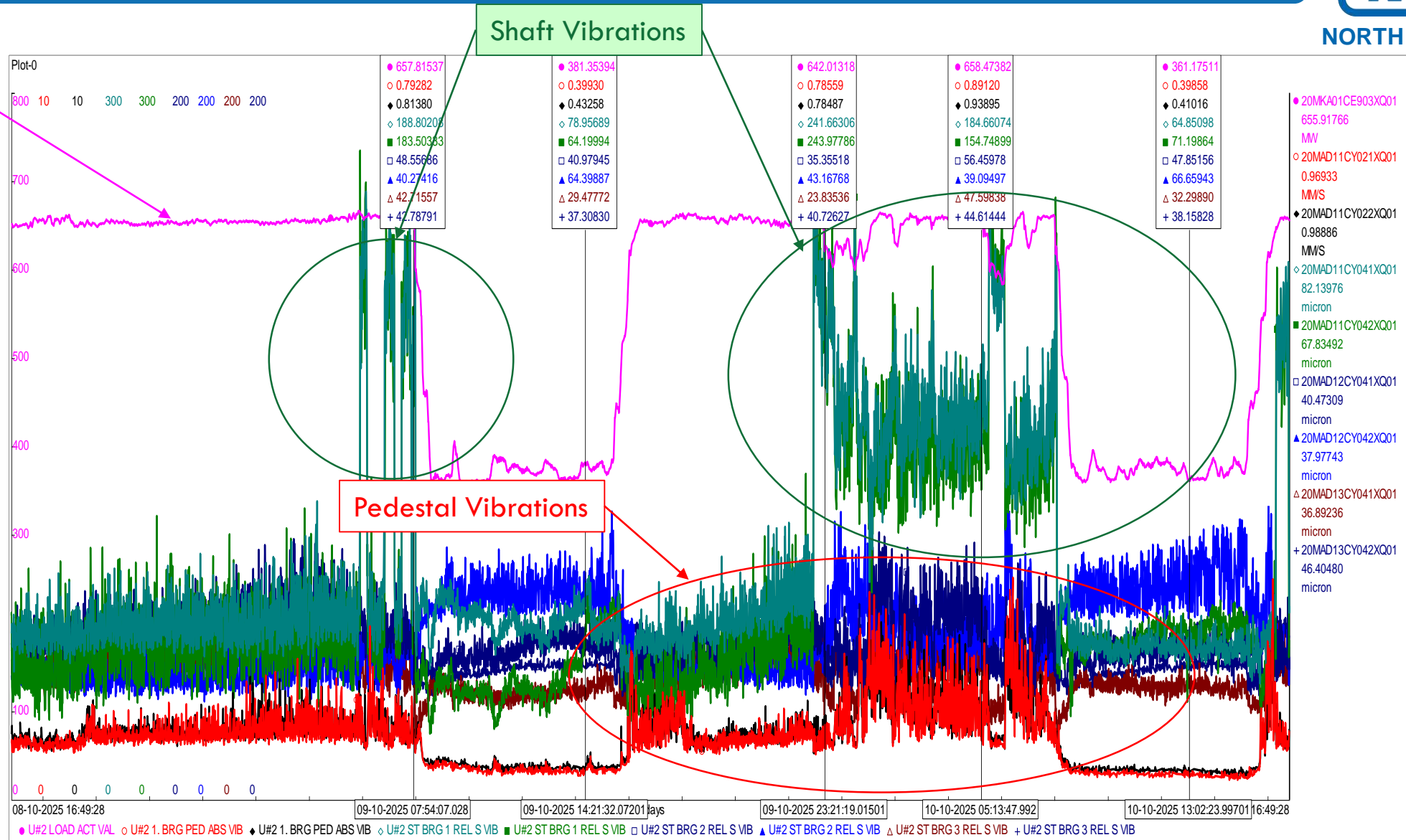

Performance Degradation Trend



NORTH KARANPURA

1. Declared Capacity reduced to ~ 497 MW in phases as vibration levels continued increasing
2. Cyclic fluctuations observed in shaft vibration and pedestal vibration and **axial shift** as well.
3. Stable operation became infeasible when vibration started increasing at MTL also.
4. Operational mitigation measures attempted.
 - Turbine valves at different position set
 - Overload valve closing
 - Lube oil temperature change
 - Steam parameters combination
 - HP Heaters isolation etc.

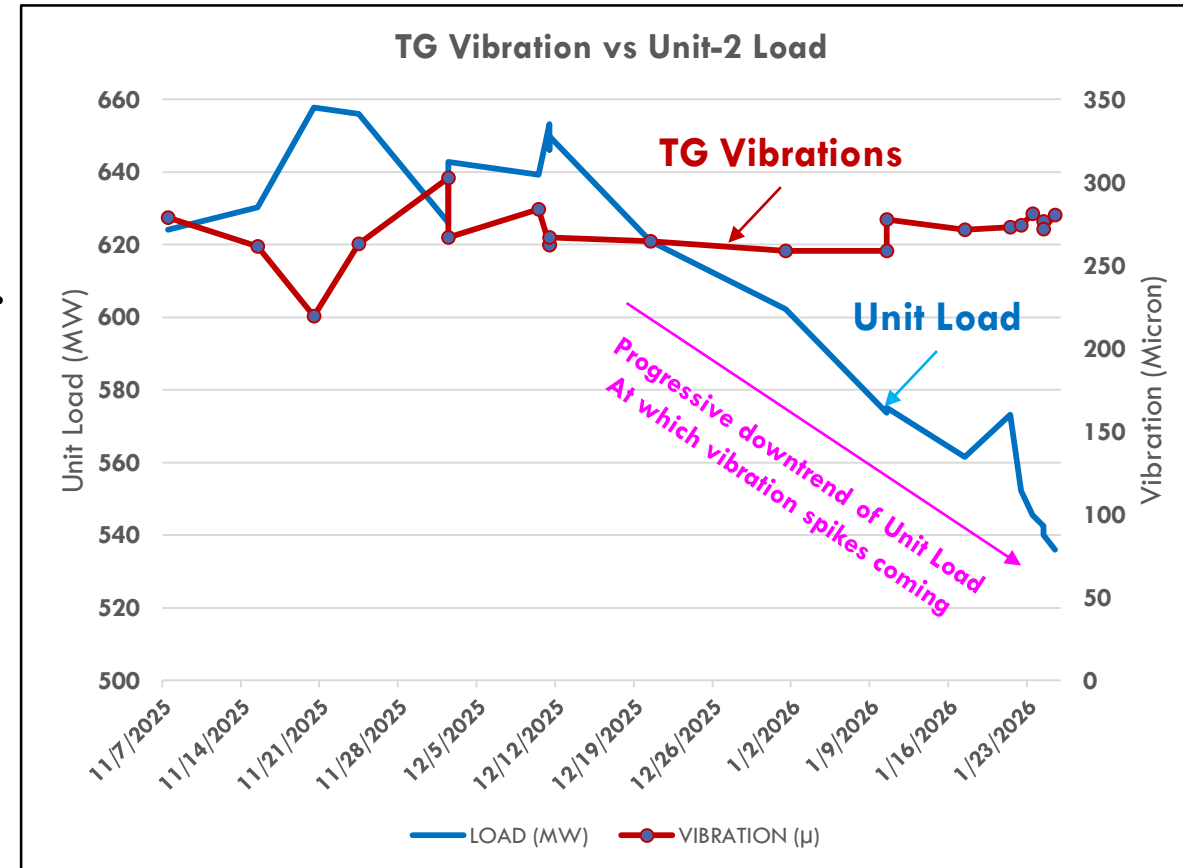

- The Shaft Vibrations levels were continued to deteriorate and cyclic fluctuations in pedestal & Shaft Vibrations were observed.
- The Deterioration reached a stage where stable operation was not feasible even at reduced load, indicating mechanical distress.
- On 24th March Abnormal Sound was heard from the Turbine area along with Vibrations.
- Unit was Stopped as a Precautionary measure to safeguard Man & Machine from serious damage.



TG Shaft and Pedestal Vibration Profile (24.3.26)



NORTH KARANPURA

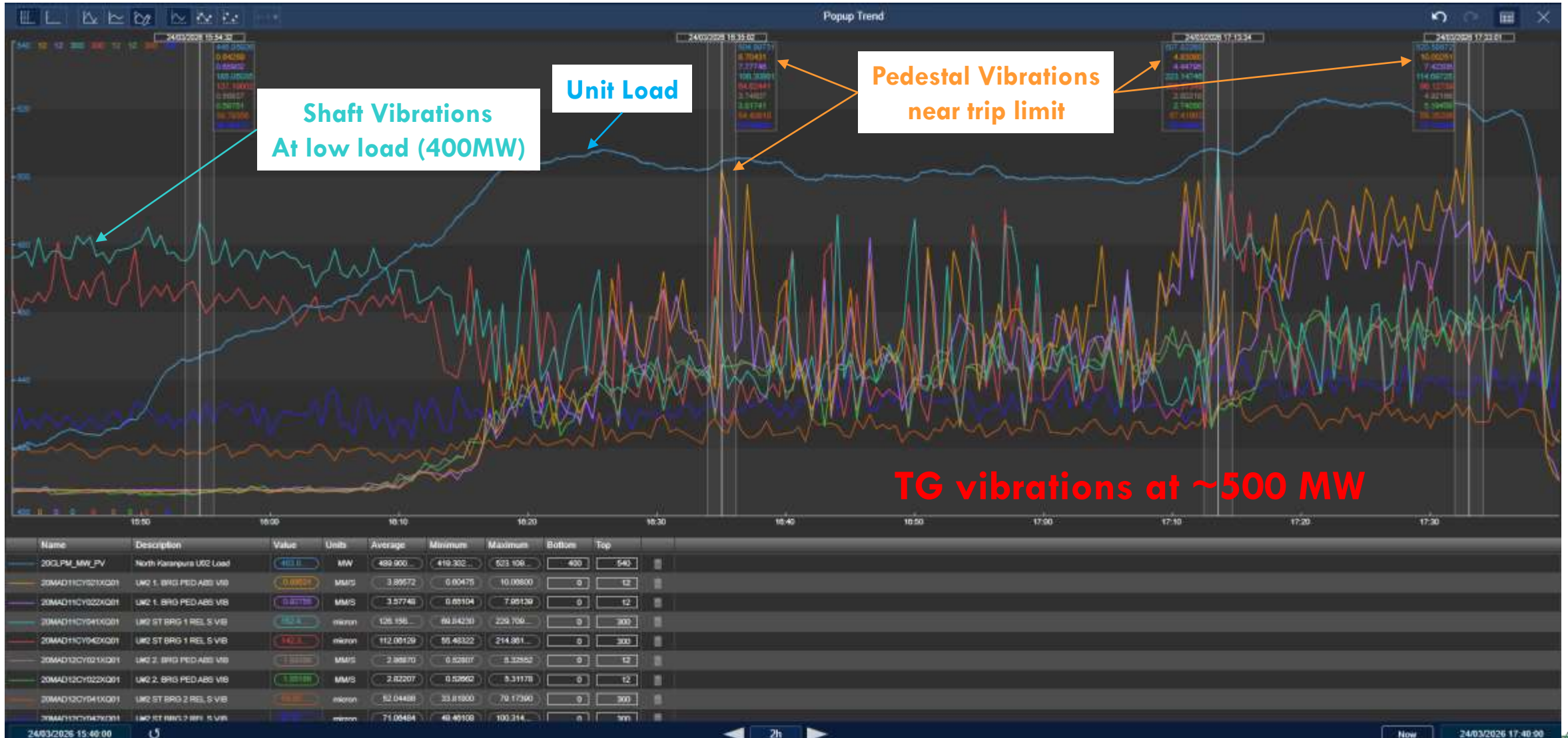

Major Technical Constraints : No # 2



NORTH KARANPURA

1. Unsafe Start-up due to lack of turbine stress evaluation

- Unavailable temperature measurement points (HP/IP/LP sections)
 - HPT 2/3 inner casing temperature points out (Feb 2026, 18-3-26)
 - IPT inner casing temperature all 3 points out (August 2024)
 - LPT last stage blading 2/3 temperature points out (2 March-2026)



Bharat Heavy Electricals Limited, HEEP, Haridwar
Steam Turbine Engineering

3rd September 2024

North Karanpura Steam Turbine Configuration

Steam Parameters :
MS Pr (ata): **260** MS Temp (°C): **593** HRH Temp (°C): **593** Vacuum : **196** mmHg(a)

Turbine Modules :
HP : H70 ; **IP** : 150 ; **LP** : NL2 x 5 (High Back Pressure). Air Cooled Condenser.
ESV : 2 x Ø 250 / 200 (Casing Mounted); **IV** : 2 x Ø 560 / 500 (Casing Mounted); & Overload Valve

Problem

It was reported on 14th August 2024 from 660 MW North Karanpura site that all the three thermocouples of IP Turbine failed in running condition. So stress monitoring of IP Shaft is not possible during startup and transient operation. In turbine automatic startup control (ATRS), IP shaft stresses cannot be monitored.

Replacement of thermocouples of IP Turbine which are installed in inner casing, requires long shutdown, cooling and opening of IP Turbine.

An intermediate solution for startup of the machine, in absence of IPT thermocouples has been formulated and described below.

Contingency Procedure by BHEL for turbine rolling
(For Short Duration)



Major Technical Constraints : No # 3



NORTH KARANPURA

LPT inlet compensator material failure → resulting in poor vacuum operating in the range of 200 to 250 mbar



Product Warning

Adjusted Requirements for Low Pressure Blading Inspection and Implementation of an Adjusted Condenser Back Pressure Limitation Curve

SB1-23-0091-ST-EN-02

Risk of Death and Serious Personal Injury

OBSERVATIONS IN THE FIELD REVEALED BLADE ROOT FINDINGS FOR SOME 50Hz UNITS WITH NL5m² La-0 BLADES. FURTHER OPERATION OF THE UNITS, WITHOUT IMPLEMENTING THE MITIGATION MEASURES DESCRIBED IN THIS PRODUCT WARNING, MAY RESULT IN AN ELEVATED RISK OF CRACK INITIATION AND PROPAGATION. IN A WORST-CASE A BLADE LIBERATION MAY OCCUR, CAUSING SERIOUS INJURIES OR DEATH TO PERSONNEL.

THIS PRODUCT WARNING STRONGLY RECOMMENDS FOLLOWING SIEMENS ENERGY INSPECTION INSTRUCTIONS AND TO IMPLEMENT AN ADJUSTED CONDENSER BACK PRESSURE LIMITATION CURVE WITH THE RELATED OPERATION INSTRUCTIONS AND LIMITATIONS GIVEN HEREAFTER IN THIS BULLETIN.

FAILURE TO FOLLOW THE RECOMMENDATIONS, INSTRUCTIONS AND ADVICE SET FORTH IN THIS PRODUCT WARNING MAY RESULT IN SERIOUS BODILY INJURY AND/OR DEATH, LOSS AND/OR DAMAGE TO THE PRODUCTS REFERENCED, EQUIPMENT OR OTHER PROPERTY.

Supersedes: SB1-20-5018-ST-EN-02
ALL RIGHTS RESERVED
Confidential Information

© Siemens Energy 2024

Publication Date: 2023-07-21
Page 4 of 5

and the back pressure. Rotating instabilities cause higher non-synchronous excitation of the last stage blade in a certain load range and will increase with higher backpressure levels.

A continuous operation of the last stage blades (see figure 1) at certain load points can cause elevated blade vibrations which results in an increased blade lifetime consumption. The risk of crack initiation therefore is also increased. Further operation without implementing / applying the mitigation measures described hereafter may result in a blade liberation and in serious bodily injury or death, and/or equipment and property damage.

Based on the continuous monitoring of our installed steam turbine fleet and the operating experience collected, Siemens Energy has defined a protection concept (e.g., condenser back pressure limitation curve, state of the art

- The last stage blades including the blade roots must be inspected after reaching 1.000 starts, 50.000 equivalent operating hours or 50 operating hours spent in the monitored part load range since commissioning or last inspection, whichever comes first. The monitored part load range comprises the "Transient Operation Only" and "Time Restricted Operating" zones per figure 2 and Appendix 1, figure 3.
- Time spent in the "Transient Operation Only" zone is reset after every last stage blade root inspection.
- Implementation of the adjusted condenser back pressure limitation curve, see Appendix 1, figure 3.
- Ensure the duration within the "Time



Product Warning by M/s Siemens



HPT Vibration issue was taken up with OEM (BHEL) and NTPC Turbine Expert Group. Their Observations and recommendations are as follows:-

❖ Observation & Recommendations :

1. Trend data indicates that the relative shaft vibration at Bearing 1 increased by approximately 100 microns (pk-pk) once the load exceeded 500 MW. However, only minimal variation was observed in the bearing vibration. During this rise in vibration, a positive shift in axial position was also recorded.
2. Variations in vibration levels were noted corresponding to changes in the OLCV position.
3. The trend analysis further shows that shaft vibration levels increased proportionally with load.
4. A correlation was observed between vibration levels and the positions of IPCV 1 and IPCV 2.
5. Although no significant change in shaft vibration amplitude was observed at the time of measurement, subharmonics were detected at Bearing 1 and super harmonics were identified at Bearing 4.
6. The vibration monitoring system should be inspected and verified for proper functioning. LP differential expansion value may be cross check.
7. Inspection of the IPCV and HPCV valves is recommended.
8. The HP module should be inspected, including performing a roll check and verifying rotor centering with respect to the casing.
9. Radial and axial keys should also be inspected.

Subhendu Kar

BHEL/ PSER/ TSX

BHEL

COS-TURBINE

Short term measures

1. By restricting opening of OLCV to 0% at higher load, bearing 1 shaft vibration fluctuations & amplitude is reduced by around 40-50 microns.
2. In case of further rise of vibration at bearing 1, Varying steam flow by taking HP heater out to see effect at full load on fluid instability can be tried out.
3. Varying seal steam pressure/Oil supply temperature to see effect on vibration at full load.
4. If vibration not reduced by above actions, bearing 1 & Bearing 2 inspections to be done.
5. Increasing loading of bearing no 1 for increasing damping & stiffness thus counter fluid instability.



Corporate Operation Services / Steam Turbine

Long term measures

1. HP inspection including Centring, roll check, bump check, HP gland centring.
2. Catenary & alignment checking for proper bearing loading.



1. Turbine Inspection (HP, IP, LP) : As per BHEL & Siemens recommendation
2. Rectification of mechanical deficiencies : As per BHEL recommendation
3. Restoration of temperature instrumentation (with OEM - BHEL) : To enable machine for safe start up, shut down, and Ramp up/down operation
4. Estimated completion: 01.05.2026
5. Observation so far:
 - a) Bearing-1 & 2 found damaged.
 - b) Metallic particle found in Turbine Oil, Other bearing inspection in progress for healthiness.
 - c) Shaft scratch at shaft bearing-1.
 - d) Further inspection including HPT boroscopy in progress.
 - e) Material failure of LPT Compensator, Replacement in progress





NORTH KARANPURA

THANK YOU

Annexure-B.2.7

Record Of Notes of Handholding session on Available

Options for Requisition Punching in WBES

ERLDC organized a handholding session for ER beneficiaries on 17th April 2026 at 15:00 hrs to demonstrate the available options for requisition punching in WBES in line with the suggestions of the OCC Forum. The session was aimed at facilitating a smooth transition from the existing default option of "Total Full Requisition" to "Full Surrender" for day-ahead requisition submission.

During the session, ERLDC briefed the participants on the need for this transition, highlighting the following key points:

- As per Clause 49(1)(f)(i) of the IEGC 2023, requisitions are required to be furnished by the concerned SLDC on behalf of intra-State drawee GNA grantees after publication of entitlement and within the specified timeline. Accordingly, submission of requisition is an active responsibility of the concerned SLDC, even in cases where the beneficiary intends to avail full entitlement.
- As per Clause 45(14) clause of the IEGC 2023, schedules under GNA are required to remain within the granted GNA limits. Under the existing default option of "Total Full Requisition", instances have been observed where requisitions exceed the GNA limit. Consequently, after closure of the requisition submission timeline [08:30 hrs of (D-1)], RLDC is required to curtail schedules on a pro-rata basis to keep GNA schedules within GNA limit. Such curtailment may lead to deviation from Merit Order Despatch principles of beneficiaries.

To support a smooth transition, ERLDC advised all beneficiaries to utilize the existing file upload feature in WBES for requisition submission, noting that the feature is already used by some beneficiaries, particularly to facilitate faster and more efficient submission of requisition in cases involving multiple ISGS generators. A live demonstration of the file upload feature was also conducted during the session for awareness. It was further indicated that system-generated email notifications will be sent to beneficiaries who have not submitted their requisition on (D-1), serving as a reminder.

During the interaction, West Bengal and Sikkim sought clarification regarding requisition punching for hydro generating stations. ERLDC clarified that there is no change in the existing practice: requisition punching is not required for ISGS (share allocation-based) hydro stations, while it remains applicable for IPP hydro plants as per the current procedure.

Bihar raised concerns regarding handling of network outages within the stipulated timeline for requisition submission. ERLDC clarified that such instances are rare and can generally be managed by switching to alternate internet service providers. In exceptional circumstances, ERLDC Control Room may also be informed for necessary assistance.

ERLDC reiterated that all beneficiaries should actively utilize the file upload feature in WBES in the days leading up to the implementation of the revised default option, to ensure familiarity with the process and enable a seamless transition.

Annex B.2.13

Proposed Modified Logic: Shown In Red Lines

Modified SPS 1000 Logic

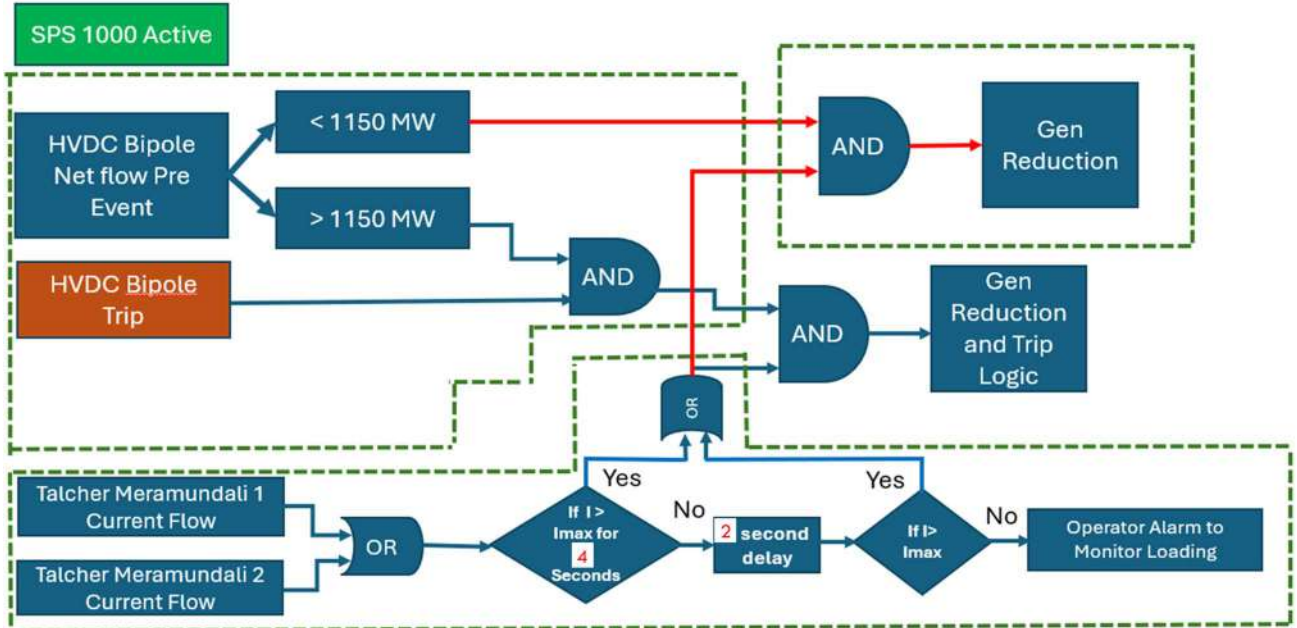

Modified SPS 1000 Logic

